

## Toshiba Air Conditioning - Estia Split Data Sheet

HWS-805H-E

Estia Split - Air-to-Water Heat Pump

### Features

- High energy efficiency providing enhanced energy savings
- Quick and easy to install
- Large screen remote controller - simple, intuitive and easy to use
- Best in class performances



### Physical Data - Outdoor Unit

Outdoor unit		HWS-805H-E
Hydro unit combination		HWS-805XWHM3-E/HWS-805WHT6-E/HWS-805WHT9-E
Dimensions (H x W x D)	mm	890 x 900 x 320
Weight	kg	63
Sound pressure level (max.)	dB(A)	49
Sound power level (max.)	dB(A)	64
Sound pressure level (night mode)	dB(A)	TBC
Sound power level (night mode)	dB(A)	TBC
Compressor type		DC twin rotary
Refrigerant		R410A
Flare connections (gas-liquid)	inch	5/8-3/8
Minimum pipe length	m	5
Maximum pipe length	m	30
Maximum height difference	m	30
Chargeless pipe length	m	30
Operating range in space heating*	°C	-20-25
Operating range domestic hot water	°C	-20-43
Operating range in cooling	°C	10-43
Power supply	V-ph-Hz	220/230-1-50

\* Depending on the conditions only back-up heater operates.

\*\* Heater operation in more than 35°C

### Dimensional Drawings

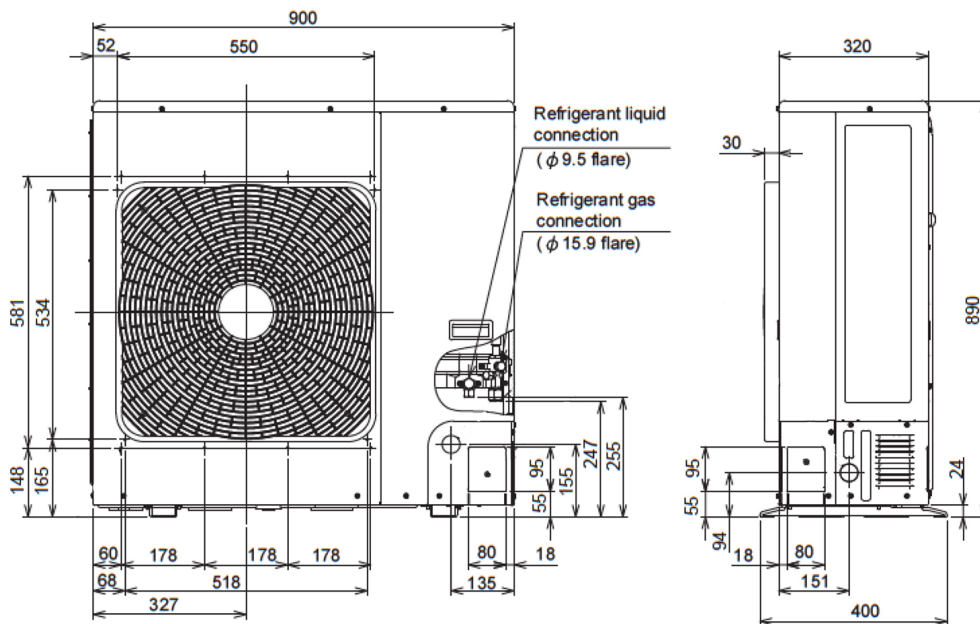

Cool Designs Ltd

Raising the Standards in Air Conditioning Distribution

www.cdlweb.info

