



*Pocket Handbook
Of Technical Data
For the **TOSHIBA**
Range of Products*



The equipment listed within this publication are designed for R32 Refrigerant.

R32 refrigerant is a “Mildly Flammable” refrigerant and is categories as being an A2L refrigerant.

Toshiba Indoor units designed for R32 can be coupled to suitable Toshiba R32 or R410A outdoor units, R410A indoor units **CANNOT BE CONNECTED TO R32** outdoor units.

Provide mechanical protection for all installed pipe work, keep joints to a minimum, flare connections at the outdoor unit is acceptable, it is also acceptable to make the final joint at the indoor unit via a flare connection, additional joints within the building should be of a braze type connection.

When working with R32, make sure the area is well vented, if the equipment is located in a basement area, or a below ground floor “Well area”, utilise additional means of ventilation.

Extract from RAV-GP range installation manual.

Since R32 is heavier than air, it tends to accumulate at the bottom (near the floor).
Ventilate properly for the working environment to prevent its combustion.
Especially in a basement or a closed room where is the high risk of the accumulation, ventilate the room with a local exhaust ventilation.
If refrigerant leakage is confirmed in the room or the place where the ventilation is insufficient, do not work until the proper ventilation is performed and the work environment is improved.

The equipment listed is designed to be installed by a qualified f-gas registered engineer.

It is strongly recommended that the installing engineer reads the installation manual provided with the equipment, before proceeding.

Extract from RAV-GP range installation manual.

- Appliance and pipe-work shall be installed, operated and stored in a room with a floor area larger than A_{\min} m².
How to get A_{\min} m² : $A_{\min} = (M / (2.5 \times 0.22759 \times h_0))^2$
M is the refrigerant charge amount in appliance in kg. h_0 is the installation height of the appliance in m: 0.6 m for floor standing/1.8 m for wall mounted/1.0 m for window mounted/2.2 m for ceiling mounted (For these units recommend installation height 2.5 m.).

Index

Page

Mechanical Specification RAS R32	4
Performance & Electrical Specification RAS R32 Single Splits	5
Performance & Electrical Specification RAS R32 Multi Splits	5
Acoustic Data RAS Outdoor Units	6
Acoustic Data RAS Indoor Units	6
RAS Multi-Split Combination Examples	7
RAS Auto Restart	8
RAS Fault codes	9
Mechanical Specification RAV DI/SDI R32	10
Performance & Electrical Specification RAV DI/SDI R32 Single Splits	10
Performance & Electrical Specification RAV DI/SDI R32 Multi Splits	11
Acoustic Data RAV DI/SDI Indoor Units	11
Acoustic Data RAV DI/SDI Outdoor Units	11
Replacement Technology	12
Refrigerant Replacement	13
R32 Quantity in Occupied Spaces	14
RAV DI/SDI Twin Split	15
RAV DI/SDI Triple Split	17
RAV DI/SDI Quad Split	19
RAV DI/SDI Multi Split Wiring	20
Common Sensor Characteristics	21
RAV###KRT Indoor Trouble Shooting	22
RAV Indoor units Lamp Indication	24
Fault Codes All Commercial & VRF Systems	28
TCC-Net Central Controller Error Detection	42
"Black Pear" Error Code Cross Reference	42
TCC Link Local Hard-Wired Controller Guidelines	44
System Configuration Menu	45
Optional Control Accessories	48
TCC-Net Control	50
DI/SDI/VRF Control Configuration	53
RAV DI/SDI Data Retrieval Guide	54
RAV DI/SDI Network Addressing	55
RAV DI/SDI Integration with AI System	98
RAV DI/SDI Temperature Sensing	59
Notes	60
Additional Publications	61
Contact Details	62

Mechanical Specifications - RAS R32 Outdoor Units

Model	Pipe Sizes (")		Min/Max Pipe Sep (m)	Max Height Separation (+/-) (m)	Pre-Charge (m)	Add Charge (g/m)	Base Charge (kg)	Dimensions (mm)	Weight (kg)			
	Liquid	Suction										
RAS Outdoor Units												
RAS-05BAVG-E	1/4	3/8	2/15	12	15	N/A	0.40	530x660x240	21			
RAS-07BAVG-E							0.40					
RAS-10BAVG-E1							0.43					
RAS-13BAVG-E1							0.43					
RAS-16BAVG-E		1/2	2/20			2/20	20	0.80	550x780x290	34		
RAS-18BAVG-E								0.88				
RAS-24BAVG-E								1.08				
RAS-05J2AVG-E		3/8	2/15			2/15	15	N/A	0.40	530x660x240	22	
RAS-07J2AVG-E									0.43			
RAS-10J2AVG-E									0.46			
RAS-13J2AVG-E			1/2			2/20		2/20	20	0.62	550x780x290	30
RAS-16J2AVG-E										0.88		
RAS-18J2AVG-E										1.08		
RAS-24J2AVG-E		3/8	2/20			2/20	15	20	0.51	550x780x290	28	
RAS-10PAVSG-E	0.67											
RAS-13PAVSG-E	1/2	2/20	2/20	15	20	0.8	550x780x290	34				
RAS-16PAVSG-E						1.1						
RAS-18PAVSG-E	3/8	2/25	2/25	10	N/A	1.14	630x800x300	43				
RAS-22PAVSG-E						1.0						
RAS-24PAVSG-E	1/2	2/25	2/25	10	20	N/A	0.85	630x800x300	38			
RAS-10PAVPG-E	3/8	2/30*	2/30*	10	30	N/A	1.02					
RAS-13PAVPG-E	3/8x2	2/30*	2/30*	10	50	N/A	1.05					
RAS-16PAVPG-E	3/8x2+1/2x1	2/50*	2/50*	10	50	N/A	1.05					
RAS-2M10U2AVG-E	3/8x1+1/2x2	3/70*	3/70*	15	40	20	1.92			890x900x320	72	
RAS-2M14U2AVG-E	3/8x2+1/2x2	3/80*	3/80*	15	40	20	2.39					
RAS-2M18U2AVG-E	3/8x3+1/2x2	3/80*	3/80*	15	40	20	2.39					

*RAS Multi Pipe Configuration			
Model	Minimum Leg Length (m)	Maximum Leg Length (m)	Accumulative Liquid Line Length (m) (Legs A+B+C+D+E)
RAS-2M10U2AVG-E	2	15	20
RAS-2M14U2AVG-E	2	20	30
RAS-2M18U2AVG-E	2	20	30
RAS-3M18U2AVG-E	2	25	50
RAS-3M26U2AVG-E	3	25	70
RAS-4M27U2AVG-E	3	25	70
RAS-5M34U2AVG-E	3	25	80

Minimum quantity of Indoors = 2

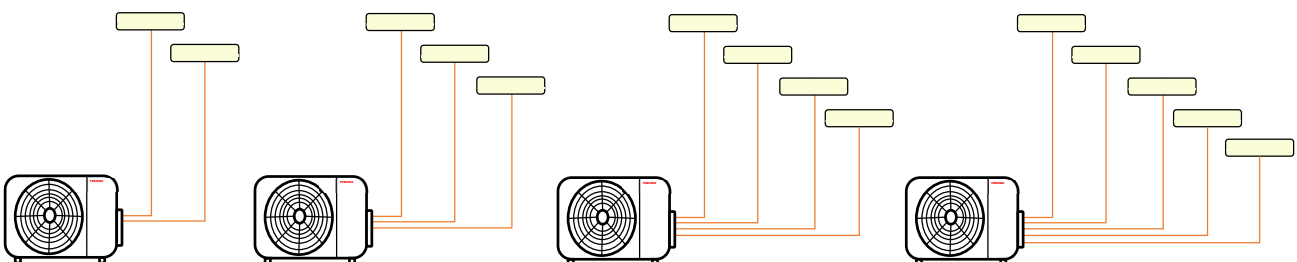

Performance & Electrical Specifications - RAS R32 Single Splits

Model	Capacity (kW)		Energy Rating Cool/Heat	Phase	Power To	Soft Start	Max. Running Current (A)	Suggested Fuse Size (A) #	Interconnect Cable
	Cool	Heat							
RAS Split Systems									
RAS-05BAVG-E	1.5	2.0	A+/A+	1Ph + N	Indoor/ Outdoor	Yes	2.40	10	3C+ E
RAS-07BAVG-E	2.0	2.5	A+/A+				3.25	10	
RAS-10BAVG-E1	2.5	3.2	A+/A+				4.20	10	
RAS-13BAVG-E1	3.3	3.6	A+/A+				5.50	10	
RAS-16BAVG-E	4.6	5.4	A++/A+				7.19	16	
RAS-18BAVG-E	5.0	5.4	A++/A+				7.50	16	
RAS-24BAVG-E	6.5	7.0	A++/A+				10.55	16	
RAS-05J2AVG-E	1.5	2.0	A++/A+				2.40	10	
RAS-07J2AVG-E	2.0	2.5	A++/A+				3.25	10	
RAS-10J2AVG-E	2.5	3.2	A++/A+				4.20	10	
RAS-13J2AVG-E	3.3	3.6	A++/A+				5.50	10	
RAS-16J2AVG-E	4.2	5.0	A++/A+				7.19	16	
RAS-18J2AVG-E	5.0	5.4	A++/A+				7.5	16	
RAS-24J2AVG-E	6.5	7.0	A++/A+				10.55	16	
RAS-10PAVSG-E	2.5	3.2	A++/A++				3.97	10	
RAS-13PAVSG-E	3.5	4.2	A++/A++				5.22	10	
RAS-16PAVSG-E	4.6	5.5	A++/A+				7.10	16	
RAS-18PAVSG-E	5.0	6.0	A++/A+				8.05	16	
RAS-22PAVSG-E	6.1	7.0	A++/A+				9.30	16	
RAS-24PAVSG-E	7.0	8.0	A++/A+				11.30	16	
RAS-10PAVPG-E	2.5	3.2	A+++/A+++	3.40	10				
RAS-13PAVPG-E	3.5	4.0	A+++/A+++	4.01	10				
RAS-16PAVPG-E	4.5	4.5	A+++/A+++	6.44	16				
Ambient Range; Cooling -15°C to +46°C, Heating -15°C to +24°C									

Suggested fuse sizes are for guidance only, the electrical installation must be completed in-line with current electrical regulations, BS 7671:2018+A1, 2020 – 18th Edition, IET.

Performance & Electrical Specifications - RAS R32 Multi Splits

Model	Min-Max Indoors	Capacity (kW)		Energy Rating Cool/Heat	Phase	Power To	Soft Start	Max. Running Current (A)	Suggested Fuse Size (A) #	Interconnect Cable
		Cool	Heat							
RAS Multi Systems										
RAS-2M10U2AVG-E	2 – 2	1.0 – 3.9	1.0 – 4.9	A++/A++	1Ph + N	Outdoor	Yes	4.17	10	3C + E
RAS-2M14U2AVG-E	2 – 2	1.6 – 4.9	1.3 – 5.2	A++/A++				4.87	10	
RAS-2M18U2AVG-E	2 – 2	1.7 – 6.2	1.3 – 7.5	A++/A++				6.96	16	
RAS-3M18U2AVG-E	2 – 3	2.4 – 6.5	1.9 – 8.0	A++/A++				8.79	16	
RAS-3M26U2AVG-E	2 – 3	4.1 – 9.0	2.0 – 11.2	A++/A++				11.67	16	
RAS-4M27U2AVG-E	2 – 4	4.2 – 9.3	2.9 – 11.7	A++/A++				13.09	20	
RAS-5M34U2AVG-E	2 – 5	3.7 – 11.0	2.7 – 14.0	A++/A+				13.64	20	
Ambient Range; Cooling -10°C to +46°C, Heating -20°C to +24°C										

Suggested fuse sizes are for guidance only, the electrical installation must be completed in-line with current electrical regulations, BS 7671:2018+A1, 2020 – 18th Edition, IET.

Acoustic Data – RAS Outdoor / Indoor Units

RAS Outdoor Units			
Model	Cool dB(A)		Heat dB(A)
RAS-05BAVG-E	48		50
RAS-07BAVG-E	48		50
RAS-10BAVG-E1	49		51
RAS-13BAVG-E1	50		51
RAS-16BAVG-E1	50		52
RAS-18BAVG-E1	50		52
RAS-24BAVG-E1	55		55
RAS-05J2AVG-E	46		48
RAS-07J2AVG-E	46		48
RAS-10J2AVG-E	48		50
RAS-13J2AVG-E	48		50
RAS-16J2AVG-E	49		51
RAS-18J2AVG-E	50		52
RAS-24J2AVG-E	55		55
RAS-10PAVSG-E	46		47
RAS-13PAVSG-E	48		50
RAS-16PAVSG-E	49		52
RAS-18PAVSG-E	49		52
RAS-22PAVSG-E	53		52
RAS-24PAVSG-E	53		53
RAS-10PAVPG-E	46		47
RAS-13PAVPG-E	48		50
RAS-16PAVPG-E	49		50
RAS-2M10U2AVG-E	45		46
RAS-2M14U2AVG-E	45		46
RAS-2M18U2AVG-E	47		50
RAS-3M18U2AVG-E	47		50
RAS-3M26U2AVG-E	47		49
RAS-4M27U2AVG-E	47		49
RAS-5M34U2AVG-E	51		55
Note: Sound measured in Pressure dB(A)			

RAS Indoor Units			
Model	High dB(A)	Med dB(A)	Low dB(A)
RAS-B05BKVG-E	37	-	22
RAS-B07BKVG-E	38	-	23
RAS-B10BKVG-E	39	-	24
RAS-B13BKVG-E	42	-	24
RAS-B16BKVG-E	43	-	25
RAS-B18BKVG-E	48	-	32
RAS-B24BKVG-E	48	-	35
RAS-B05J2KVG-E	37	-	19
RAS-B07J2KVG-E	38	-	20
RAS-B10J2KVG-E	39	-	21
RAS-B13J2KVG-E	42	-	21
RAS-B16J2AVG-E	43	-	22
RAS-B18J2KVG-E	48	-	32
RAS-BJ2KVG-E	48	-	32
RAS-B10PKVSG-E	39	-	24
RAS-B13PKVSG-E	39	-	24
RAS-B16PKVSG-E	43	-	26
RAS-B18PKVSG-E	44	-	31
RAS-B22PKVSG-E	46	-	34
RAS-B24PKVSG-E	48	-	35
RAS-B10U2FVG-E	39	-	26
RAS-B13U2FVG-E	40	-	27
RAS-B18U2FVG-E	60	-	34
RAS-B10J2FVG-E	39	-	26
RAS-B13J2FVG-E	40	-	27
RAS-B18J2FVG-E	47	-	34
RAS-B10PKVPG-E	44	-	20
RAS-B13PKVPG-E	45	-	20
RAS-B16PKVPG-E	46	-	22
RAS-M10U2MUVG-E	37	-	30
RAS-M13U2MUVG-E	38	-	30
RAS-M16U2MUVG-E	40	-	31
RAS-M07U2DVG-E	35	-	27
RAS-M10U2DVG-E	35	-	27
RAS-M13U2DVG-E	37	-	27
RAS-M16U2DVG-E	35	-	25
RAS-M22U2DVG-E	38	-	32
RAS-M24U2DVG-E	39	-	33
Note: Sound measured in Pressure dB(A)			

RAS Multi-Split System Combination Examples

Outdoor Unit	Indoor Unit Size & Duty				
	Unit 1	Unit 2	Unit 3	Unit 4	Unit 5
RAS-2M10U2AVG-E 4.0 kW	05 (2.0kw)	05 (2.0kw)			
	07 (2.3kw)	05 (1.7kw)			
	10 (2.67kw)	05 (1.33kw)			
	07 (2.0kw)	07 (2.0kw)			
	10 (2.39kw)	07 (1.61kw)			
	10 (2.0kw)	10 (2.0kw)			
RAS-2M14U2AVG-E 4.4 kW	05 (2.0kw)	05 (2.0kw)			
	07 (2.7kw)	05 (2.0kw)			
	10 (3.73kw)	05 (1.87kw)			
	13 (4.0kw)	05 (1.6kw)			
	07 (2.7kw)	07 (2.7kw)			
	10 (3.34kw)	07 (2.26kw)			
	13 (3.64kw)	07 (1.96kw)			
	10 (2.8kw)	10 (2.8kw)			
	13 (2.3kw)	10 (2.1kw)			
	13 (2.2kw)	13 (2.2kw)			
RAS-3M18U2AVG-E 6.8 kW	05 (2.0KW)	05 (2.0KW)			
	07 (2.7KW)	05 (2.0KW)			
	10 (4.0KW)	05 (2.0KW)			
	13 (4.86KW)	05 (1.94KW)			
	16 (4.99KW)	05 (1.81KW)			
	07 (2.7KW)	07 (2.7KW)			
	10 (3.94KW)	07 (2.76KW)			
	13 (4.42KW)	07 (2.95KW)			
	16 (4.73KW)	07 (2.07KW)			
	10 (3.4KW)	10 (3.4KW)			
	13 (3.84KW)	10 (2.96KW)			
	16 (4.18KW)	10 (2.62KW)			
	13 (3.4KW)	13 (3.4KW)			
	16 (3.75KW)	13 (3.05KW)			
	16 (3.4KW)	16 (3.4KW)			
	05 (2.0kw)	05 (2.0kw)	05 (2.0kw)		
	07 (2.7kw)	05 (2.0kw)	05 (2.0kw)		
	10 (3.4kw)	05 (1.7kw)	05 (1.7kw)		
	13 (3.78kw)	05 (1.51kw)	05 (1.51kw)		
	16 (3.94kw)	05 (1.43kw)	05 (1.43kw)		
	07 (2.48kw)	07 (2.48kw)	05 (1.84kw)		
	10 (3.13kw)	07 (2.11kw)	05 (1.56kw)		
	13 (3.51kw)	07 (1.89kw)	05 (1.40kw)		
	16 (3.67kw)	07 (1.80kw)	07 (1.33kw)		
	10 (2.72kw)	10 (2.72kw)	05 (1.36kw)		
	13 (3.09kw)	10 (2.47kw)	05 (1.24kw)		
	16 (3.25kw)	10 (2.37kw)	05 (1.81kw)		
	13 (2.83kw)	13 (2.83kw)	05 (1.13kw)		
16 (2.99kw)	13 (2.72kw)	05 (1.09kw)			
07 (2.26kw)	07 (2.27kw)	07 (2.27kw)			
10 (2.84kw)	07 (1.98kw)	07 (1.98kw)			
13 (3.26kw)	07 (1.76kw)	07 (1.76kw)			
16 (3.64kw)	07 (1.59kw)	07 (1.59kw)			

Above duty's (kw) are in the heating mode.

The above is an example only, for full combination tables covering up to 5 indoor units to 1 outdoor, please contact Cool Designs Technical Support.

RAS – Auto Restart Function

The indoor unit is equipped with an automatic restart facility that allows the unit to restart, at the last set operating conditions, after a power failure. The operation will resume without warning three minutes after power is restored.

This feature is not set up when these systems are shipped from the factory, therefore it will need to be activated by the installing company.

Generally, the process is the same for all RAS products since approx. 2001 and is as follows:

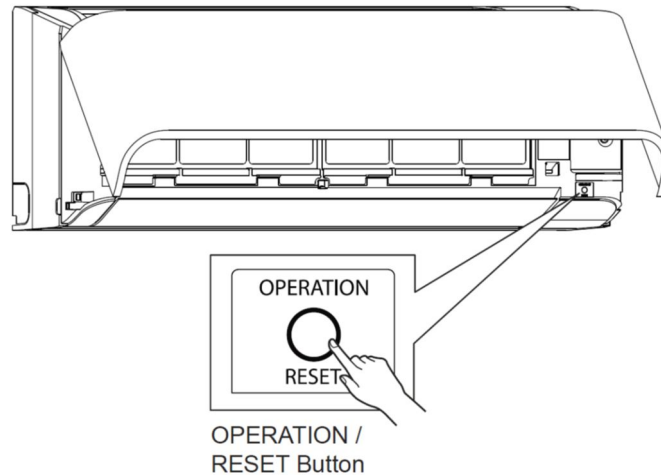

To initiate auto restart:

1. Turn the power on. Green/White, On/Off light will flash.
2. Set the system to operate using the remote controller. Green/White On/Off light will be on constantly.
3. Press and hold down the Operation/Reset button for more than three seconds. (Less than 10 Seconds.)
4. The indoor unit will beep three times to acknowledge set up. In most cases the green light changes to orange.
5. The system will continue to operate during this set up.
6. After set up the system may be stopped using the remote controller.

To cancel auto restart:

1. The system is operating. Green/White, On/Off light will be on constantly.
2. Stop the system operating using the remote controller. Green/White On/Off light will extinguish.
3. Press and hold down the operation / reset button for three seconds.
4. The indoor unit will beep three times to acknowledge cancellation.
5. The system will have stopped operating.

This feature cannot be set if the timer is in operation.

The louver will not swing, if it was previously set, when the system auto restarts.

Fault Codes – RAS Series

Do Not turn off the power supply before reading the fault codes, doing so will clear the diagnostic memory. Caution must be taken when removing the access covers as high voltages are present.

Fault codes are displayed through the LEDs flashing at 5 times per second. Note, the green LED will flash once per second when the system is initially powered.

More specific codes may be obtained, while in the fault mode through the wireless controller

1. Press **CHK** (12) to enter service mode.
2. Navigate through **TEMP ▲▼** buttons until all LEDs flash (From 1 to 33), accompanied by the internal buzzer – compare the displayed code with the table below.
3. Press **CLEAR** button to clear the existing fault code (controller displays 7F)
4. Press **ON/OFF** button to exit service mode.

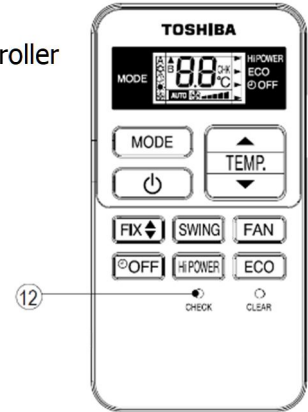

Block distinction		Operation of diagnostic function			
Check Code	Block	Check code	Cause of Operation	Air Conditioner status	Display flashing error
00	Indoor PCB	0C	TA Sensor open or short circuit or indoor PCB	Operation continues	Flashes when error is detected
		0d	TC Sensor open or short circuit or indoor PCB		
		11	Indoor fan motor or PCB	All OFF	
		12	Indoor PCB	Depend on cause of failure.	
01	Serial signal and connecting cable	04	Indoor to outdoor communication error, (includes compressor thermostat).	Indoor unit operates, outdoor unit stops.	Flashes when error is detected.
02	Outdoor PCB	14	Over current on inverter circuit, Inverter PCB or Compressor.	All OFF	Flashes after error is detected 8 times.
		16	Compressor position detection error or short circuit of compressor windings.	All OFF	
		17	Current detection circuit of inverter PCB error.	All OFF	Flashes after error is detected 4 times.
		18	TE or TS sensor open or short circuit or outdoor PCB.	All OFF	
		19	TD sensor open or short circuit or outdoor PCB.	All OFF	
		1A	Outdoor fan error or PCB	All OFF	Flashes after error is detected 8 times.
		1b	TO sensor open or short circuit or outdoor PCB.	Operation continues.	Record error after detected 4 times but does not flash display.
		1C	Compressor drive circuit, voltage, current, frequency abnormal.	All OFF	Flashes after error is detected 8 times.
03	"Others" including compressor	07	Indoor to outdoor communication error, Indoor/outdoor PCB, interconnecting cable, compressor thermostat	Indoor unit operates, outdoor unit stop	Flash when error detected.
		1d	Compressor does not rotate, lost phase, neutral, wiring.	All OFF	Flash after error is detected 8 times.
		1E	Discharge temperature exceeds 117°C	All OFF	Flashes after error is detected 4 times.
		1F	Compressor high current, power supply, compressor, Inverter PCB	All OFF	Flash after error is detected 8 times.
		21	Return signal of outdoor unit lost, power, indoor/outdoor PCB, high temperature on TE, TC.	Indoor unit operates outdoor unit stops	Flashes when error is detected 11 times.

Mechanical Specifications - DI / SDI R32 Single Splits

Model	Pipe Sizes		Min/Max Pipe Sep. (m)	Max height separation (+/-) (m)	Pre-Charge (m)	Add charge (g/m)	Base charge (kg)	Dimensions (mm)	Weight (kg)		
	Liquid	Suction									
Commercial Range											
RAV-GM301ATP-E	1/4	3/8	2/20	10	15	20	0.63	550X780X290	29		
RAV-GM401ATP-E		1/2					0.9		34		
RAV-GM561ATP-E		3/8	5/8		5/30		20		35	1.3	630x800x300
RAV-GM801ATP-E	5/50			30	35	2.1		890X900X320		42	
RAV-GM901ATP-E						5/60	80	5.0	2.4	1340x900x320	47
RAV-GM1101AT(8)P-E									1/2	1 1/8	5/60
RAV-GM1401AT(8)P-E	3/50			30	35	2.6	1550x1010x370	142			
RAV-GM1601AT(8)P-E	1/4	1/2	3/75						30	35	2.6
RAV-GM2241AT8-E	3/8	5/8		3/75	30	35	2.6	1340x900x320			
RAV-GM2801AT8-E			3/8						5/8	3/75	30
RAV-GP561ATP-E	3/8	5/8		3/75	30	35	2.6	1340x900x320			
RAV-GP801ATP-E			3/8						5/8	3/75	30
RAV-GP1101AT-E	3/8	5/8		3/75	30	35	2.6	1340x900x320			
RAV-GP1101AT8-E			3/8						5/8	3/75	30
RAV-GP1401AT-E	3/8	5/8		3/75	30	35	2.6	1340x900x320			
RAV-GP1401AT8-E			3/8						5/8	3/75	30
RAV-GP1601AT8-E	3/8	5/8		3/75	30	35	2.6	1340x900x320			

Performance & Electrical Specifications - DI / SDI R32 Single Splits

Model	Capacity kW		Ambient Range °C		Phase	Power To	Soft Start	Max. Running Current (A)	Suggested Fuse Size (A) #	Interconnect Cable		
	Cool	Heat	Cool	Heat								
Commercial Range												
RAV-GM301ATP-E	2.50	3.40	46 to -15	15 to -15	1Ph + N	Outdoor	Yes	3.75	10	3C + E		
RAV-GM401ATP-E	3.60	4.00						4.64				
RAV-GM561ATP-E	5.00	5.30						7.93				
RAV-GM801ATP-E	6.70	7.70						10.40	16			
RAV-GM901ATP-E	8.00	9.00						17.00	20			
RAV-GM1101ATP-E	9.50	11.20						14.20	20			
RAV-GM1101AT8P-E	9.50	11.20						4.75	10			
RAV-GM1401ATP-E	12.00	12.80						20.75	32			
RAV-GM1401AT8P-E	12.00	12.80						6.90	16			
RAV-GM1601ATP-E	14.00	16.00						29.00	32			
RAV-GM1601AT8P-E	14.00	16.00						16.10	20			
RAV-GM2241AT8-E	20.00	22.40						15 to -20	3Ph + N		9.52	16
RAV-GM2801AT8-E	23.50	27.00						13.03	20			
RAV-GP561ATP-E	5.30	5.60	52 to -15	15 to -27	1Ph + N	Outdoor	Yes	7.66	16			
RAV-GP801ATP-E	7.10	8.00						7.01	16			
RAV-GP1101AT-E	10.00	11.20						10.43	20			
RAV-GP1101AT8-E	10.00	11.20	46 to -15	15 to -20	3Ph + N	4.52	10					
RAV-GP1401AT-E	12.50	14.00	52 to -15	15 to -27	1Ph + N	14.55	25					
RAV-GP1401AT8-E	12.50	14.00	46 to -15	15 to -20	3Ph + N	Outdoor	Yes	6.03	16			
RAV-GP1601AT8-E	14.00	16.00						7.55	16			

Suggested fuse sizes are for guidance only, the electrical installation must be completed in-line with current electrical regulations, BS 7671:2018+A1, 2020 – 18th Edition, IET.

Model Outdoor	Twin Indoor	Triple Indoor	Quad Indoor	Phase	Power To	Inter-Connecting Cable
Commercial Range						
RAV-GM561ATP-E	RAV-RM301##-E	N/A	N/A	1Ph-N	Outdoor	3C+E
RAV-GM801ATP-E	RAV-RM401##-E					
RAV-GM901ATP-E	tbc					
RAV-GM1101ATP-E	RAV-RM561##-E	RAV-RM301##-E	3Ph+N			
RAV-GM1101AT8P-E	RAV-RM561##-E	RAV-RM301##-E				
RAV-GM1401ATP-E	RAV-RM801##-E	RAV-RM401##-E	RAV-RM301##-E	1Ph-N		
RAV-GM1401AT8P-E	RAV-RM801##-E	RAV-RM401##-E	RAV-RM301##-E	3Ph+N		
RAV-GM1601ATP-E	RAV-RM801##-E	RAV-RM561##-E	RAV-RM401##-E	1Ph+N		
RAV-GM1601AT8P-E	RAV-RM801##-E	RAV-RM561##-E	RAV-RM401##-E	3Ph+N		
RAV-GM2241AT8-E	RAV-RM1101##-E	RAV-RM801##-E	RAV-RM561##-E			
RAV-GM2801AT8-E	RAV-RM1101##-E	RAV-RM801##-E	RAV-RM561##-E			
RAV-GP561ATP-E	RAV-RM301##-E	N/A	N/A	1Ph-N		
RAV-GP801ATP-E	RAV-RM401##-E					
RAV-GP1101ATP-E	RAV-RM561##-E				RAV-RM301##-E	
RAV-GP1401ATP-E	RAV-RM801##-E	RAV-RM401##-E	RAV-RM301##-E			

Acoustic Data – DI/SDI Indoor Units

Model Indoor	High dB(A)	Med dB(A)	Low dB(A)	Model Indoor	High dB(A)	Med dB(A)	Low dB(A)
Commercial Range							
RAV-RM301KRTP-E	40	34	29	RAV-RM561BTP-E	33	29	25
RAV-RM401KRTP-E	41	36	30	RAV-RM801BTP-E	34	30	26
RAV-RM561KRT-E	42	39	36	RAV-RM901BTP-E	37	33	30
RAV-RM801KRT-E	45	41	35	RAV-RM1101BTP-E	40	36	33
RAV-RM901KRT-E	47	41	35	RAV-RM1401BTP-E	40	36	33
RAV-RM561UTP-E	32	29	28	RAV-RM1601BTP-E	40	36	33
RAV-RM801UTP-E	35	31	28	RAV-RM401CTP-E	37	35	28
RAV-RM901UTP-E	40	36	33	RAV-RM561CTP-E	37	35	28
RAV-RM1101UTP-E	43	38	33	RAV-RM801CTP-E	41	36	29
RAV-RM1401UTP-E	44	38	34	RAV-RM901CTP-E	42	38	30
RAV-RM1601UTP-E	45	40	36	RAV-RM1101CTP-E	44	38	32
RAV-RM301MUT-E	38	36	30	RAV-RM1401CTP-E	46	41	35
RAV-RM401MUT-E	41	36	32	RAV-RM1601CTP-E	46	42	36
RAV-RM561MUT-E	44	39	35	Note; Measured in Pressure Db(A)			
RAV-RM301SDT-E	39	36	33				
RAV-RM401SDT-E	39	36	33				
RAV-RM561SDT-E	45	40	36				

Acoustic Data – DI/SDI Outdoor Units.

Model Outdoor	Cooling dB(A)	Heating dB(A)	Model Outdoor	Cooling dB(A)	Heating dB(A)	Model Outdoor	Cooling dB(A)	Heating dB(A)
Commercial Range								
RAV-GM301ATP-E	46	47	RAV-RM401ATP-E	49	50	RAV-RM561ATP-E	46	48
RAV-RM801ATP-E	48	52	RAV-GM901ATP-E	51	52	RAV-RM1101ATP(8)-E	54	57
RAV-RM1401ATP(8)-E	54	57	RAV-GM1601ATP(8)-E	53	55	RAV-GM2241AT8-E	58	60
RAV-GM2801AT8-E	61	63						
RAV-GP561ATP-E	46	48	RAV-GP801AT-E	46	48	RAV-GP1101AT-E	49	50
RAV-GP1401AT-E	50	51						
Note; Measured in Pressure Db(A)								

Refrigerant Replacement Technology.

Existing piping connection with different diameter gas and liquid line is possible using the criteria detailed below.

Toshiba Digital and Super Digital R410A and R32 outdoor units have factory fitted filters installed which enables the reuse of existing pipework.

The existing pipework **MUST** be in good condition and have a wall thickness on a minimum 1mm.

When utilising R32 equipment, any joints within the building **MUST** be braze type, the final connection to the indoor unit can be of the flare type, all pipework **MUST** be mechanically protected.

Liquid Pipe Size in "		1/4 (STD)				3/8 (1-size larger)			
Gas Pipe Size in "		3/8 (STD)		1/2 (1-size larger)		3/8 (STD)		1/2 (1-size larger)	
Maximum Pipe Distance		Length	Pre-charged	Length	Pre-charged	Length	Pre-charged	Length	Pre-charged
		m	m	m	m	m	m	m	m
RAV-DI Series 4 – R410A Series 1 – R32	SM30*	20	15	20	15	13	7.5	13	7.5

Liquid Pipe Size in "		1/4 (STD)						3/8 (1-Size larger)			
Gas Pipe Size in "		3/8 (1-Size larger)		1/2 (STD)		5/8 (1-Size larger)		1/2 (STD)		5/8 (1-Size larger)	
Maximum Distance		Length	Pre-charged	Length	Pre-charged	Length	Pre-charged	Length	Pre-charged	Length	Pre-charged
		m	m	m	m	m	m	m	m	m	m
RAV-DI Series 2 – R410A Series 1 – R32	SM/RM40*	20	15	20	15	20	15	13	7.5	13	7.5
	SM/RM56*			30	20	30	20	20	10	20	10
RAV-SDI Series 4 – R410A Series 1 – R32	SP/GP40*	30	20	30	20	30	20	20	10	20	10
	SP/GP56*			50	20	50	20	20	10	20	10

Liquid Pipe Size in "		1/4 (1-Size smaller)				3/8 (STD)				1/2 (1-Size larger)					
Gas Pipe Size in "		1/2 (1-Size smaller)		5/8 (STD)		1/2 (1-Size smaller)		5/8 (STD)		3/4 (1-Size larger)		5/8 (STD)		3/4 (1-Size larger)	
Maximum Distance		Length	Pre-charged	Length	Pre-charged	Length	Pre-charged	Length	Pre-charged	Length	Pre-charged	Length	Pre-charged	Length	Pre-charged
		m	m	m	m	m	m	m	m	m	m	m	m	m	m
RAV-DI Series 4 – R410A Series 1 – R32	SM/RM80*	20	20	20	20	30	20	30	20	30	20				
	SM/GM110*							50	30	50	30	25	15	25	15
	SM/GM140*							50	30	50	30	25	15	25	15
RAV-DI Series 3 – R410A	SM160*							50	30	50	30	25	15	25	15
	SP/GP80*	30	20	30	20	50	30	50	30	50	30				
	SP/GP110*							75	30	75	30	25	15	25	15
RAV-SDI Series 4 – R410A Series 1 – R32	SP/GP140*							75	30	75	30	25	15	25	15

Liquid Pipe Size in "		1/2 (STD)				5/8 (1-size larger)			
Gas Pipe Size in "		7/8 (1-Size smaller)		1- 1/8 (STD)		7/8 (1-Size smaller)		1- 1/8 (STD)	
Maximum Distance		Length	Pre-charged	Length	Pre-charged	Length	Pre-charged	Length	Pre-charged
		m	m	m	m	m	m	m	m
RAV-DI Series 1 R32	GM224*	60	30	60	30	50	20	50	20
	GM280*	60	30	60	30	50	20	50	20

Code	
	Smaller pipe sizes (Performance capacity is reduced due to the effect of the gas pipe size being smaller than the standard – 1-size smaller)
	Normal pipe size (STD)
	Larger pipe size (1-size larger)
	Not compatible

Replacement technology piping specification RAS

Existing piping connection with different diameter gas and liquid line is possible using the following criteria.

Liquid Pipe Size in "		1/4 (STD)		3/8 (STD)	
Gas Pipe Size in "		3/8 (STD)		1/2 (STD)	
Maximum Distance		Length	Pre-charged	Length	Pre-Charged
		m	m	m	m
MIRAI / SEIYA	*10*	15	15		
	13	15	15		
	16			20	15
	18			20	15
	24			20	15
SHORAI	*10*	20	15		
	13	20	15		
	18			20	15
	22			20	15
	24			20	15

Common Refrigerants
for Existing Plant.
R22
R407C

Conversion of RAV-GM/GP (R32) units for use with R410A

The Current range of Toshiba R32 light commercial RAV-GM (Digital Inverter) and RAV-GP (Super Digital) Inverter outdoor units are compatible with refrigerant R410A, subject to compliance with current f-gas regulations.

It is the installers responsibility to.

Undertake the conversion from R32 to R410A in full compliance with current f-gas regulations.

Remove the R32 labelling from the outdoor unit and replaced with a suitable R410A label, in accordance with current f-gas regulations.

HP	Model Name	NEW Pre-charged R410A(kg)	Pre-charged length (m) (a)	Maximum Length (m)	Additional charge per meter (grams) (b)	Original R32 Charge (kg)
1	RAV-GM301ATP-E	0.76	15	20	20	0.63
1.5	RAV-GM401ATP-E	1.08	15	20	20	0.9
2	RAV-GM561ATP-E	1.08	20	30	20	0.9
3	RAV-GM801ATP-E	1.56	20	30	40	1.3
4	RAV-GM1101ATP-E	2.52	30	50	40	2.1
4	RAV-GM1101AT8P-E	2.52	30	50	40	2.1
5	RAV-GM1401ATP-E	2.52	30	50	40	2.1
5	RAV-GM1401AT8P-E	2.52	30	50	40	2.1
2	RAV-GP561ATP-E	1.62	20	50	40	1.35
3	RAV-GP801AT-E	2..28	30	50	40	1.9
4	RAV-GP1101AT-E	3.72	30	75	40	3.1
5	RAV-GP1401AT-E	3.72	30	75	40	3.1
4	RAV-GP1101AT8-E	3.12	30	75	40	2.6
5	RAV-GP1401AT8-E	3.12	30	75	40	2.6
6	RAV-GP1601AT8-E	3.12	30	75	40	2.6
8	RAV-GM2241AT8-E	6.0	30	100	80	5.0
10	RAV-GM2801AT8-E	6.0	30	100	80	5.0

Example.

Additional refrigerant charge amount at site exceeding pre-charged length (a)	=	Real length of liquid pipe -Pre-charged length (a)	X	Additional refrigerant charge (grams) amount per liquid pipe 1m (b)
---	---	---	---	---

RAV-GM1101ATP-E installed pipe length 40m
 Additional charge 40m – 30m = 10m x 40g (b) = 400grams
 Pre-charged 2.52 (kg) + 0.4 (kg) additional charge = 2.92 kg system charge.

**Changers to standard units must be safely managed and undertaken in accordance with, EC Regulation 517/2014 (F-Gas regulations).
 And in accordance with The Dangerous Substances and Explosive Atmospheres Regulation 2002 including Hazard Classes H220, H221 and H280 and Approved Code of Practice (ACOP)**

R32 in Occupied Spaces

R32 Refrigerant is classified as "A2L" Which is a Refrigerant that is classed as being "Lower Flammability" rated. Due to the "Lower Flammability" rating R32 installations need to meet the "Quantity Limit with Minimum Ventilation" - "QLMV"

This quick guide is designed to assist in calculating the maximum quantity of R32 in an occupied space. In accordance with EN378/2016.

The following assumptions have been used within this calculation:

- 1) Location Classification:- Class II. Indoor units and pipe work within conditioned space. Outdoor unit located in machine room. Plant room or in open air.**
- 2) Access Classification: Class B, Limited number of people some of which are acquainted with general safety precautions. May be a room or part of a building.**
- 3) Category Classification: Human Comfort, air treatment for occupants.**

The formula used to calculate the quantity of R32 refrigerant safely allowed in an occupied space is:

$$M = 2.5 \times LFL1.25 \times h_o \times VA$$

The following chart is a "Quick Guidance" to assess the acceptable quantity of R32 in the respective floor area, full detailed calculation should be carried out for each installation.

Sq. Area (m ²)	Ceiling (2.2m) kg	Wall (1.8m) kg	Window (1m) kg	Floor (0.6m) kg
1	1.26	1.03	0.57	0.34
2	1.78	1.45	0.81	0.48
3	2.18	1.78	0.99	0.59
4	2.51	2.06	1.14	0.69
5	2.81	2.30	1.28	0.77
6	3.08	2.52	1.40	0.84
7	3.33	2.72	1.51	0.91
8	3.55	2.91	1.62	0.97
9	3.77	3.09	1.71	1.03
10	3.97	3.25	1.81	1.08
11	4.17	3.41	1.89	1.14
12	4.35	3.56	1.98	1.19
13	4.53	3.71	2.06	1.24
14	4.70	3.85	2.14	1.28
15	4.87	3.98	2.21	1.33
16	5.03	4.11	2.29	1.37
17	5.18	4.24	2.36	1.41
18	5.33	4.36	2.42	1.45
19	5.48	4.48	2.49	1.49
20	5.62	4.60	2.55	1.53

Where the systems refrigerant charge exceeds the above, mechanical ventilation and or refrigerant leak detectors should be utilised.

For more detailed calculations please contact Cool Designs Technical Support or visit Toshiba Air Conditioning business club web site: <http://www.toshiba-calc.co.uk/r32-charge/>

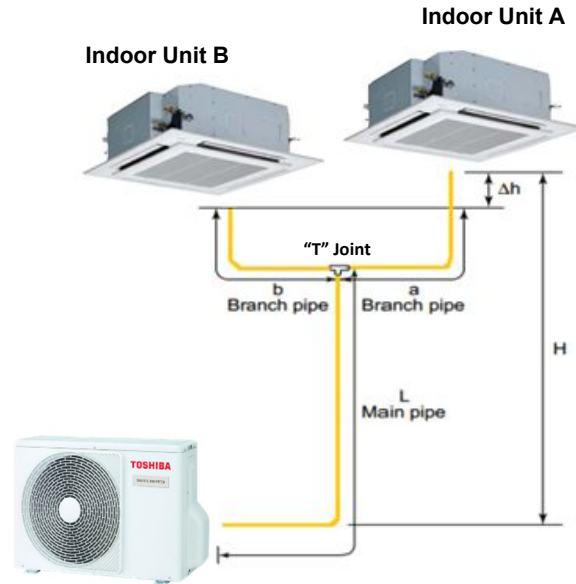

Pipe Specifications

Model (RAV-)	Allowable Piping Length (m)			Height Difference (m)		Number of bent portions Maximum or less (Qty)
	*Total length (L+a or L+b) Maximum	†Branch Pipe A or b to furthest indoor Maximum	‡Subtractive piping length a-b or b-a Maximum	Outdoor to Indoor Maximum (+/-)	Indoor unit's height difference (Δh) Maximum	
GM561ATP-E	30	10	5	30	0.5	10
GM801ATP-E						
GM1101ATP(8)-E	50	15	10	30	0.5	10
GM1401ATP(8)-E						
GM1601ATP(8)-E						
GM2241AT8-E						
GM2801AT8-E	60	20	10	30	0.5	10
GP561ATP-E						
GP801AT-E	50	15	10	30	0.5	10
GP1101AT(8)-E						
GP1401AT(8)-E						
GP1601AT(8)-E						

• Data to be ratified by manufacturer.

‡Maximum subtractive distance between pipe branches. Example: -

Example 1 (RAV-GM561/801ATP-E)

Installed length main pipe L to distributor=18m

Installed length branch a=10m (Max. 10m)

Installed length branch b=6m

Example 2 (RAV-GM561/801ATP-E)

Installed length main pipe L to distributor=28m

Installed length branch a=14m (Max. 10m)

Installed length branch b=2m

Example 3 (RAV-GM1101/1401/SP561/801/1101/1401/1601AT(P)-E)

Installed length main pipe L to distributor=35m

Installed length branch a=12m (Max. 15m)

Installed length branch b=10m

Example 4 (RAV-

GM1101/1401/SP561/801/1101/1401/1601AT(P)-E)

Installed length main pipe L to distributor=60m

Installed length branch a=14m (Max. 15m)

Installed length branch b=2m

Example 1 ✓

Total pipe length L + a 18 + 10 = 28m ✓

Subtractive pipe length a - b 10 - 6 = 4m ✓

Example 2 ✗

Total pipe length L + a 28 + 14 = 42m ✗

Subtractive pipe length a - b 14 - 2 = 12m ✗

Example 3 ✓

Total pipe length L + a 35 + 12 = 47m ✓

Subtractive pipe length a - b 12 - 10 = 2m ✓

Example 4 ✗

Total pipe length L + a 60 + 14 = 74m ✗

Subtractive pipe length a - b 14 - 2 = 12m ✗

Additional Charge

Model (RAV-)	Main Pipes			Branch Pipes		
	Sizes (") Gas/Liquid	Pre-charge Factor (m)	Add Amount (kg/m) – [α]	Sizes (") Gas/Liquid	Pre-charge Factor (m)	Add Amount (kg/m) – [β]
GM561ATP-E	1/2 - 1/4	28	0.020	3/8 - 1/4	2	0.020
GM801ATP-E	5/8 - 3/8		0.035	1/2 - 1/4		
GM1101ATP(8)-E				5/8 - 3/8		0.035
GM1401ATP(8)-E						
GM1601ATP(8)-E				1/2 - 1/4		0.020
GM2241AT8-E	5/8 - 3/8		0.035	3/8 - 1/4		
GM2801AT8-E				1/2 - 1/4		0.020
GP561ATP-E	5/8 - 3/8		0.035	1/2 - 1/4		
GP801AT-E				5/8 - 3/8		0.035
GP1101AT(8)-E						
GP1401AT(8)-E				5/8 - 3/8		0.035
GP1601AT(8)-E						

• Data to be ratified by manufacturer.

Gas calculation - [Main pipe] (L-**28**) x α + [Branch Pipe] (a+b - **4**) x β = additional charge

Example 1

Installed length main pipe L to distributor=38m

Installed length branch a=12m

Installed length branch b=10m

Example 1 using	GM1101ATP-E				
Total pipe length	L - 28 x α	38 - 28	= 10 x 0.035 =	0.35 +	
Branch pipe length	a + b x β	12 + 10 - 4	= 18 x 0.035 =	0.63	
			Add Amount	0.98 kg	

NOTES:

Digital / Super Digital Inverter Triple Splits

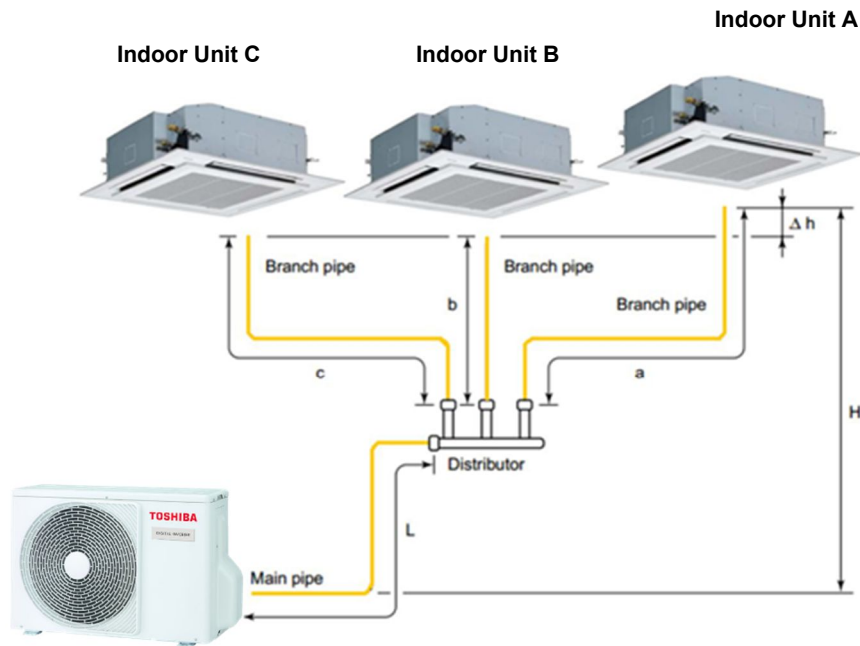

Pipe Specifications

Model (RAV-)	Allowable Piping Lengths (m)			Height Difference (m)		Number of bent portions Maximum or Less (Qty)
	*Total Length La + Lb La + Lc Maximum	†Branch Piping La, Lb or Lc to Furthest Indoor Maximum	‡Subtractive Piping Length Lb - La Lb - Lc Maximum	Outdoor to Indoor Maximum (+/-)	Indoor Unit Height Difference (Δh) Maximum	
GM1101ATP(8)-E	50	15	10	30	0.5	10
GM1401ATP(8)-E						
GM1601ATP(8)-E						
GM2241AT8-E		20				
GM2801AT8-E						
GP1101AT(8)-E		15				
GP1401AT(8)-E						
GP1601AT(8)-E						

• Data to be ratified by manufacturer.

†Maximum distance of Branch pipe from main pipe distributor to furthest indoor unit.

‡Maximum subtractive distance between pipe branches. Example: -

Example 1

Installed length main pipe L to distributor=38m Installed length branch =12m
Installed length branch b=10m Installed length branch c=12m

Example 2

Installed length main pipe L to distributor=40m Installed length branch a=15m
Installed length branch b=4m Installed length branch c=12m

Example 1 ✓

Total pipe length L + a	38	+	12	=	50m	✓
Subtractive pipe length a - b	12	-	10	=	2m	✓
Subtractive pipe length c - b	12	-	10	=	2m	✓

Example 2 ✗

Total pipe length L + a	40	+	15	=	55m	✗
Subtractive pipe length a - b	15	-	4	=	11m	✗
Subtractive pipe length c - b	12	-	4	=	8m	✓

Additional Charge

Model (RAV-)	Main Pipes			Branch Pipes		
	Sizes (") Gas/Liquid	Pre-charge Factor (m)	Add Amount (kg/m) – [α]	Sizes (") Gas/Liquid	Pre-charge Factor (m)	Add Amount (g/m) – [β]
GM1101ATP(8)-E	5/8 – 3/8	28	0.035	3/8 – 1/4	6	0.020
GM1401ATP(8)-E				1/2 – 1/4		
GM1601ATP(8)-E						
GM2241AT8-E	1 -1/8 – 1/2		0.080	5/8 – 3/8		0.040
GM2801AT8-E						
GP1101AT(8)-E	5/8 – 3/8		0.035	3/8 – 1/4		0.020
GP1401AT(8)-E				1/2 – 1/4		
GP1601AT(8)-E						

- Data to be ratified by manufacturer.

Gas calculation - [Main pipe] (L-**28**) x α + [Branch Pipe] (a+b+c - **6**) x β = additional charge

Example 1

Installed length main pipe L to distributor=38m
 Installed length branch a=12m
 Installed length branch b=10m
 Installed length branch c=12m

Example 1 above using GM1401ATP(8)-E

Total pipe length L - **28** x α 38 - 28 = 10 x 0.035 = 0.35 +
 Branch pipe length a + b + c x β 12+10+ 12- **6** = 28 x 0.035 = 0.98
 Add Amount 1.33 kg

Example 1 above using GP1101AT-E

Total pipe length L - **28** x α 38 - 28 = 10 x 0.035 = 0.35 +
 Branch pipe length a + b + c x β 12+10+ 12- **6** = 28 x 0.020 = 0.56
 Add Amount 0.91 kg

NOTES:

Digital Inverter Quad Splits

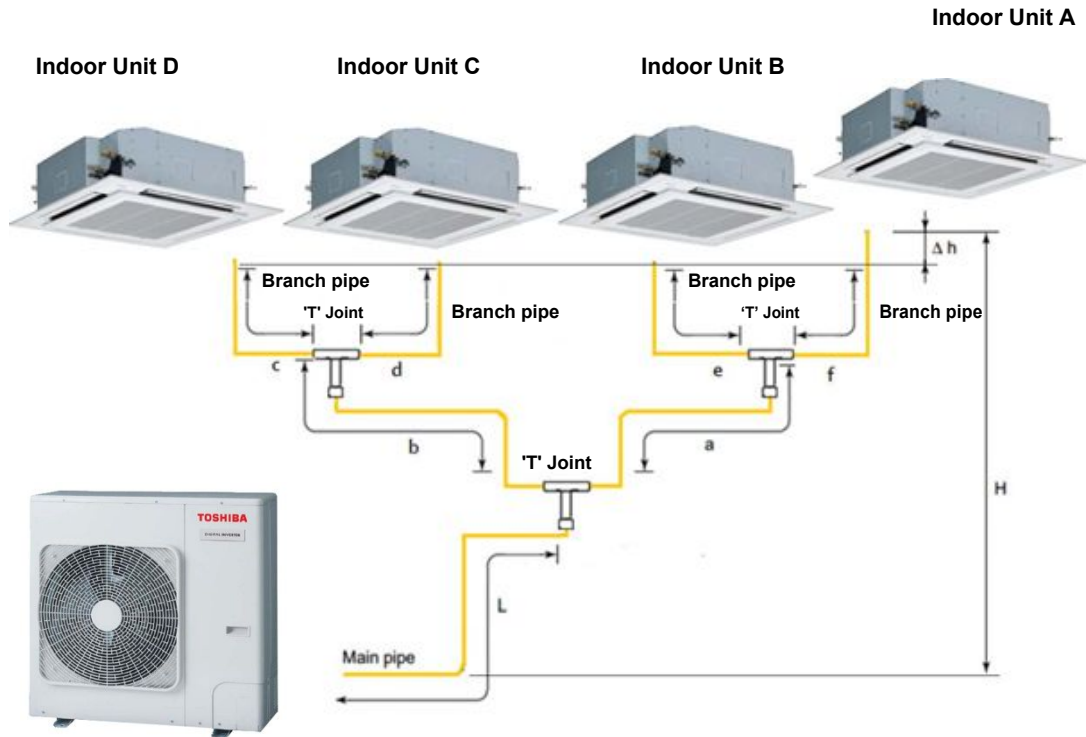

Pipe Specifications

Model (RAV-)	Allowable Piping Lengths (m)				Height Difference (m)		Number of bent portions Maximum or Less (Qty)
	*Total Length (L+b+c) or (L+b+d) or (L+a+e) or (L+a+f) Maximum	†Branch Piping c, d, e & f to Furthest Indoor Maximum	‡Branch Piping b+c b+d a+e a+f Maximum	‡Subtractive Branch Piping (c+b) - (d+b) (c+b) - (e+a) (c+b) - (f+a) (d+b) - (e+a) (d+b) - (f+a) (e+a) - (f+a) Maximum	Outdoor to Indoor Maximum (+/-)	Indoor Unit Height Difference (Δh) Maximum	
GM1401ATP(8)-E	50	10	15	5	30	0.5	10
GM1601ATP(8)-E							
GM2241AT8-E	60		20	6			
GM2801AT8-E							
GP1401AT(8)-E	50	15	5				
GP1601AT(8)-E							

• Data to be ratified by manufacturer.

*Total length of pipe between furthest indoor and outdoor unit.

†Maximum distance of Branch pipe from main pipe distributor to furthest indoor unit.

‡Maximum pipe distance between Branched pairs

‡Maximum subtractive distance between pipe branches. Example: -

Example 1

Installed length main pipe L to distributor=20m

Installed length branch b=10m

Installed length branch c=5m

Installed length branch d=5m

Installed length branch a=10m

Installed length branch e=5m

Installed length branch f=5m

Example 1 ✓

Total pipe length L + b + c	20 + 10 + 5=	35m✓
Branch length b + d	10 + 5=	15m✓
Branch length a + e	10 + 5=	15m✓
Branch length a + f	10 + 5=	15m✓
Subtractive pipe length c+b - d+b	5+10 - 5+10=	0m✓
Subtractive pipe length c+b - e+a	5+10 - 5+10=	0m✓
Subtractive pipe length c+b - f+a	5+10 - 5+10=	0m✓
Subtractive pipe length d+b - e+a	5+10 - 5+10=	0m✓
Subtractive pipe length d+b - f+a	5+10 - 5+10=	0m✓
Subtractive pipe length e+a - f+a	5+10 - 5+10=	0m✓

Example 2

Installed length main pipe L to distributor=30m
 Installed length branch b=15m
 Installed length branch c=10m
 Installed length branch d=6m
 Installed length branch a=15m
 Installed length branch e=5m
 Installed length branch f=10m

Example 2 ✖			
Total pipe length L + b + c	30+ 15 +10	=	55m✖
Branch length b + c	15+ 10	=	25m✖
Branch length b + d	15+ 6	=	21m✖
Branch length a + e	15+ 5	=	20m✖
Branch length a + f	15+ 10	=	25m✖
Subtractive pipe length c+b - d+b	10+ 15-	6+ 15	= 4m✓
Subtractive pipe length c+b - e+a	10+ 15-	5+ 15	= 5m✓
Subtractive pipe length c+b - f+a	10+ 15-	10+ 15	= 0m✓
Subtractive pipe length d+b - e+a	6+ 15-	5+ 15	= 1m✓
Subtractive pipe length d+b - f+a	6+ 15-	10+ 15	= 1m✓
Subtractive pipe length e+a - f+a	6+ 15-	10+ 15	= 1m✓

Additional Charge

Model (RAV-)	Main Pipes			Branch pipes				
	Sizes Gas/Liquid (")	Pre-charge Factor (m)	Add amount (kg/m) – [α]	Sizes Gas/Liquid (")	Pre-charge Factor (m)	Add amount (g/m) – [β]	Sizes Gas/Liquid(")	Add amount (g/m) – [γ]
GM1401ATP(8)-E	5/8 – 3/8	28	0.035	3/8 – 1/4	4	0.020	1/2 – 1/4	0.020
GM1601ATP(8)-E				5/8 – 3/8				
GM2241AT8-E	1 -1/8 – 1/2		0.080	5/8 – 3/8		0.040	5/8 – 3/8	0.040
GM2801AT8-E	5/8 – 3/8		0.035	3/8 – 1/4		0.020	1/2 – 1/4	0.020
GP1401AT(8)-E	5/8 – 3/8							
GP1601AT(8)-E								

• Data to be ratified by manufacturer.

Gas calculation - [Main pipe] (L-28) x α + [Branch Pipe a] (a+b - 4) x β + [Sub Branch Pipe] (c+d+e+f) x γ = additional charge

Example 1

Installed length main pipe L to distributor=20m
 Installed length branch b=10m
 Installed length branch c=5m
 Installed length branch d=5m
 Installed length branch a=10m
 Installed length branch e=5m
 Installed length branch f=5m

Example 1 using GM1401ATP(8)-E			
Total pipe length	L - 28 x α	20 - 28	= -8 x 0.035 = -0.28 +
Branch pipe length	a + b - 4 x β	10+10- 4	= 16 x 0.020 = 0.32 +
Branch pipe length	c + d + e + f x γ	5+5+5+5	= 20 x 0.020 = 0.40
			Add Amount 0.44 kg

Digital / Super Digital Multi Split System Wiring Schematic

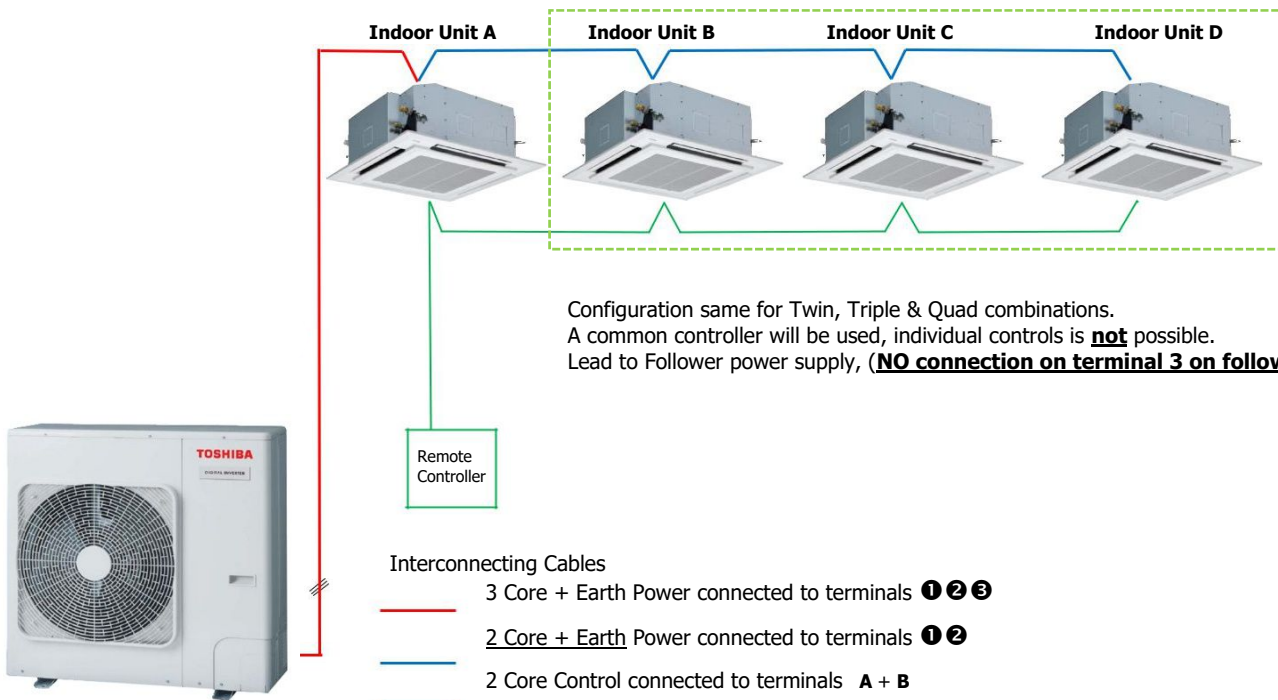

Common Sensor Characteristics

There are eight commonly used sensors in the **RAS** and **RAV** systems.

TA = Return Air Sensor; indoor unit

TC = Coil Sensor; indoor unit

TCJ = Coil Sensor; indoor unit

TL = Liquid Pipe Sensor (fan speed); outdoor unit

TE = Heat Exchange Sensor (defrost); outdoor unit

TD = Discharge Pipe Sensor; outdoor unit

TO = Ambient; outdoor unit

TS = Suction; outdoor unit

TK = Oil sensor (VRF)

The Ta,Tc,Tcj,Ts,To and TE sensors all share the same resistance versus temperature characteristic. They differ however in electrical connections and sensing head style; therefore, it is important to quote the full model type number when ordering any replacement sensors.

The Td, TL and TK sensor has a different resistance characteristic because its sensing range is that much higher than the others.

Sensor	-10	-5	0	5	10	15	20	25	30	35	40	45	50	55	60	100	°C
Ta,Tc,Tcj,TE,To, Ts	60.3	45.3	33.8	26.4	20.35	16	12.59	10	8	6.5	5.2	4.3	3.5	2.9	2.4	-	KΩ
Td, Tk, TL	-	-	161	-	99	80.5	63	50	40	-	26.5	-	17.9	-	12.3	3.4	kΩ

Example for location of sensors

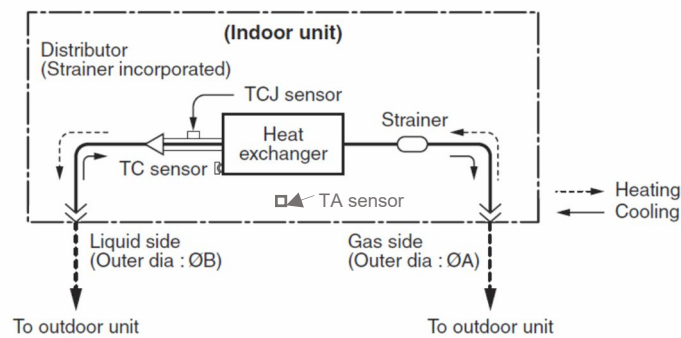

GP1101/1401

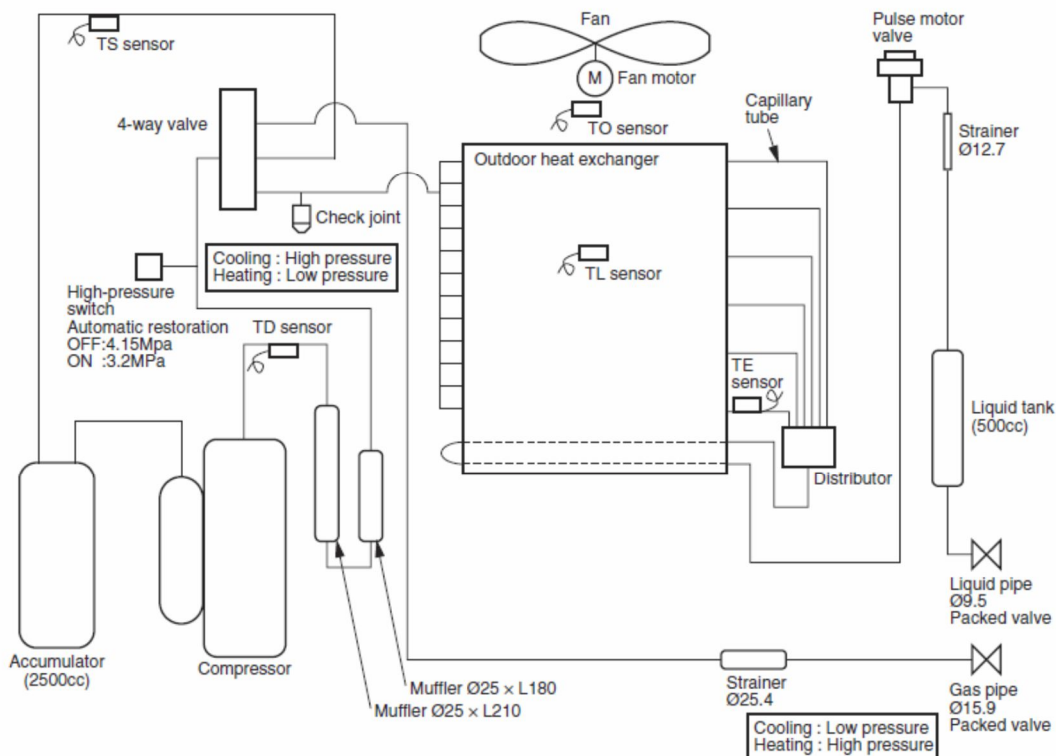

Indoor Lamp Indication for Trouble Shooting - RAV ###KRT (High Wall Only)

● : Go off, ○ : Go on, ⚡ : Flash (0.5 sec.)

Lamp Indication	Check code	Cause of trouble occurrence		
 No Indication at all	—	Power supply OFF or miswiring between receiving unit and indoor unit		
 Alternate flash	E01	Receiving error } Receiving unit } Miswiring or wire connection error between receiving unit and indoor unit		
	E02		Sending error	
	E03		Communication stop	
	 Alternate flash	E08	Duplicated indoor unit No. } Duplicated master units of remote controller } Setup error	
		E09		
		E10		Communication error between CPUs on indoor unit P.C. board
E18	Wire connection error between indoor units, Indoor power OFF (Communication stop between indoor master and follower or between main and sub indoor twin)			
 Flash	E04	Miswiring between indoor unit and outdoor unit or connection error (Communication stop between indoor and outdoor units)		
 Alternate flash	P01	Indoor AC fan error		
	P10	Overflow was detected. Protective device of indoor unit worked.		
	P12	Indoor DC fan error		
 Alternate flash	P03	Outdoor unit discharge temp. error		
	P04	Outdoor high pressure system error		
	P05	Case thermostat worked		
	P07	Power supply error		
	P15	Power supply error		
	P19	Heat sink overheat error		
	P20	Gas leak detection error		
	P22	4-way valve system error (Indoor or outdoor unit judged.)		
	P26	Outdoor unit high pressure protection		
	P29	Outdoor unit: Outdoor unit error		
 Alternate flash	P31	Outdoor unit: Inverter Idc operation		
	P31	Outdoor unit: Position detection error		
	P31	Stopped because of error of other indoor unit in a group (Check codes of E03/L03/L07/L08)		
 Simultaneous flash	—	During test run		
 Alternate flash	—	Disagreement of cool/heat (Automatic cool/heat setting to automatic cool/heat prohibited model, or setting of heating to cooling-only model)		

Lamp indication	Check code	Cause of trouble occurrence
 Alternate flash	F01	Heat exchanger sensor (TC.J) error
	F02	Heat exchanger sensor (TC) error
	F10	Heat exchanger sensor (TA) error
 Alternate flash	F04	Discharge temp. sensor (TD) error
	F06	Temp. sensor (TL, TS, TE) error
	F07	Temp. sensor (TD) error
	F08	Temp. sensor (TO) error
	F12	Temp. sensor (TS) error
	F13	Heat sink sensor (TH) error
	F15	Temp. sensor miswiring (TE, TS)
 Simultaneous flash	F29	Indoor EEPROM error
 Simultaneous flash	F31	Outdoor EEPROM error
 Flash	H01	Compressor break down
	H02	Compressor lock
	H03	Current detection circuit error
	H04	Case thermostat worked.
 Simultaneous flash	L03	Duplicated master indoor units
	L07	There is indoor unit of group connection in individual indoor unit.
	L08	Unsetting of group address
	L09	Missed setting (Unset indoor capacity)
	L10	Unset model type (Service board)
 Simultaneous flash	L20	Duplicated indoor central addresses
	L29	Temp. sensor (TH) error EEPROM error Communication between outdoor MCU Heat sink overheat error Gas leak detection error 4-way valve error
	L30	Outside interlock error

The primary judgement to check whether a fault has occurred in the indoor or outdoor unit is carried out with the following method; method to judge the erroneous position by flashing indication on the display part of the indoor unit. The indoor unit monitors the operating status of the air conditioner and the blocked contents of self-diagnosis are displayed restricted to the above cases if a protective circuit works.

Indoor Lamp Indication for Trouble Shooting – RAV###KRT (High Wall Only)

Check Code List (Indoor)

○ : Go on, ◎ : Flash, ● : Go off ALT (Alternate): Alternate flashing when there are two flashing LED SIM (Simultaneous): Simultaneous flashing when there are two flashing LED

(Indoor unit detected)

Check code indication	Sensor lamp indication				Representative defective position	Explanation of error contents	Air conditioner operation	
	Block indication						Automatic reset	Operation continuation
Wired remote controller	Ready	Timer	Operation	Flash				
E03	●	●	◎		Regular communication error between indoor and remote controller	No communication from remote controller and network adapter (Also no communication from central control system)	○	×
E04	◎	●	●		Indoor/Outdoor serial error	There is error on serial communication between indoor and outdoor units	○	×
E08	●	●	◎		Duplicated indoor addresses	Same address as yours was detected.	○	×
E18	●	●	◎		Regular communication error between indoor master and follower units	Regular communication between indoor master and follower units is impossible, Communication between twin master (main) and follower (sub) units is impossible.	○	×
F01	●	◎	◎	ALT	Indoor unit, Heat exchanger (TCJ) error	Open/short was detected on heat exchanger (TCJ).	○	×
F02	●	◎	◎	ALT	Indoor unit, Heat exchanger (TC) error	Open/short was detected on heat exchanger (TC).	○	×
F10	●	◎	◎	ALT	Indoor unit, Room temp. sensor (TA) error	Open/short was detected on room temp. sensor (TA).	○	×
F29	●	◎	◎	SIM	Indoor unit, other indoor P.C. board error	EEPROM error (Other error may be detected. If no error, automatic address is repeated.	×	×
L03	◎	●	◎	SIM	Duplicated setting of indoor group master unit	There are multiple master units in a group.	×	×
L07	◎	●	◎	SIM	There is group cable in individual indoor unit.	When even one group connection indoor unit exists in individual indoor unit.	×	×
L08	◎	●	◎	SIM	Unset indoor group address	Indoor group address is unset.	×	×
L09	◎	●	◎	SIM	Unset indoor capacity	Capacity of indoor unit is unset.	×	×
L20	◎	○	◎	SIM	Duplicated central control system address	Duplicated setting of central control system address	○	×
L30	◎	○	◎	SIM	Outside error input to indoor unit (Interlock)	Abnormal stop by outside error (CN80) input	×	×
P12	◎	◎	●	ALT	Indoor unit, DC fan error	Indoor DC fan error (Over-current/Lock, etc.) was detected.	×	×
P19	◎	●	◎	ALT	4-way valve system error	In heating operation, an error was detected by temp. down of indoor heat exchanger sensor.	○	×
P31	◎	●	◎	ALT	Other indoor unit error	Follower unit in group cannot operate by warning from [E03/L03/L07/L08] of master unit.	○	×

◇ When this warning was detected before group construction/address check finish at power supply was turned on, the mode shifts automatically to AUTO address setup mode.

(Remote controller detected)

Check code indication	Sensor lamp indication				Representative defective position	Explanation of error contents	Air conditioner operation	
	Block indication						Automatic reset	Operation continuation
Wired remote controller	Ready	Timer	Operation	Flash				
E01	●	●	◎		No master remote controller, Remote controller communication (Receive) error	Signal cannot be received from indoor unit. Master remote controller was not set. (including 2 remote controllers)	—	—
E02	●	●	◎		Remote controller communication (Send) error	Signal cannot be sent to indoor unit.	—	—
E09	●	●	◎		Duplicated master remote controller	In 2-remote controller control, both were set as master. (Indoor master unit stops warning and follower unit continues operation.)	×	△

(Central control devices detected)

Check code indication	Sensor lamp indication				Representative defective position	Explanation of error contents	Air conditioner operation	
	Block indication						Automatic reset	Operation continuation
TCC-LINK central	Ready	Timer	Operation	Flash				
C05	Is not displayed. (Common use of remote controller, etc.)				Central control system communication (send) error	Signal sending operation of central control system is impossible. There are multiple same central devices. (AI-NET)	—	—
C06					Central control system communication (receive) error	Signal receiving operation of central control system is impossible.	—	—
C12	—				General-purpose device control interface batched warning	An error on device connected to general-purpose device control interface of exclusive to TCC-LINK/AI-NET	—	—
P30	By warning unit (Above-mentioned)				Group follower unit is defective.	Group follower unit is defective. (For remote controller, above-mentioned [***] details are displayed with unit No.	—	—

NOTE: Even for the same contents of error such as communication error, the display of check code may differ according to detection device. When remote controller or central controller detects an error, it is not necessarily related to operation of the air conditioner. In this list, the check codes that outdoor unit detects are not described.

The primary judgment to check whether a fault has occurred in the indoor unit or outdoor unit is carried out with the following method; method to judge the erroneous position by flashing indication on the display part of the indoor unit. The indoor unit monitors the operating status of the air conditioner and the blocked contents of self-diagnosis are displayed restricted to the above cases if a protective circuit works.

Indoor Lamp Indication for Trouble Shooting - RAV Series

● : Go off, ○ : Go on, ✱ : Flash (0.5 sec.)

Lamp indication	Check code	Cause of trouble occurrence
Operation Timer Ready ● ● ● No indication at all	—	Power supply OFF or miswiring between receiving unit and indoor unit
Operation Timer Ready ✱ ● ● Flash	E01	Receiving error } Receiving unit } Miswiring or wire connection error Sending error } between receiving unit and indoor unit Communication stop }
	E02	
	E03	
	E08	Duplicated indoor unit No. } Setup error Duplicated master units of remote controller }
	E09	
	E10	Communication error between CPUs on indoor unit P.C. board
E18	Wire connection error between indoor units, Indoor power OFF (Communication stop between indoor master and follower or between main and sub indoor twin)	
Operation Timer Ready ● ● ✱ Flash	E04	Miswiring between indoor unit and outdoor unit or connection error (Communication stop between indoor and outdoor units)
Operation Timer Ready ● ✱ ✱ Alternate flash	P10	Overflow was detected. } Protective device of indoor unit worked. Indoor DC fan error }
	P12	
Operation Timer Ready ✱ ● ✱ Alternate flash	P03	Outdoor unit discharge temp. error } Protective device of outdoor unit worked. *1 Outdoor high pressure system error }
	P04	
	P05	Negative phase detection error } Outdoor unit error Heat sink overheat error } Gas leak detection error }
	P07	
	P15	
	P19	4-way valve system error (Indoor or outdoor unit judged.)
	P20	Outdoor unit high pressure protection
	P22	Outdoor unit: Outdoor unit error } Protective device of outdoor unit worked. *1 Outdoor unit: Inverter Idc operation } Outdoor unit: Position detection error }
P26		
P29		
P31	Stopped because of error of other indoor unit in a group (Check codes of E03/L03/L07/L08)	
Operation Timer Ready ✱ ✱ ✱ Simultaneous flash	—	During test run
Operation Timer Ready ○ ✱ ✱ Alternate flash	—	Disagreement of cool/heat (Automatic cool/heat setting to automatic cool/heat prohibited model, or setting of heating to cooling-only model)

Lamp indication	Check code	Cause of trouble occurrence
Operation Timer Ready ✱ ✱ ● Alternate flash	F01	Heat exchanger sensor (TCJ) error Heat exchanger sensor (TC) error Indoor unit sensor error Heat exchanger sensor (TA) error
	F02	
	P10	
Operation Timer Ready ✱ ✱ ○ Alternate flash	F04	Discharge temp. sensor (TD) error Temp. sensor (TE) error Temp. sensor (TL) error Temp. sensor (TO) error Sensor error of outdoor unit *1 Temp. sensor (TS) error Temp. sensor (TH) error Temp. Sensor miswiring (TE, TS)
	F06	
	F07	
	F08	
	F12	
	F13	
F15		
Operation Timer Ready ✱ ✱ ● Simultaneous flash	F29	Indoor EEPROM error
Operation Timer Ready ✱ ✱ ○ Simultaneous flash	F31	Outdoor EEPROM error
Operation Timer Ready ● ✱ ● Flash	H01	Compressor break down Compressor lock Current detection circuit error Outdoor compressor system error *1 Case thermostat worked. Outdoor unit low pressure system error
	H02	
	H03	
	H04	
	H06	
Operation Timer Ready ✱ ● ✱ Simultaneous flash	L03	Duplicated master indoor units There is indoor unit of group connection in individual indoor unit. → AUTO address Unsetting of group address Missed setting (Unset indoor capacity) * If group construction and address are not normal when power supply turned on, automatically goes to address setup mode.
	L07	
	L08	
	L09	
Operation Timer Ready ✱ ○ ✱ Simultaneous flash	L10	Unset model type (Service board) Duplicated indoor central addresses Outdoor unit and other error Others Outside interlock error Negative phase error
	L20	
	L29	
	L30	
	L31	

The primary judgment to check whether a fault has occurred in the indoor unit or outdoor unit is carried out with the following method; method to judge the erroneous position by flashing indication on the display part of the indoor unit. The indoor unit monitors the operating status of the air conditioner and the blocked contents of self-diagnosis are displayed restricted to the above cases if a protective circuit works.

Indoor Lamp Indication for Trouble Shooting - RAV Series

Check Code List (Indoor)

○ : Go on, ◎ : Flash, ● : Go off ALT (Alternate): Alternate flashing when there are two flashing LED SIM (Simultaneous): Simultaneous flashing when there are two flashing LED

(Indoor unit detected)

Check code indication	Indoor Sensor lamp indication				Representative defective position	Explanation of error contents	Air conditioner operation	
	Block indication						Automatic reset	Operation continuation
TCC-LINK central & Wired remote controller	Operation	Timer	Ready	Flash				
E03	◎	●	●		Regular communication error between indoor and remote controller	No communication from remote controller and network adapter (Also no communication from central control system)	○	×
E04	●	●	◎		Indoor/Outdoor serial error	There is error on serial communication between indoor and outdoor units	○	×
E08	◎	●	●		Duplicated indoor addresses	Same address as yours was detected.	○	×
E10	◎	●	●		Communication error between indoor MCU	MCU communication error between main motor and micro computer	○	×
E18	◎	●	●		Regular communication error between indoor master and follower units	Regular communication between indoor master and follower units is impossible, Communication between twin master (main) and follower (sub) units is impossible.	○	×
F01	◎	◎	●	ALT	Indoor unit, Heat exchanger (TCJ) error	Open/short was detected on heat exchanger (TCJ).	○	×
F02	◎	◎	●	ALT	Indoor unit, Heat exchanger (TC) error	Open/short was detected on heat exchanger (TC).	○	×
F10	◎	◎	●	ALT	Indoor unit, Room temp. sensor (TA) error	Open/short was detected on room temp. sensor (TA).	○	×
F29	◎	◎	●	SIM	Indoor unit, other indoor P.C. board error	EEPROM error (Other error may be detected. If no error, automatic address is repeated.	×	×
L03	◎	●	◎	SIM	Duplicated setting of indoor group master unit	There are multiple master units in a group.	×	×
L07	◎	●	◎	SIM	There is group cable in individual indoor unit.	When even one group connection indoor unit exists in individual indoor unit.	×	×
L08	◎	●	◎	SIM	Unset indoor group address	Indoor group address is unset.	×	×
L09	◎	●	◎	SIM	Unset indoor capacity	Capacity of indoor unit is unset.	×	×
L20	◎	○	◎	SIM	Duplicated central control system address	Duplicated setting of central control system address	○	×
L30	◎	○	◎	SIM	Outside error input to indoor unit (Interlock)	Abnormal stop by outside error (CN80) input	×	×
P01	●	◎	◎	ALT	Indoor unit, AC fan error	An error of indoor AC fan was detected. (Fan motor thermal relay worked.)	×	×
P10	●	◎	◎	ALT	Indoor unit, overflow detection	Float switch worked.	×	×
P12	●	◎	◎	ALT	Indoor unit, DC fan error	Indoor DC fan error (Over-current/Lock, etc.) was detected.	×	×
P19	◎	●	◎	ALT	4-way valve system error	In heating operation, an error was detected by temp. down of indoor heat exchanger sensor.	○	×
P31	◎	●	◎	ALT	Other indoor unit error	Follower unit in group cannot operate by warning from [E03/L03/L07/L08] of master unit.	○	×

◇ When this warning was detected before group construction/address check finish at power supply was turned on, the mode shifts automatically to AUTO address setup mode.

(Remote controller detected)

Check code indication	Indoor Sensor lamp indication				Representative defective position	Explanation of error contents	Air conditioner operation	
	Block indication						Automatic reset	Operation continuation
Wired remote controller	Operation	Timer	Ready	Flash				
E01	◎	●	●		No master remote controller, Remote controller communication (Receive) error	Signal cannot be received from indoor unit. Master remote controller was not set. (including 2 remote controllers)	—	—
E02	◎	●	●		Remote controller communication (Send) error	Signal cannot be sent to indoor unit.	—	—
E09	◎	●	●		Duplicated master remote controller	In 2-remote controller control, both were set as master. (Indoor master unit stops warning and follower unit continues operation.)	×	△

(Central control devices detected)

Check code indication	Indoor Sensor lamp indication				Representative defective position	Explanation of error contents	Air conditioner operation	
	Block indication						Automatic reset	Operation continuation
TCC-LINK central	Operation	Timer	Ready	Flash				
C05	Is not displayed. (Common use of remote controller, etc.)				Central control system communication (send) error	Signal sending operation of central control system is impossible. There are multiple same central devices. (AI-NET)	—	—
C06					Central control system communication (receive) error	Signal receiving operation of central control system is impossible.	—	—
C12	—				General-purpose device control interface batched warning	An error on device connected to general-purpose device control interface of exclusive to TCC-LINK/AI-NET	—	—
P30	By warning unit (Above-mentioned)				Group follower unit is defective.	Group follower unit is defective. (For remote controller, above-mentioned [***] details are displayed with unit No.	—	—

NOTE: Even for the same contents of error such as communication error, the display of check code may differ according to detection device. When remote controller or central controller detects an error, it is not necessarily related to operation of the air conditioner. In this list, the check codes that outdoor unit detects are not described.

Indoor Lamp Indication for Trouble Shooting - RAV Series

Check Code List (Outdoor)

○ : Go on, ◎ : Flash, ● : Go off

ALT (Alternate): Alternate flashing when there are two flashing LED SIM (Simultaneous): Simultaneous flashing when there are two flashing LED

Remote controller indication	Indoor Sensor lamp part			Representative defective position	Detection	Explanation of error contents	Automatic reset	Operation continuation	
	Block indication								
	Operation	Timer	Ready	Flash					
F04	◎	◎	○	ALT	Outdoor unit Discharge temp. sensor (TD) error	Outdoor	Open/Short of discharge temp. sensor was detected.	✗	✗
F06	◎	◎	○	ALT	Outdoor unit Temp. sensor (TE, TS, TL) error	Outdoor	Open/Short of heat exchanger temp. sensor was detected. Miswiring between TE sensor and TS sensor	✗	✗
F08	◎	◎	○	ALT	Outdoor unit Outside temp. sensor (TO) error	Outdoor	Open/Short of outside temp. sensor was detected.	○	○
F07	◎	◎	○	ALT	Outdoor unit Temp. sensor (TL) error	Outdoor	Open/Short of heat exchanger temp. sensor was detected.	✗	✗
F12	◎	◎	○	ALT	Outdoor unit Temp. sensor (TS) error	Outdoor	Open/Short of suction temp. sensor was detected.	✗	✗
F13	◎	◎	○	ALT	Outdoor unit Temp. sensor (TH) error	Outdoor	Open/Short of heat sink temp. sensor (Board installed) was detected.	✗	✗
F15	◎	◎	○	ALT	Outdoor unit Misconnection of temp. sensor (TE, TS)	Outdoor	Misconnection of outdoor heat exchanger temp. sensor and suction temp. sensor was detected.	✗	✗
F31	◎	◎	○	SIM	Outdoor unit EEPROM error	Outdoor	Outdoor PC. board part (EEPROM) error was detected.	✗	✗
H01	●	◎	●		Outdoor unit Compressor break down	Outdoor	When reached min-Hz by current release control, short-circuited current (Idc) after DC excitation was detected.	✗	✗
H02	●	◎	●		Outdoor unit Compressor lock	Outdoor	Compressor lock was detected.	✗	✗
H03	●	◎	●		Outdoor unit Current detection circuit error	Outdoor	Current detection circuit error	✗	✗
H04	●	◎	●		Outdoor unit Case thermostat operation	Outdoor	Case thermostat operation was detected.	✗	✗
L10	◎	○	◎	SIM	Outdoor unit Setting error of service PC. board type	Outdoor	When outdoor service PC. board was used, model type select jumper setting was inappropriate.	✗	✗
L29	◎	○	◎	SIM	Outdoor unit Other outdoor unit error	Outdoor	1) Defective parts on outdoor PC. board (MCU communication, EEPROM, TH sensor error) 2) When outdoor service PC. board was used, model type selection was inappropriate. 3) Other error (Heat sink abnormal overhear, gas leak, 4-way valve inverse error) was detected.	✗	✗
P03	◎	●	◎	ALT	Outdoor unit Discharge temp. error	Outdoor	Error was detected by discharge temp. release control.	✗	✗
P04	◎	●	◎	ALT	Outdoor unit High pressure system error, Power supply voltage error	Outdoor	When case thermostat worked, error was detected by high release control from indoor/ outdoor heat exchanger temp. sensor. Power supply voltage error	✗	✗
P05	◎	●	◎	ALT	Power supply error	Outdoor	Power supply voltage error	✗	✗
P07	◎	●	◎	ALT	Outdoor unit Heat sink overheat	Outdoor	Abnormal overheat was detected by outdoor heat sink temp. sensor.	✗	✗
P15	◎	●	◎	ALT	Gas leak detection	Outdoor	Abnormal overheat of discharge temp. or suction temp. was detected.	✗	✗
P20	◎	●	◎	ALT	Outdoor unit High pressure system error	Outdoor	Error was detected by high release control from indoor/outdoor heat exchanger temp. sensor.	✗	✗
P22	◎	●	◎	ALT	Outdoor unit Outdoor fan error	Outdoor	Error (Over-current, lock, etc.) was detected on outdoor fan drive circuit.	✗	✗
P26	◎	●	◎	ALT	Outdoor unit Inverter Idc operation	Outdoor	Short-circuited protective operation of compressor drive circuit element (G-Tr /IGBT) worked.	✗	✗
P29	◎	●	◎	ALT	Outdoor unit Position detection error	Outdoor	Position detection error of compressor motor was detected.	✗	✗
E01	◎	●	●		No remote controller master unit Remote controller communication error	Remote controller	Signal was not received from indoor unit. Main remote controller was not set. (including 2 remote controllers)	—	—
E02	◎	●	●		Remote controller send error	Remote controller	Signal cannot be sent to indoor unit.	—	—
E03	◎	●	●		Regular communication error between indoor and remote controller	Indoor	No communication from remote controller and network adapter	○	✗
E04	●	●	◎		Indoor/Outdoor serial error	Indoor	Serial communication error between indoor and outdoor	○	✗
E08	◎	●	●		Duplicated indoor addresses	Indoor	Same address as yours was detected.	○	—
E09	◎	●	●		Duplicated main remote controllers	Remote controller	In 2-remote controller control, both were set as master. (Indoor master unit stops warning and follower unit continues operation.)	✗	✗
E10	◎	●	●		Communication error between CPU	Indoor	MCU communication error between main motor and micro computer	○	△
E18	◎	●	●		Regular communication error between master and follower indoor units	Indoor	Regular communication was impossible between master and follower indoor units. Communication between twin master (Main unit) and follower (sub unit) was impossible.	○	✗
L03	◎	●	◎	SIM	Duplicated indoor master units	Indoor	There are multiple master units in a group.	✗	✗
L07	◎	●	◎	SIM	There is group cable in individual indoor unit.	Indoor	When even one group connection indoor unit exists in individual indoor unit	✗	✗
L08	◎	●	◎	SIM	Unset indoor group address	Indoor	Indoor address group was unset.	✗	✗
L09	◎	●	◎	SIM	Unset indoor capacity	Indoor	Capacity of indoor unit was unset.	✗	✗
L30	◎	○	◎	SIM	Outside error input to indoor unit (Interlock)	Indoor	Abnormal stop by CN80 outside error input	✗	✗
P19	◎	●	◎	ALT	4-way valve inverse error	Indoor Outdoor	In heating operation, error was detected by temp. down of indoor heat exchanger or temp. up of TE, TS.	○	✗

◇ When this warning was detected before group construction/address check finish at power supply was turned on, the mode shifts automatically to AUTO address setup mode.

Indoor Lamp Indication for Trouble Shooting - RAV Series

○ : Go on, ◎ : Flash, ● : Go off

ALT (Alternate): Alternate flashing when there are two flashing LED SIM (Simultaneous): Simultaneous flashing when there are two flashing LED

Remote controller indication	Indoor Sensor lamp part				Representative defective position	Detection	Explanation of error contents	Automatic reset	Operation continuation
	Block indication								
	Operation	Timer	Ready	Flash					
F01	◎	◎	●	ALT	Indoor unit Heat exchanger sensor (TCJ) error	Indoor	Open/Short of heat exchanger (TCJ) was detected.	○	✗
F02	◎	◎	●	ALT	Indoor unit Heat exchanger sensor (TC) error	Indoor	Open/Short of heat exchanger (TC) was detected.	○	✗
F10	◎	◎	●	ALT	Indoor unit Room temp. sensor (TA) error	Indoor	Open/Short of room temp. (TA) was detected.	○	✗
F29	◎	◎	◎	SIM	Indoor unit Other indoor P.C. board error	Indoor	EEPROM error (Other error may be detected. If no error, automatic address is repeated.	✗	✗
P01	●	◎	◎	ALT	Indoor unit Indoor fan error	Indoor	Indoor AC fan error was detected. (Fan thermal relay worked.)	✗	✗
P10	●	◎	◎	ALT	Indoor unit Overflow detection	Indoor	Float switch worked.	✗	✗
P12	●	◎	◎	ALT	Indoor unit Indoor fan error	Indoor	Indoor fan error (Over-current / Lock, etc.) was detected.	✗	✗
P31	◎	●	◎	ALT	Other indoor unit error	Indoor	Other indoor under condition of warning in group. E03/L07/L03/L08 warning	○	✗
—	By unit with warning No.				ALT	Error in indoor group	Network adapter	Sub remote controller error in a group (Details of remote controller are displayed with unit No. Only central control side is displayed.)	
—	—				—	LAN system communication error	Network adapter/Center	Communication error of central control system signal ※ Is not displayed on the remote controller	
L20	◎	○	◎	SIM	LAN system communication error	Network adapter/Center	Duplicated indoor address of central control system communication		
—	—				—	There are multiple communication adapters.	Network adapter	There are multiple communication adapters on remote controller communication line.	

Apps Store Fault Codes – All Commercial & VRF Systems

Download **Toshiba Fault Codes** from your Apps Store or go to web page Toshiba-calc.co.uk/fault-codes/

Example: 1

Local controller displaying fault code **E04**
Enter **E04** and select **Find Fault**

VRF fault codes can be model specific and may require condenser model reference in Fault Code

Example: 2

Local controller displaying fault code **L29**
Condenser displaying sub-code **07**
Model of condenser **MMY-MAP1604HT8-E**
Enter **L29071604** and select **Find Fault**

Please note; codes can be entered with or without character spaces, spaces ignored in text strings.

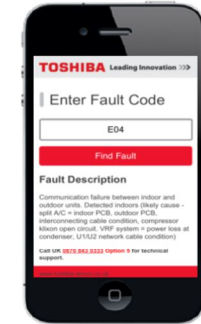
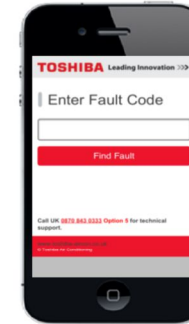

Fault code diagnosis apps now available
For
Apple iPhone & Android



Fault Codes – All Commercial & VRF Systems

Do Not turn off the power supply before reading the fault codes, doing so will clear the diagnostic memory.

Caution must be taken when removing the access covers, as high voltages are present.

Fault diagnosis is available at three locations within the Air Conditioning system. :-

- | | |
|--|--|
| 1 Remote Controller - press the check button | 2 Multi Controller - rotate the display switch to position 1 |
| 3 Central Controller - press the check button (if installed) | 4 Outdoor Unit Switch position (variable dependent upon model): – |
| | 2 Pipe Super Multi 2, 3 & 8; 3 Pipe Super Multi 2 & 0; |
| | 3 Pipe SMI 2 & 0 2 Pipe Modular Multi MMY 1, 1, 1 |
| | 3 Pipe Modular Multi MMY 1, 1, 1 |

Code	Fault Description
04	Split A/C equipment indoor to outdoor communication failure / VRF equipment could also be attributed to communication breakdown between condenser PCB's. Likely cause Indoor PCB / condenser PCB / Interconnecting cable damage / transformer used to power condenser PCB
08	Reverse change in temperature. Detected by indoor evaporator sensor (TC). Likely cause 4-way valve. 4 way reversing valve energised for heating operation only
09	Frost conditions detected / No temperature change. Detected indoors by evaporator sensor (TC). Likely cause poor airflow, lack of refrigerant, overheating compressor
11	Indoor fan trouble. Detected indoors. Likely cause fan motor, PCB
12	EEPROM Failure on PCB. Detected indoors (replace indoor PCB)
14	Inverter compressor PCB short circuit. Detected at outdoor. Likely cause blown fuses supplying inverter pack, faulty IPDU(inverter board) or component within inverter pack, electrical fault on inverter compressor
15	Multi-Control box error. Detected indoors (interrogate Multi-Control box for additional faults by setting display switch @ position 1)
17	Abnormal current detection on inverter compressor. Detected at outdoor. (replace IPDU PCB (inverter board))
18	Condenser coil sensor fault. Detected indoors. Likely cause TE/TE1 sensor condition or outdoor PCB fault sensor value 20°C=12.5k ohms
19	Liquid or compressor discharge sensor fault. Likely cause TL, TD sensor condition or PCB fault TL sensor value 20°C=12.5k ohms TD sensor value 20°C=63k ohms
20	Condenser PCB faulty (replace main PCB)
21	2 pipe VRF & Split A/C equipment High Pressure switch activation 425psi-29bar _ 3 pipe VRF equipment, interrogate condenser PCB for additional fault code. Detected at outdoor. Likely cause split A/C equipment fault HP Switch, restriction in refrigerant flow, fan motor failure, poor airflows / VRF equipment set condenser interface PCB switches as follows SW1 @ position 2 & SW2 @ position 0 (see sub codes Er21 or ErAd)
22	Excessive high pressure. Detected at outdoor. Likely cause abnormal characteristics of Pd transducer, refrigerant restriction/blockage
80	Multi-Control box Th(A) sensor fault. Likely cause TH(A) sensor or M/C box PCB sensor value 20°C=12.5k ohms
81	Multi-Control box Th(B) sensor fault. Likely cause TH(B) sensor or M/C box PCB sensor value 20°C=12.5k ohms
82	Multi-Control box Th(C) sensor fault. Likely cause TH(C) sensor or M/C box PCB sensor value 20°C=12.5k ohms
83	Multi-Control box Th(D) sensor fault. Likely cause TH(D) sensor or M/C box PCB sensor value 20°C=12.5k ohms
84	Multi-Control box Th(X) sensor fault. Likely cause TH(X) sensor or M/C box PCB sensor value 20°C=12.5k ohms

Code	Fault Description
87	Phase missing phase. Detected at outdoor. Likely cause abnormal power supply
88	Multi-Control box does not recognise condenser capacity. Likely cause interconnecting cable damage, outdoor PCB fault
89	Indoor capacity too high. Likely cause loss of combination within group of modularised condensers
93	Indoor coil sensor fault. Detected indoors. Likely cause TC1 sensor condition or indoor PCB fault sensor value 20°C=12.5k ohms
94	Indoor coil sensor fault. Detected indoors. Likely cause TC2 sensor condition or indoor PCB fault sensor value 20°C=12.5k ohms
95	Communication failure on P&Q network (indoor/outdoor communication). Detected indoors & outdoors. Likely cause network cable condition, PCB failure indoor or outdoor
96	Indoor unit count too high. Detected at outdoor. Likely cause indoor capacity vs. outdoor capacity Incorrect, too many indoor units connected
97	Central control communication error. Detected at central controller & indoors. Likely cause indoor power failure, central address error, cable damage
98	Duplicated zone address. Likely cause incorrectly assigned central control addresses
99	No communication from indoor to remote controller. Detected by hard-wired remote controller. Likely cause faulty indoor PCB, remote controller or cable damage
0b	Indoor float switch open circuit as result of high condensation levels within drip tray. Detected indoors. Likely cause faulty float switch, faulty lift pump, debris blocking drain
0c	Return air sensor fault. Detected indoors. Likely cause TA sensor condition or indoor PCB fault sensor value 20°C=12.5k ohms
0d	Coil sensor fault. Detected indoors. Likely cause TC sensor condition or indoor PCB fault sensor value 20°C=12.5k ohms
1C	Outdoor error. Detected indoors (interrogate condenser for additional faults)
1d	High Inverter dc current. Detected at outdoor. Likely cause imbalance in compressor voltage, excessive amps by inverter compressor
1E	High compressor discharge temperature. Detected at outdoor. Likely cause low refrigerant, poor refrigerant flow, poor airflows, TD sensor condition sensor value 20°C=63k ohms
1F	High Inverter ac current. Detected at outdoor. Likely cause imbalance in compressor voltage, excessive amps by inverter compressor
8d	Outdoor unit quantity fallen (loss of communication between condensers). Detected at outdoor. Likely cause power interruption, BUS communication cable condition
8E	Outdoor unit's quantity too high. Detected at outdoor. Likely cause too many condensers connected
8F	Outdoor unit address incorrect. Detected at outdoor. Likely cause multiple modularised condenser having SW 9 ON, Interface PCB failure
9A	No temperature change on evaporator. Detected by indoor evaporator sensor TC1. Likely cause miss-wiring, restriction in refrigerant flow, lack of refrigerant
9F	Insufficient temperature change on evaporator. Detected indoors. Likely cause miss-wiring, restriction in refrigerant flow, lack of refrigerant, TC1, TC2 & TA sensor condition sensor value 20°C=12.5k ohms
A0	Compressor discharge sensor fault. Detected at outdoor. Likely cause TD1/ThD1 sensor condition or Interface PCB sensor value 20°C=63k ohms
A1	High compressor discharge temperature. Detected at outdoor. by TD1. Likely cause low refrigerant, poor refrigerant flow and airflows & TD2 sensor condition sensor value 20°C=63k ohms
A2	Compressor suction sensor fault. Detected at outdoor. Likely cause TS1/ThS sensor condition or interface PCB sensor value 20°C=12.5k ohms
A6	High compressor suction temperature > 40°C. Detected at outdoor. Likely cause severe gas shortage, TS sensor condition, interface PCB sensor value 20°C=12.5k ohms
A7	High compressor suction temperature > 40°C. Detected at outdoor. Likely cause severe gas shortage, TS sensor condition, interface PCB sensor value 20°C=12.5k ohms

Code	Fault Description
AA	High side pressure sensor fault. Detected at outdoor. (Replace Pd pressure transducer)
Ab	Pressure transducer error. Detected at outdoor. Likely cause abnormal running pressures, abnormal PS / Pd characteristics, interface PCB
AE	High compressor discharge temperature @ low inverter speed. Detected at outdoor. Likely cause TD1 sensor condition, insufficient refrigerant sensor value 20°C=63k ohms
AF	Phase rotation incorrect. Detected at outdoor. Likely cause abnormal phase order, missing phase to outdoor unit
b4	Low pressure transducer error or misreading fault. Detected at outdoor. Likely cause incorrect characteristics of suction pressure transducer (PS, interface PCB faulty)
b5	External input activation, refrigerant leak detection system (Call Toshiba's technical helpline for further details 0870 843 0333)
b6	External input activation, refrigerant leak detection system (Call Toshiba's technical helpline for further details 0870 843 0333)
b7	Indoor group follower error. Detected at central controller (interrogate local controller by pressing check for additional fault codes)
b9	Pressure sensor fault. Detected indoors. Likely cause evaporator pressure sensor unplugged, pressure sensor open circuit replace sensor
bb	High compressor discharge temperature. Detected at outdoor. by TD2. Likely cause low refrigerant, poor refrigerant flow and airflows & TD2 sensor condition sensor value 20°C=63k ohms
bE	Low pressure trip. Detected outdoor by PS transducer. Likely cause suction pressure transducer condition (PS), interface PCB fault restriction in refrigerant flow, lack of refrigerant
C05	Command sending error. Detected on Central Controller. Likely cause power loss at indoor unit group, network cable condition)
C06	Command receiving error. Detected on Central Controller. Likely cause power loss at indoor unit group, network cable condition)
d1	Master condenser setup alarm. Detected at outdoor. Likely cause multiple inverter outdoor units connected, faulty interface PCB)
d2	Fault within follower condenser. Detected at outdoor. (retrieve additional fault code from follower condensers)
d3	IPDU PCB overheat (inverter board). Detected at outdoor. Likely cause clogged heat-sink fins, poorly secured or faulty IPDU PCB)
d4	Oil sensor fault. Detected at outdoor. Likely cause TK1 sensor condition or outdoor PCB fault sensor value 20°C=63k ohms)
d5	Oil sensor fault. Detected at outdoor. Likely cause TK2 sensor condition or outdoor PCB fault sensor value 20°C=63k ohms)
d6	Oil sensor fault. Detected at outdoor. Likely cause TK3 sensor condition or outdoor PCB fault sensor value 20°C=63k ohms)
d7	Low oil detection. Detected at outdoor. Likely cause TK1, TK2 & TK3 sensor condition, interface PCB, lack of refrigerant sensor value 20°C=63k ohms)
d8	Oil temperature alarm. Detected at outdoor. Likely cause TK1 sensor location or condition, outdoor PCB fault sensor value 20°C=63k ohms
d9	Oil temperature alarm. Detected at outdoor. Likely cause TK2 sensor location or condition, outdoor PCB fault sensor value 20°C=63k ohms
dA	Abnormal overheat of heat-sink. Detected at outdoor. Likely cause clogged heat-sink fins, poorly secured or faulty IPDU board
db	No oil flow detected. Detected at outdoor. Likely cause TK1, TK2 & TK3 sensor location or condition, interface PCB, blockage within SV3C sensor value 20°C=63k ohms
dC	High temperature oil alarm. Detected at outdoor. Likely cause TK1 sensor condition, interface PCB fault, high ambient running conditions >43°C sensor value 20°C=63k ohms
dd	Temperature change when condensers in off cycle. Detected at outdoor. Likely cause PMV passing within condenser, discharge & suction pressure transducer error (PS & Pd characteristics), interface PCB fault
dE	Indoor unit automatic addressing failure. Detected at outdoor. Likely cause indoor PCB configuration error, indoor PCB faulty
dF	Outdoor unit automatic address failure. Detected at outdoor. Likely cause interface PCB fault

Code	Fault Description
E01	Communication error between indoor unit and remote controller. Detected by remote controller. Likely cause indoor PCB, remote controller, incorrect switch position on rear of remote controller, all switches normally down
E02	Sending error of local remote controller. Detected by remote controller. Likely cause replace remote controller
E03	Communication error between indoor unit and central remote controller. Detected indoors. Likely cause indoor network adapter, central remote controller
E04	Communication failure between indoor and outdoor units. Detected indoors. Likely cause split A/C=indoor PCB, outdoor PCB, interconnecting cable condition, compressor klixon open circuit. VRF system=power loss at condenser, U1/U2 network cable condition
E06	Decrease in quantity of indoor units. Detected indoors. Likely cause power loss at indoor unit, indoor PCB fault, A&B controller cable condition
E07	Communication failure between indoor and outdoor units. Detected at outdoor. Likely cause interconnecting cable condition, outdoor PCB switch position SW30 bit 1 & 2 must be placed in ON position for test
E08	Duplicated indoor address. Detected indoors. Likely cause incorrect setting of BUS addresses when under central control
E09	Duplicated master remote controllers. Detected indoors. Likely cause two local remote controller connected on A&B network
E1	Activation of high-pressure switch on D.O.L (Fixed speed) compressor 1. Detected at outdoor. Likely cause fan motor trouble, poor airflows, restricted refrigerant flow
e1 80	Multi-Control box 1 Th(A) sensor fault. Likely cause TH(A) sensor or M/C box PCB sensor value 20°C=12.5k ohms
e1 81	Multi-Control box 1 Th(B) sensor fault. Likely cause TH(B) sensor or M/C box PCB sensor value 20°C=12.5k ohms
e1 82	Multi-Control box 1 Th(C) sensor fault. Likely cause TH(C) sensor or M/C box PCB sensor value 20°C=12.5k ohms
e1 83	Multi-Control box 1 Th(D) sensor fault. Likely cause TH(D) sensor or M/C box PCB sensor value 20°C=12.5k ohms
e1 84	Multi-Control box 1 Th(X) sensor fault. Likely cause TH(X) sensor or M/C box PCB sensor value 20°C=12.5k ohms
E10	Communication Error at indoor PCB. Detected indoors. Likely cause replace indoor PCB
E12	Automatic addressing error. Detected at outdoor. Likely cause incorrect self-addressing sequence, repeat self-addressing procedure. Retrieve fault sub- code from condenser interface PCB by placing rotary dials to position 1 / 1 / 1 for diagnosis.
E12 01	Automatic addressing error. Detected at outdoor. Indoor / Outdoor communication
E12 02	Automatic addressing error. Detected at outdoor. Outdoor / Outdoor communication
E15	Automatic self-addressing failure. Detected at outdoor. Likely cause SW30 bit 1 & 2 in OFF position, switch both ON before self-addressing commenced, interface PCB failure
E16	Indoor unit count or capacity to high. Detected at outdoor. Likely cause if condenser PCB displays sub code 00=indoor capacity vs. condenser to high. If sub code at condenser reads 01=indoor unit count/quantity to high. Retrieve fault sub-code from condenser interface PCB by placing rotary dials to position 1 / 1 / 1 for diagnosis.
E16 00	Indoor unit capacity to high. Detected at outdoor. Likely cause indoor unit capacity to high vs. condenser capacity
E16 01	Indoor unit count to high. Detected at outdoor. Likely cause indoor unit count to high vs. outdoor upper limit
E18	Communication failure between indoor units. Detected indoors. Likely cause indoor power loss, A&B controller cable condition. Twin, triple & Quad applications E18 can result from E04 fault code
E19	Outdoor header error. Detected at outdoor. Likely cause if condenser PCB displays sub code 00=power loss to indoor units or U1/U2 network cable condition. If sub code reads 01=incorrect wiring between modularised condensers. Retrieve fault sub-code from condenser interface PCB by placing rotary dials to position 1 / 1 / 1 for diagnosis.

Code	Fault Description
E19 00	Outdoor header error. Detected at outdoor. Likely cause power loss to indoor units, U1/U2 network cable condition, SW30 bit 1 & 2 must be ON to test
E19 01	Outdoor header error. Detected at outdoor. Likely cause incorrect wiring between modularised condensers
e2 80	Multi-Control box 2 Th(A) sensor fault. Likely cause TH(A) sensor or M/C box PCB sensor value 20°C=12.5k ohms
e2 81	Multi-Control box 2 Th(B) sensor fault. Likely cause TH(B) sensor or M/C box PCB sensor value 20°C=12.5k ohms
e2 82	Multi-Control box 2 Th(C) sensor fault. Likely cause TH(C) sensor or M/C box PCB sensor value 20°C=12.5k ohms
e2 83	Multi-Control box 2 Th(D) sensor fault. Likely cause TH(D) sensor or M/C box PCB sensor value 20°C=12.5k ohms
e2 84	Multi-Control box 2 Th(X) sensor fault. Likely cause TH(X) sensor or M/C box PCB sensor value 20°C=12.5k ohms
E20	One or more systems connected on network during self-addressing procedure. Detected at outdoor. Likely cause if condenser PCB displays sub code 01=multiple outdoor systems connected on U3/U4 network, miss-wiring or central control relay connector in-place. If sub code reads 02=indoor units from other line connected, miss-wiring or central control relay connector in-place. Retrieve fault sub-code from condenser interface PCB by placing rotary dials to position 1 / 1 / 1 for diagnosis.
E20 01	Multiple indoor system line numbers connected on network during self-addressing procedure. Detected at outdoor. Likely cause miss-wiring of indoor network cable, central control relay connector together during self-address
E20 02	Multiple outdoor system numbers connected on network during self-address procedure. Detected at outdoor. Likely cause miss-wiring of outdoor units, central control relay/plug connected during self-address
E23	Communication error between outdoor units. Detect outdoors. Likely cause U5/U6 cable condition, interface PCB fault
E25	Duplicated follower outdoor unit address. Detected at outdoor. Likely cause error in manually assigning addresses, allow system to self-address
E26	Decrease in quantity of outdoor units connected. Detected at outdoor. Likely cause power loss at condensers, U5/U6 cable condition
E28	Outdoor follower fault. Detected at outdoor. Likely cause lead condenser OK, follower condenser has suffered fault, retrieve second fault code from follower condenser
E31	IPDU/PCB board communication error. Detected at outdoor. Likely cause loss in communication between condenser PCB's. Retrieve fault sub-code from condenser interface PCB by placing rotary dials to position 1 / 1 / 1 for diagnosis.
E31 01	Compressor 1 IPDU board communication error. Detected at outdoor. Likely cause check communication cable linking all PCB's, replace Compressor 1 IPDU board
E31 02	Compressor 2 IPDU board communication error. Detected at outdoor. Likely cause check communication cable linking all PCB's, replace Compressor 2 IPDU board
E31 03	Compressor 1 & 2 IPDU board communication error. Detected at outdoor. Likely cause check communication cable linking all PCB's, replace Compressor 1 & 2 IPDU board
E31 04	Communication failure between PCB's within condenser. Detected at outdoor. Fault Code is outdoor model series specific e.g. MMY-MAP###1HT8-E, MMY-AP###2HT8-E or MMY-MAP###4HT8-E therefore example fault code for E3104 will be (MMY-MAP0801HT8-E (series 1), MMY-MAP0802HT8-E (series 2), MMY-MAP0804HT8-E (series 4) search E31041, E31042 or E31044
E31 04 1	Fan IPDU board communication error. Detected at outdoor. Likely cause check communication cable linking all PCB's, replace fan IPDU board
E31 04 2	Fan IPDU board communication error. Detected at outdoor. Likely cause check communication cable linking all PCB's, replace fan IPDU board
E31 04 4	Compressor 3 IPDU board communication error. Detected at outdoor. Likely cause check communication cable linking all PCB's, replace Compressor 3 IPDU board

Code	Fault Description
E31 05	Communication failure between PCB within condenser. Fault Code is outdoor model series specific e.g. MMY-MAP###1HT8-E, MMY-AP###2HT8-E or MMY-MAP###4HT8-E therefore example fault code for E3105 will be (MMY-MAP0801HT8-E (series 1), MMY-MAP0802HT8-E (series 2), MMY-MAP0804HT8-E (series 4) search E31051, E31052 or E31054
E31 05 1	Compressor 1 IPDU & fan IPDU board communication error. Detected at outdoor. Likely cause check communication cable linking all PCB's, replace Compressor 1 IPDU & fan IPDU board
E31 05 2	Compressor 1 IPDU & fan IPDU board communication error. Detected at outdoor. Likely cause check communication cable linking all PCB's, replace Compressor 1 IPDU & fan IPDU board
E31 05 4	Compressor 1 & 3 IPDU board communication error. Detected at outdoor. Likely cause check communication cable linking all PCB's, replace Compressor 1 & 3 IPDU board
E31 06	Communication failure between PCB within condenser. Detected at outdoor. Fault Code is outdoor model series specific e.g. MMY-MAP###1HT8-E, MMY-AP###2HT8-E or MMY-MAP###4HT8-E therefore example fault code for E3106 will be (MMY-MAP0801HT8-E (series 1), MMY-MAP0802HT8-E (series 2), MMY-MAP0804HT8-E (series 4) search E3101, E31062 or E31064
E31 06 1	Compressor 2 IPDU & fan IPDU board communication error. Detected at outdoor. Likely cause check communication cable linking all PCB's, replace Compressor 2 IPDU & fan IPDU board
E31 06 2	Compressor 2 IPDU & fan IPDU board communication error. Detected at outdoor. Likely cause check communication cable linking all PCB's, replace Compressor 2 IPDU & fan IPDU board
E31 06 4	Compressor 2 & 3 IPDU board communication error. Detected at outdoor. Likely cause check communication cable linking all PCB's, replace Compressor 2 & 3 IPDU board
E31 07	Communication failure between PCB within condenser. Detected at outdoor. (4 Series Condenser Compressor 1, 2 & 3 IPDU board communication error). (1&2 Series condenser communication error between PCB within condenser) likely cause phase missing on power supply, replace interface PCB
E31 07 1	Communication error between PCB within condenser. Detected at outdoor. Likely cause check communication cable linking all PCB's, phase missing on power supply, replace interface PCB
E31 07 2	Communication error between PCB within condenser. Detected at outdoor. Likely cause check communication cable linking all PCB's, phase missing on power supply, replace interface PCB
E31 07 4	Compressor 1, 2 & 3 IPDU board communication error. Detected at outdoor. Likely cause check communication cable linking all PCB's, replace Compressor 1, 2 & 3 IPDU board
E31 08	Fan IPDU board communication error. Detected at outdoor. Likely cause check communication cable linking all PCB's, replace fan IPDU board
E31 09	Compressor 1 IPDU & fan IPDU board communication error. Detected at outdoor. Likely cause check communication cable linking all PCB's, replace Compressor 1 IPDU & fan IPDU board
E31 0A	Compressor 2 IPDU & fan IPDU board communication error. Detected at outdoor. Likely cause check communication cable linking all PCB's, replace Compressor 2 IPDU & fan IPDU board
E31 0B	Compressor 1 & 2 IPDU board & fan IPDU board communication error. Detected at outdoor. Likely cause check communication cable linking all PCB's, replace Compressor 1 & 2 IPDU PCB & fan IPDU board
E31 0C	Compressor 3 IPDU board & fan IPDU board communication error. Detected at outdoor. Likely cause check communication cable linking all PCB's, replace Compressor 3 IPDU board & fan IPDU board
E31 0d	Compressor 1 & 3 IPDU board & fan IPDU board communication error. Detected at outdoor. Likely cause check communication cable linking all PCB's, replace Compressor 1 & 3 IPDU board & fan IPDU board

Code	Fault Description
E31 0E	Compressor 2 & 3 IPDU board & fan IPDU board communication error. Detected at outdoor. Likely cause check communication cable linking all PCB's, replace Compressor 2 & 3 IPDU PCB & fan IPDU board
E31 0F	Communication error between PCB within condenser. Detected at outdoor. Likely cause check communication cable linking all PCB's, phase missing on power supply, replace interface PCB
E5	Activation of high-pressure switch or internal overheat (klixon on INVERTER compressor only. Detected at outdoor. Likely cause fan motor trouble, poor airflows, poor refrigerant flow, insufficient refrigerant
E6	Activation of compressor klixon or contactor overload on D.O.L (Fixed speed compressor 1. Detected at outdoor. Likely cause poor refrigerant flow, insufficient refrigerant, excessive amps by compressor
Eb	Resulting from b6 fault code generated at indoor unit. Detected at outdoor. (b6=External input activation, refrigerant leak detection system (Call Toshiba's technical helpline for further details 0870 843 0333)
Er 14	Inverter compressor low voltage. Detected at outdoor. Likely cause AC fuse disconnection, faulty component within compressor inverter circuit, electrical failure of compressor
Er 1d	High Inverter dc current. Detected at outdoor. Likely cause imbalance in compressor voltage, excessive amps by inverter compressor
Er 21	Inverter compressor trip. Detected at outdoor. Likely cause activation of high-pressure switch 425psi-29bar / internal overheat (klixon) on inverter compressor only
Er A0	Compressor discharge sensor fault. Detected at outdoor. Likely cause TD1/ThD1 sensor condition or Interface PCB sensor value 20°C=63k ohms
Er A1	Compressor discharge sensor fault. Detected at outdoor. Likely cause TD2/ThD2 sensor condition or Interface PCB sensor value 20°C=63k ohms
Er A2	Compressor suction sensor fault. Detected at outdoor. Likely cause TS1/ThS sensor condition or interface PCB sensor value 20°C=12.5k ohms
Er A4	Ambient air sensor fault. Detected at outdoor. Likely cause Th0 sensor condition or interface PCB sensor value 20°C=12.5k ohms
Er A5	Condenser coil sensor fault. Detected at outdoor. Likely cause ThE sensor condition or interface PCB fault sensor value 20°C=12.5k ohms
Er A6	High compressor discharge temperature. Detected at outdoor. by TD1, TD2, ThD1 & ThD2. Likely cause low refrigerant, poor refrigerant flow and airflows & TD sensor condition sensor value 20°C=63k ohms
Er A7	High compressor suction temperature > 40°C. Detected at outdoor. Likely cause severe gas shortage, TS sensor condition, interface PCB sensor value 20°C=12.5k ohms
Er AA	High side pressure sensor fault. Detected at outdoor. (Replace Pd pressure sensor)
Er Ad	Fixed speed compressor trip (D.O.L). Detected at outdoor. Likely cause activation of high-pressure switch 425psi-29bar / internal overheat (klixon) / phase rotation PCB / D.O.L contactor overload trip
Er AE	Low Pressure trip < 3 psig. Detected at outdoor. by L.P. switch. Likely cause refrigerant loss, restriction in refrigerant flow
Er AF	Phase rotation incorrect. Detected at outdoor. Likely cause abnormal phase order, missing phase to outdoor unit
F0	Activation of high pressure switch on D.O.L (Fixed speed) compressor 2. Detected at outdoor. Likely cause fan motor trouble, poor airflows, restricted refrigerant flow
F01	TCj Coil sensor fault. Detected indoors. Likely cause TCj sensor condition or indoor PCB fault sensor value 20°C=12.5k ohms
F02	TC2 or TC Coil sensor fault. Detected indoors. Likely cause TC2 / TC sensor condition or indoor PCB fault sensor value 20°C=12.5k ohms
F03	TC1 Coil sensor fault. Detected indoors. Likely cause TC1 sensor condition or indoor PCB fault sensor value 20°C=12.5k ohms

Code	Fault Description
F04	Td1 sensor fault. Detected at outdoor. Likely cause compressor discharge sensor condition (Td1) or outdoor PCB fault sensor value 20°C=63k ohms
F05	Td2 sensor fault. Detected at outdoor. Likely cause compressor discharge sensor condition (Td2) or outdoor PCB fault sensor value 20°C=63k ohms
F06	TE or TS Sensor fault. Detected at outdoor. Likely cause Heat exchange sensor condition (TE / TE1 / TE2). Suction line sensor condition (TS) or outdoor PCB fault sensor value 20°C=12.5k ohms. Retrieve fault sub-code from condenser interface PCB by placing rotary dials to position 1 / 1 / 1 for diagnosis.
F06 01	TE1 Sensor fault. Detected at outdoor. Likely cause Heat exchange sensor condition (TE1) or outdoor PCB fault sensor value 20°C=12.5k ohms
F06 02	TE2 Sensor fault. Detected at outdoor. Likely cause Heat exchange sensor condition (TE2) or outdoor PCB fault sensor value 20°C=12.5k ohms
F07	TL Sensor fault. Detected at outdoor. Likely cause Liquid line sensor condition (TL) or outdoor PCB fault sensor value 20°C=12.5k ohms
F08	TO Sensor fault. Detected at outdoor. Likely cause Ambient air sensor condition (TO) or outdoor PCB fault sensor value 20°C=12.5k ohms
F1	Activation of compressor klixon or contactor overload on D.O.L (Fixed speed compressor 2). Detected at outdoor. Likely cause poor refrigerant flow, insufficient refrigerant, excessive amps by compressor
F10	TA Sensor fault. Detected indoors. Likely cause Return air sensor condition (TA) or indoor PCB fault sensor value 20°C=12.5k ohms
F12	TS Sensor fault. Detected at outdoor. Likely cause Suction line sensor condition (TS / TS1 / TS2) or outdoor PCB fault sensor value 20°C=12.5k ohms
F13	Compressor IPDU board overheat. Detected at outdoor. Likely cause poor contact to heat-sink, IPDU board fault. Fault sub-code required to determine which board has suffered overheat 01=IPDU1 overheated 02=IPDU2 overheated 03=IPDU3 overheated. Retrieve fault sub-code from condenser interface PCB by placing rotary dials to position 1 / 1 / 1 for diagnosis.
F13 01	Compressor 1 IPDU board overheat. Detected at outdoor. Likely cause poor contact to heat-sink, replace compressor IPDU board 1
F13 02	Compressor 2 IPDU board overheat. Detected at outdoor. Likely cause poor contact to heat-sink, replace compressor IPDU board 2
F13 03	Compressor 3 IPDU board overheat. Detected at outdoor. Likely cause poor contact to heat-sink, replace compressor IPDU board 3
F15	Outdoor temperature sensor error. Detected at outdoor. Likely cause VRF equipment=Heat exchange (TE) sensor condition/location or Liquid line (TL) sensor condition/location, outdoor PCB fault Split equipment=Suction sensor (TS) condition/location Heat exchange sensor (TE) condition/location, outdoor PCB fault sensor value 20°C=12.5k ohms
F16	Pressure sensors miss-reading. Detected at outdoor. Likely cause incorrect characteristics of compressor discharge (Pd) & compressor suction (PS) pressure sensor or total loss of refrigerant
F22	Td3 sensor fault. Detected at outdoor. Likely cause compressor discharge sensor condition (Td3) or outdoor PCB fault sensor value 20°C=63k ohms
F23	Compressor suction pressure sensor fault. Detected at outdoor. Likely cause Suction transducer (PS) fault, outdoor PCB fault
F24	Compressor discharge pressure sensor fault. Detected at outdoor. Likely cause discharge transducer (Pd) fault, outdoor PCB fault
F29	Indoor PCB fault. Detected indoors. Likely cause replace indoor PCB
F31	Outdoor EEPROM Error. Detected at outdoor. Likely cause VRF equipment=power interruption, replace interface PCB Split equipment=replace condenser CDB board
H01	Excessive amps drawn by compressor. Detected at outdoor. Likely cause imbalance in voltage supplied from IPDU board to compressor, compressor lock / seizure. Retrieve sub-code for VRF from condenser to determine which compressor suffered failure 01=compressor1, 02=compressor2 & 03=compressor3. Retrieve fault sub-code from condenser interface PCB by placing rotary dials to position 1 / 1 / 1 for diagnosis.
H01 01	Excessive amps drawn by compressor 1. Detected at outdoor. Likely cause imbalance in voltage supplied to compressor 1 from inverter IPDU board 1, compressor 1 lock / seizure

Code	Fault Description
H01 02	Excessive amps drawn by compressor 2. Detected at outdoor. Likely cause imbalance in voltage supplied to compressor 2 from inverter IPDU board 2, compressor 2 lock / seizure
H01 03	Excessive amps drawn by compressor 3. Detected at outdoor. Likely cause imbalance in voltage supplied to compressor 3 from inverter IPDU board 3, compressor 3 lock / seizure
H02	High amps drawn by compressor on start-up. Detected at outdoor. Likely cause imbalance in voltage supplied to compressor from IPDU board, compressor locked / seized. For VRF fault sub-code required to determine which compressor suffered failure 01=compressor1 02=compressor2 03=compressor3. Retrieve fault sub-code from condenser interface PCB by placing rotary dials to position 1 / 1 / 1 for diagnosis.
H02 01	High amps drawn by compressor 1 on start-up. Detected at outdoor. Likely cause imbalance in voltage supplied to compressor 1 from IPDU board 1, compressor 1 locked / seized
H02 02	High amps drawn by compressor 2 on start-up. Detected at outdoor. Likely cause imbalance in voltage supplied to compressor 2 from IPDU board 2, compressor 2 locked / seized
H02 03	High amps drawn by compressor 3 on start-up. Detected at outdoor. Likely cause imbalance in voltage supplied to compressor 3 from IPDU board 3, compressor 3 locked / seized
H03	Current detected in compressor off cycle. Detected at outdoor. Likely cause replace compressor IPDU board. For VRF fault sub-code required to determine which compressor suffered failure 01=compressor1 02=compressor2 03=compressor3. Retrieve fault sub-code from condenser interface PCB by placing rotary dials to position 1 / 1 / 1 for diagnosis.
H03 01	Current detected in compressor off cycle. Detected at outdoor. Likely cause replace compressor IPDU board 1
H03 02	Current detected in compressor off cycle. Detected at outdoor. Likely cause replace compressor IPDU board 2
H03 03	Current detected in compressor off cycle. Detected at outdoor. Likely cause replace compressor IPDU board 3
H04	Compressor 1 over-heat. Detected at outdoor. Likely cause compressor klixon activation, loss of refrigerant, poor refrigerant flow reducing cooling effect to compressor
H05	Compressor discharge temperature does not increase while compressor 1 operates. Detected at outdoor. Likely cause compressor discharge sensor (Td1) condition / location, outdoor PCB fault sensor value 20°C=63k ohms
H06	Low pressure protection operation. Detected at outdoor. Likely cause characteristics of suction pressure transducer (PS), system pump-down, interface PCB fault)
H07	Abnormal oil level / temperature alarm. Detected outdoor. Likely cause oil balance service valve, refrigerant loss, oil sensor condition (TK1 / TK2 / TK3 / TK4 / TK5), interface board PCB fault sensor value 20°C=63k ohms)
H08	TK Oil sensor fault. Detected at outdoor. Likely cause oil sensor condition, outdoor PCB fault. Fault sub code required to determine which sensor (TK1 / TK2 / TK3 / TK4 / TK5 sensor value 20°C=63k ohms). Retrieve fault sub-code from condenser interface PCB by placing rotary dials to position 1 / 1 / 1 for diagnosis.
H08 01	TK1 Oil sensor fault. Detected at outdoor. Likely cause oil sensor condition (TK1), outdoor PCB fault sensor value 20°C=63k ohms
H08 02	TK2 Oil sensor fault. Detected at outdoor. Likely cause oil sensor condition (TK2), outdoor PCB fault sensor value 20°C=63k ohms
H08 03	TK3 Oil sensor fault. Detected at outdoor. Likely cause oil sensor condition (TK3), outdoor PCB fault sensor value 20°C=63k ohms
H08 04	TK4 Oil sensor fault. Detected at outdoor. Likely cause oil sensor condition (TK4), outdoor PCB fault sensor value 20°C=63k ohms
H08 05	TK5 Oil sensor fault. Detected at outdoor. Likely cause oil sensor condition (TK5), outdoor PCB fault sensor value 20°C=63k ohms
H14	Compressor 2 over-heat. Detected at outdoor. Likely cause compressor klixon activation, loss of refrigerant, poor refrigerant flow reducing cooling effect to compressor

Code	Fault Description
H15	Compressor discharge temperature does not increase while compressor 2 operates. Detected at outdoor. Likely cause compressor discharge sensor (Td2) condition / location, outdoor PCB fault sensor value 20°C=63k ohms
H16	TK oil sensors do not detect temperature change while compressors operate. Detected at outdoor. Likely cause oil line (TK1 / TK2 / TK3 / TK4 / TK5) sensor condition / location, outdoor PCB fault sensor value 20°C=63k ohms. Retrieve fault sub-code from condenser interface PCB by placing rotary dials to position 1 / 1 / 1 for diagnosis.
H16 01	TK1 oil sensor does not detect temperature change while compressor 1 operates. Detected at outdoor. Likely cause oil line (TK1) sensor condition / location, outdoor PCB fault sensor value 20°C=63k ohms
H16 02	TK2 oil sensor does not detect temperature change while compressor 2 operates. Detected at outdoor. Likely cause oil line (TK2) sensor condition / location, outdoor PCB fault sensor value 20°C=63k ohms
H16 03	TK3 oil sensor does not detect temperature change while compressor 3 operates. Detected at outdoor. Likely cause oil line (TK3) sensor condition / location, outdoor PCB fault sensor value 20°C=63kΩ
H16 04	TK4 oil sensor does not detect temperature change while compressors operate. Detected at outdoor. Likely cause oil line (TK4) sensor condition / location, outdoor PCB fault sensor value 20°C=63kΩ
H16 05	TK5 oil sensor does not detect temperature change while compressors operate. Detected at outdoor. Likely cause oil line (TK5) sensor condition / location, outdoor PCB fault sensor value 20°C=63kΩ
H25	Compressor discharge temperature does not increase while compressor 3 operates. Detected at outdoor. Likely cause compressor discharge sensor (Td3) condition / location, outdoor PCB fault sensor value 20°C=63k ohms
L03	Two or more lead units within group of indoor units. Detected indoors. Likely cause incorrect addressing, alteration in grouped set-up / wiring, requires re-addressing
L04	Duplicated outdoor line address. Detected at outdoor. Likely cause failure to correctly set line address before auto addressing
L05	Duplicated priority indoor unit, displayed on priority indoor unit. Detected indoors. Likely cause two units configured as priority units, correct configuration within engineer's menu 04
L06	Duplicated priority indoor unit, displayed on other than priority indoor unit. Detected indoors. Likely cause two units configured as priority units, correct configuration within engineering menu code 04
L07	Indoor unit group address incorrectly set. Detected indoors. Likely cause alteration of indoor group set-up, re-address required
L08	Indoor group / addresses unset. Detected at outdoor. Likely cause automatic addressing in-completed
L09	Indoor PCB capacity unset. Detected indoors. Likely cause failure to follow instruction accompanying new PCB
L10	Outdoor PCB capacity unset. Detected at outdoor. Likely cause failure to follow instructions accompanying new PCB
L17	Inconsistency of outdoor unit models. Detected at outdoor. Likely cause incorrect selection on outdoor model references
L18	Flow Selector unit error. Detected indoors. Likely cause indoor unit unable to heat on demand. Check power & communication to F/S Box from local indoor unit. Incorrectly configured indoor group sharing F/S box
L20	Duplicated central controller address. Detected indoors. Likely cause incorrectly set network address. Engineering code 03
L28	Quantity of outdoor units to high. Detected at outdoor. Likely cause to many outdoor units modularised together
L29	IPDU /PCB communication error. Detected at outdoor. Likely cause Split equipment=faulty or overheating inverter PCB. VRF equipment=loss in communication between condenser PCB's. Retrieve fault sub-code from condenser interface PCB by placing rotary dials to position 1 / 1 / 1 for diagnosis. Search fault code (without spaces) for diagnosis e.g. L2901

Code	Fault Description
L29 01	Compressor 1 IPDU board communication error. Detected at outdoor. Likely cause check communication cable linking all PCB's, replace Compressor 1 IPDU board
L29 02	Compressor 2 IPDU board communication error. Detected at outdoor. Likely cause check communication cable linking all PCB's, replace Compressor 2 IPDU board
L29 03	Compressor 1 & 2 IPDU board communication error. Detected at outdoor. Likely cause check communication cable linking all PCB's, replace Compressor 1 & 2 IPDU board
L29 04	Communication failure between PCB within condenser. Detected at outdoor. Fault Code is outdoor model series specific e.g. MMY-MAP###1HT8-E, MMY-AP###2HT8-E or MMY-MAP###4HT8-E therefore example fault code for L2904 will be (MMY-MAP0801HT8-E (series 1), MMY-MAP0802HT8-E (series 2), MMY-MAP0804HT8-E (series 4) search L29041, L29042 or L29044
L29 04 1	Fan IPDU board communication error. Detected at outdoor. Likely cause check communication cable linking all PCB's, replace fan IPDU board
L29 04 2	Fan IPDU board communication error. Detected at outdoor. Likely cause check communication cable linking all PCB's, replace fan IPDU board
L29 04 4	Compressor 3 IPDU board communication error. Detected at outdoor. Likely cause check communication cable linking all PCB's, replace Compressor 3 IPDU board
L29 05	Communication failure between PCB within condenser. Detected at outdoor. Fault Code is outdoor model series specific e.g. MMY-MAP###1HT8-E, MMY-AP###2HT8-E or MMY-MAP###4HT8-E therefore example fault code for L2905 will be (MMY-MAP0801HT8-E (series 1), MMY-MAP0802HT8-E (series 2), MMY-MAP0804HT8-E (series 4) search L29051, L29052 or L29054
L29 05 1	Compressor 1 IPDU & fan IPDU board communication error. Detected at outdoor. Likely cause check communication cable linking all PCB's, replace Compressor 1 IPDU & fan IPDU board
L29 05 2	Compressor 1 IPDU & fan IPDU board communication error. Detected at outdoor. Likely cause check communication cable linking all PCB's, replace Compressor 1 IPDU & fan IPDU board
L29 05 4	Compressor 1 & 3 IPDU board communication error. Detected at outdoor. Likely cause check communication cable linking all PCB's, replace Compressor 1 & 3 IPDU board
L29 06	Communication failure between PCB within condenser. Detected at outdoor. Fault Code is outdoor model series specific e.g. MMY-MAP###1HT8-E, MMY-AP###2HT8-E or MMY-MAP###4HT8-E therefore example fault code for L2906 will be (MMY-MAP0801HT8-E (series 1), MMY-MAP0802HT8-E (series 2), MMY-MAP0804HT8-E (series 4) search L29061, L29062 or L29064
L29 06 1	Compressor 2 IPDU & fan IPDU board communication error. Detected at outdoor. Likely cause check communication cable linking all PCB's, replace Compressor 2 IPDU & fan IPDU board
L29 06 2	Compressor 2 IPDU & fan IPDU board communication error. Detected at outdoor. Likely cause check communication cable linking all PCB's, replace Compressor 2 IPDU & fan IPDU board
L29 06 4	Compressor 2 & 3 IPDU board communication error. Detected at outdoor. Likely cause check communication cable linking all PCB's, replace Compressor 2 & 3 IPDU board
L29 07	Communication failure between PCB within condenser. Detected at outdoor. Fault Code is outdoor model series specific e.g. MMY-MAP###1HT8-E, MMY-AP###2HT8-E or MMY-MAP###4HT8-E therefore example fault code for L2907 will be (MMY-MAP0801HT8-E (series 1), MMY-MAP0802HT8-E (series 2), MMY-MAP0804HT8-E (series 4) search L29071, L29072 or L29074 for diagnosis
L29 07 1	Communication error between PCB within condenser. Detected at outdoor. Likely cause check communication cable linking all PCB's, phase missing on power supply, replace interface PCB

Code	Fault Description
L29 07 2	Communication error between PCB within condenser. Detected at outdoor. Likely cause check communication cable linking all PCB's, phase missing on power supply, replace interface PCB
L29 07 4	Compressor 1, 2 & 3 IPDU board communication error. Detected at outdoor. Likely cause check communication cable linking all PCB's, replace Compressor 1, 2 & 3 IPDU board
L29 08	Fan IPDU board communication error. Detected at outdoor. Likely cause check communication cable linking all PCB's, replace fan IPDU board
L29 09	Compressor 1 IPDU & fan IPDU board communication error. Detected at outdoor. Likely cause check communication cable linking all PCB's, replace Compressor 1 IPDU & fan IPDU board
L29 0A	Compressor 2 IPDU & fan IPDU board communication error. Detected at outdoor. Likely cause check communication cable linking all PCB's, replace Compressor 2 IPDU & fan IPDU board
L29 0B	Compressor 1 & 2 IPDU board & fan IPDU board communication error. Detected at outdoor. Likely cause check communication cable linking all PCB's, replace Compressor 1 & 2 IPDU PCB & fan IPDU board
L29 0C	Compressor 3 IPDU board & fan IPDU board communication error. Detected at outdoor. Likely cause check communication cable linking all PCB's, replace Compressor 3 IPDU board & fan IPDU board
L29 0d	Compressor 1 & 3 IPDU board & fan IPDU board communication error. Detected at outdoor. Likely cause check communication cable linking all PCB's, replace Compressor 1 & 3 IPDU board & fan IPDU board
L29 0E	Compressor 2 & 3 IPDU board & fan IPDU board communication error. Detected at outdoor. Likely cause check communication cable linking all PCB's, replace Compressor 2 & 3 IPDU PCB & fan IPDU board
L29 0F	Communication error between PCB within condenser. Detected at outdoor. Likely cause check communication cable linking all PCB's, phase missing on power supply, replace interface PCB
L30	Auxiliary interlock in indoor unit. Detected indoors. Likely cause external interlock in CN80 socket on indoor unit
P01	Indoor fan motor error. Detected indoors. Likely cause indoor fan motor or wiring to motor
P03	High compressor discharge temperature. Detected at outdoor. by TD1 @ 115°C. Likely cause low refrigerant, poor refrigerant flow and airflows & TD1 sensor condition sensor value 20°C=63k ohms
P04	High pressure switch activation. Detected at outdoor. Likely cause poor airflows over indoor / out dependant on operation, restriction in refrigerant flow, non-condensable mixed with refrigerant. Fault sub code required to determine which H.P Switch activated 01=compressor 1 02=compressor 2 03=compressor 3. Retrieve fault sub-code from condenser interface PCB by placing rotary dials to position 1 / 1 / 1 for diagnosis.
P04 01	Compressor 1 high pressure switch activation. Detected at outdoor. Likely cause poor airflows over indoor / out dependant on operation, restriction in refrigerant flow, non-condensable mixed with refrigerant
P04 02	Compressor 2 high pressure switch activation. Detected at outdoor. Likely cause poor airflows over indoor / out dependant on operation, restriction in refrigerant flow, non-condensable mixed with refrigerant
P04 03	Compressor 3 high pressure switch activation. Detected at outdoor. Likely cause poor airflows over indoor / out dependant on operation, restriction in refrigerant flow, non-condensable mixed with refrigerant
P05	Phase-missing detection / phase order error, compressor inverter High Voltage. Retrieve fault sub-code from condenser interface PCB by placing rotary dials to position 1 / 1 / 1 for diagnosis. Search fault code (without spaces) for diagnosis e.g. P0501
P05 00	Phase-order incorrect or phase missing. Detected at outdoor. Likely cause issue with power supply to condenser, or phase order wrong, swap L2 & L3

Code	Fault Description
P05 01	Phase-missing detection (series 1 & 2) or High D.C. inverter voltage (series 4). Detected at outdoor. Fault Code is outdoor model series specific e.g. MMY-MAP###1HT8-E, MMY-AP###2HT8-E or MMY-MAP###4HT8-E therefore example fault code for P0501 will be (MMY-MAP0801HT8-E (series 1), MMY-MAP0802HT8-E (series 2), MMY-MAP0804HT8-E (series 4) search P05011, P05012 or P05014
P05 01 1	Phase-missing detection. Detected at outdoor. Likely cause error on power supply to condenser
P05 01 2	Phase-missing detection. Detected at outdoor. Likely cause error on power supply to condenser
P05 01 4	High D.C. inverter voltage. Detected at outdoor. Likely cause compressor 1 IPDU board overheat or failure
P05 02	Phase-order incorrect (series 1 & 2) or High D.C. inverter voltage (series 4). Detected at outdoor. Fault Code is outdoor model series specific e.g. MMY-MAP###1HT8-E, MMY-AP###2HT8-E or MMY-MAP###4HT8-E therefore example fault code for P0502 will be (MMY-MAP0801HT8-E (series 1), MMY-MAP0802HT8-E (series 2), MMY-MAP0804HT8-E (series 4) search P05011, P05012 or P05014
P05 02 1	Phase-order incorrect. Detected at outdoor. Likely cause issue with power supply to condenser, swap L2 & L3 to correct
P05 02 2	Phase-order incorrect. Detected at outdoor. Likely cause issue with power supply to condenser, swap L2 & L3 to correct
P05 02 4	High D.C. inverter voltage. Detected at outdoor. Likely cause compressor 2 IPDU board overheat or failure
P05 03	High D.C. inverter voltage. Detected at outdoor. Likely cause compressor 3 IPDU board overheat or failure
P07	Overheating compressor IPDU / inverter board. Detected at outdoor. Likely cause poorly secured inverter PCB to heat-sink, faulty IPDU. Fault sub code required to determine which IPDU overheated 01=IPDU1 02=IPDU2 03=IPDU3. Retrieve fault sub-code from condenser interface PCB by placing rotary dials to position 1 / 1 / 1 for diagnosis.
P07 01	Overheating compressor 1 IPDU / inverter board. Detected at outdoor. Likely cause poorly secured inverter PCB to heat-sink, faulty IPDU board 1
P07 02	Overheating compressor 2 IPDU / inverter board. Detected at outdoor. Likely cause poorly secured inverter PCB to heat-sink, faulty IPDU board 2
P07 03	Overheating compressor 3 IPDU / inverter board. Detected at outdoor. Likely cause poorly secured inverter PCB to heat-sink, faulty IPDU board 3
P10	Indoor float switch open circuit as result of high condensation levels within drip tray, detected indoors. Likely cause faulty float switch, faulty lift pump, debris blocking drain
P12	Indoor fan motor trouble. Detected indoors. Likely cause fan motor locked, incorrectly configured PCB, indoor PCB fault
P13	Outdoor liquid back detection in condenser while in OFF cycle. Detected at outdoor. Likely cause increase in pressure within dormant condenser, possible PMV valves passing
P15	High compressor suction or discharge temperature. Detected at outdoor. Likely cause sensor condition (TS1 or TD1, 2 or 3), interface PCB fault, loss of refrigerant TS1 sensor value 20°C=12.5k ohms TD1,2 & 3 sensor value 20°C=63k ohms. Retrieve fault sub-code from condenser interface PCB by placing rotary dials to position 1 / 1 / 1 for diagnosis.
P15 01	High compressor suction temperature. Detected at outdoor. Likely cause suction sensor condition (TS1), interface PCB fault, loss of refrigerant sensor value 20°C=12.5k ohms
P15 02	High compressor discharge temperature. Detected at outdoor. Likely cause discharge sensor condition (TD1, TD2 or TD3), interface PCB fault, loss of refrigerant sensor value 20°C=63k ohms
P17	High compressor discharge temperature. Detected at outdoor. by TD2 @ 115°C. Likely cause low refrigerant, poor refrigerant flow and airflows & TD2 sensor condition sensor value 20°C=63k ohms
P18	High compressor discharge temperature. Detected at outdoor. by TD3 @ 115°C. Likely cause low refrigerant, poor refrigerant flow and airflows & TD3 sensor condition sensor value 20°C=63k ohms
P19	Incorrect temperature / pressure reading at condenser. Detected at outdoor. Likely cause check characteristics of pressure transducers (PS & Pd) and temperature sensors (TS1, TE1 & TL), interface PCB fault sensor value 20°C=12.5k ohms

Code	Fault Description
P20	High pressure protection detected by discharge pressure transducer reading @ 36bar. Detected at outdoor. Likely cause characteristics of discharge pressure transducer (Pd), interface PCB, poor airflows across condensers
P22	Outdoor fan motor error. Detected at outdoor. Likely cause Split equipment, locked / faulty fan motor, faulty PCB VRF Equipment. Retrieve fault sub-code from condenser interface PCB by placing rotary dials to position 1 / 1 / 1 for diagnosis. Search fault code (without spaces) for diagnosis. e.g. P2203
P22 03	Outdoor fan motor error. Detected at outdoor. Likely cause locked / faulty fan motor, faulty fan IPDU PCB. Fan motor has 3 ohms resistance on any 2 wires
P22 34	Outdoor fan motor error. Detected at outdoor. Likely cause locked / faulty fan motor, faulty fan IPDU PCB. Fan motor has 3 ohms resistance on any 2 wires
P22 37	Outdoor fan motor error. Detected at outdoor. Likely cause locked / faulty fan motor, faulty fan IPDU PCB. Fan motor has 3 ohms resistance on any 2 wires
P22 E1	Fan IPDU board error. Detected at outdoor. Likely cause error on DC supply voltage to fan IPDU PCB or problem with mains voltage onto condenser
P22 E2	Fan IPDU board error. Detected at outdoor. Likely cause error on DC supply voltage to fan IPDU PCB or problem with mains voltage onto condenser
P22 E3	Fan IPDU board error. Detected at outdoor. Likely cause error on DC supply voltage to fan IPDU PCB or problem with mains voltage onto condenser
P26	Compressor IPDU PCB Short circuit. Detected at outdoor. Likely cause electrical fault on compressor, faulty compressor inverter board. Before replacing PCB prove compressor is good. Retrieve fault sub-code from condenser interface PCB by placing rotary dials to position 1 / 1 / 1 for diagnosis.
P26 01	Compressor 1 IPDU PCB Short circuit. Detected at outdoor. Likely cause electrical fault on compressor 1, faulty compressor 1 inverter board. Before replacing PCB prove compressor is good
P26 02	Compressor 2 IPDU PCB Short circuit. Detected at outdoor. Likely cause electrical fault on compressor 2, faulty compressor 2 inverter board. Before replacing PCB prove compressor is good
P26 03	Compressor 3 IPDU PCB Short circuit. Detected at outdoor. Likely cause electrical fault on compressor 3, faulty compressor 3 inverter board. Before replacing PCB prove compressor is good
P29	Compressor position detection error. Detected at outdoor. Likely cause fault on compressor, faulty compressor inverter board. Before replacing inverter, PCB prove compressor is good. Retrieve fault sub-code from condenser interface PCB by placing rotary dials to position 1 / 1 / 1 for diagnosis.
P29 01	Compressor 1 position detection error. Detected at outdoor. Likely cause fault on compressor 1, faulty compressor 1 inverter board. Before replacing inverter, PCB prove compressor is good
P29 02	Compressor 2 position detection error. Detected at outdoor. Likely cause fault on compressor 2, faulty compressor 2 inverter board. Before replacing inverter, PCB prove compressor is good
P29 03	Compressor 3 position detection error. Detected at outdoor. Likely cause fault on compressor 3, faulty compressor 3 inverter board. Before replacing inverter, PCB prove compressor is good
P30	Indoor unit other than lead indoor suffering fault. Detected on central controller. Likely cause to diagnose retrieve fault code from local remote controller to indoor group
P31	Indoor unit other than lead indoor suffering fault. Detected indoors. Likely cause to diagnose retrieve fault code from local remote controller to indoor group

Error Detected by - TCC-Link Central Controller

Check Code				Wireless Remote				Check Code Name	Judging Device
Central Control Device	Outdoor 7 Segment Display		AI Central Controller	Sensor Block Display					
		Auxiliary Code		O	T	R	F		
C05	---	---	---	---				Sending error in TCC-Link central control device	TCC-LINK
C06	---	---	---	---				Receiving error in TCC-Link central control device	TCC-LINK
C12	---	---	---	---				Batch alarm of general-purpose equipment control interface	HA control interface I/F
P30	---	Differs according to error contents of unit with occurrence of alarm						Group control follower unit error	TCC-LINK
		---	(L20 is displayed)			Duplicated central control addresses			

Black Pear Error Code Cross Reference.					
Black Pear Error Code	Toshiba Error Code	Description	Black Pear Error Code	Toshiba Error Code	Description
1005	C05	Sending error in TCC-Link central control device	3001	F01	Indoor TCCJ sensor error
1006	C06	Receiving error in TCC-Link central control device	3002	F02	Indoor TC2 sensor error
1012	C12	Batch alarm of general-purpose equipment control interface	3003	F03	Indoor TC1 sensor error
2001	E01	Communication error between indoor and remote controller (Detected at remote controller side)	3004	F04	TD1 sensor error
2003	E03	Communication error between indoor and remote controller (Detected at indoor side)	3005	F05	TD2 sensor error
			3006	F06	TE1 sensor error
2004	E04	Communication circuit error between indoor / outdoor (Detected at indoor side)	3007	F07	TL sensor error
2006	E06	Decrease of number of indoor units.	3008	F08	TO sensor error
2007	E07	Communication circuit error between indoor / outdoor (Detected at outdoor side)	3010	F10	TA sensor error
2008	E08	Duplicated indoor addresses	3012	F12	TS1 sensor error
2009	E09	Duplicated master remote controllers	3013	F13	TH sensor error
2010	E10	Communication error between indoor Boards	3015	F15	Outdoor temperature sensor misconnection (TE1-TL)
2012	E12	Automatic address start error	3016	F16	Outdoor pressure sensor misconnection (Pd – Ps)
2015	E15	No indoor automatic address	3023	F23	Ps sensor error
2016	E16	Over capacity / Number of connected indoor units	3024	F24	Pd sensor error
2018	E18	Communication error between indoor header and follower units.	3029	F29	Indoor other error
2019	E19	Outdoor header unit's quantity error	3031	F31	Outdoor EEPROM error
2020	E20	Other line connected during automatic address	4001	H01	Compressor break down
2023	E23	Sending error in communication between outdoor units	4002	H02	Magnetic switch error / Overcurrent relay operation / Compressor error (lock)
2025	E25	Duplicated follower outdoor address	4003	H03	Current detection circuit error
2026	E26	Decrease of number of connected outdoor units	4004	H04	Compressor 1 case thermal operation
2028	E28	Follower outdoor unit error	4006	H06	Low pressure protection operation
2031	E31	IPDU Communication error	4007	H07	Low oil level protection
			4008	H08	Oil level temperature sensor error
			4014	H14	Compressor 2 case thermal operation
			4016	H16	Oil level detection circuit error / Magnetic switch error / Overcurrent relay error

Black Pear Error Code Cross Reference.					
Black Pear Error Code	Toshiba Error Code	Description	Black Pear Error Code	Toshiba Error Code	Description
6003	L03	Duplicated indoor header units	7001	P01	Indoor fan motor error
6004	L04	Duplicated outdoor line address	7003	P03	Discharge temperature TD1 error
6005	L05	Duplicated indoor units with priority (Displayed in indoor unit with priority)	7004	P04	High-pressure switch detection error
			7005	P05	Phase-missing detection / Phase order error
6006	L06	Duplicated indoor units with priority (Displayed in unit other than indoor unity with priority)	7007	P07	Heat sink overheat error
			7010	P10	Indoor overflow error
6007	L07	Group line in individual indoor unit	7012	P12	Indoor fan motor error
6008	L08	Indoor group/Address unset	7013	P13	Outdoor liquid back detection error
6009	L09	Indoor capacity unset	7015	P15	Gas leak detection
6010	L10	Outdoor capacity unset	7017	P17	Discharge temperature TD2 error
6020	L20	Duplicated central control addresses	7019	P19	4-way valve inverse error
6028	L28	Maximum number of outdoor units exceeded	7020	P20	High pressure inverse error
6029	L29	Number of IPDU's error	7022	P22	Outdoor fan IPDU error
6030	L30	Auxiliary interlock in indoor unit	7026	P26	Giant Transistor short circuit protection error
6031	L31	IC error	7029	P29	Compressor position detection circuit error
			7030	P30	Follower indoor unit error (Group error)
Special Black Pear Error Codes			7031	P31	Follower indoor unit error (Group error)
6999	Unit does not exist on the system				
8000	No error detected				
255	No error detected.				

Notes

TCC-net Local Hard Wired Controller Guidelines

RAV & VRF



RBC-AS41E



RBC-ASC11E



RBC-MTSC1

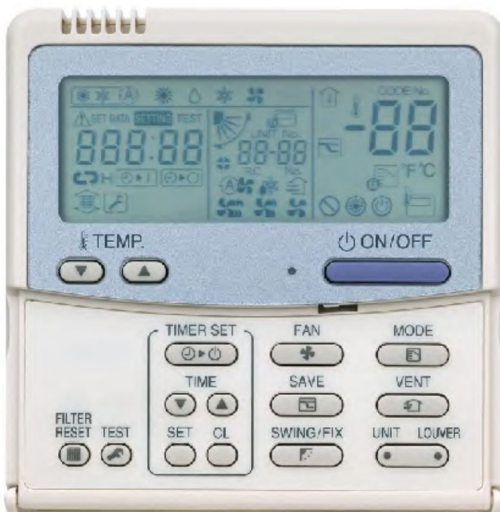

RBC-AMT32-E



RBC-AMS41-E



RBC-AMS51E



RBC-AMS54/55E-ES

System Configuration Menu

Hard wired remote controllers which allow access to the configuration menu are:
RBC-ASC11-E, RBC-AMT32-E, RBC-AMS41-E, RBC-AMS51E, RBC-AMS54/55E-ES.

RBC-AS41E, Infra-Red Remotes and Central Controllers **Cannot** be utilised for setting configuration items.

A number of items are configurable by a wired controller – if an indoor unit without a wired controller requires configuration, a wired remote can be temporarily connected for the procedure to be undertaken. In order to access the menu.

Press  + SET + CL for 4 seconds (RBC-AMT32/AMS41)

- The indoor units to be configured will be chosen by pressing the UNIT button.
- The indoor unit being configured runs its fan and swings its louvers (if possible).
- Use SET TEMPERATURE up/down buttons to scroll through the configurable items Use TIMER up/down buttons to choose the configuration value for Use
- SET to confirm configuration value Use CL to undo an incorrect setting provided that configurable item has not been changed)
- Use CHECK to return to normal operation.

EXAMPLES of COMMON CONFIGURABLE OPTIONS

ITEM	DESCRIPTION	VALUE	DEFAULT																																																							
01	Filter alarm time	Filter sign displayed after selected time has elapsed – or by external pressure switch (CN70)	0000: Inactive 0002: 250 H 0004: 1000 H 0001: 150 H 0003: 500 H 0005: External switch	0002																																																						
02	Dirty environment	Allows filter alarm time to be halved if used in a dirty environment	0000: Standard 0001: Dirty	0000																																																						
03	Network address	When under network control.	0099: Unset 0001 to 0064 available	0099																																																						
04	Priority Setting for Remote Controller	0 = Normal 1= Priority (This remote has priority of mode setting)	0000 = Standard 0001 = Priority	0000																																																						
06	Stratification control	Increases effective return air temperature setting in heating mode (0 to 10K)	0000 to 0010	0002; +2°C Floor type 0000; 0°C																																																						
0C	Preheat	Preheat indication on display	0000 = available 0001 = unavailable	0000																																																						
0d	Auto mode	Enable or disable Auto mode	0000 = available 0001 = unavailable	0000 except SMMSse																																																						
0E	SHRMI only	Used when multiple indoor units are served via a single FS box	0000 = normal 0001 = multiple units	0000																																																						
0F	Heat Mode	Enable or disable Heat Mode	0000 = available 0001 = unavailable	0000																																																						
10	Indoor unit model	Must be set when replacing indoor printed circuit board	0000: 1-way cassette (s models) 0001: 4-way cassette 0002: 2-way cassette 0003: 1-way cassette (y models) 0004: duct (standard) 0005: slim duct 0006: duct (high static) 0007: ceiling 0008: hi wall 0010: console 0011: concealed floor 0014: 4-way compact cassette (600 x 600) 0013: tall cabinet 0016: fresh air intake 0050: air to air heat exchanger																																																							
11	Indoor unit capacity	0000 will generate a (L09) fault	<table border="1" style="width: 100%; border-collapse: collapse; font-size: small;"> <thead> <tr> <th></th> <th>MM</th> <th>RAV</th> <th></th> <th>MM</th> <th>RAV</th> </tr> </thead> <tbody> <tr><td>0004</td><td>=005*</td><td>-</td><td>0012</td><td>=027*</td><td>80*</td></tr> <tr><td>0001</td><td>=007*</td><td>-</td><td>0013</td><td>=030*</td><td>90*</td></tr> <tr><td>0003</td><td>=009*</td><td>30*</td><td>0015</td><td>=036*</td><td>110*</td></tr> <tr><td>0005</td><td>=012*</td><td>-</td><td>0017</td><td>=048*</td><td>140*</td></tr> <tr><td>0006</td><td>-</td><td>40*</td><td>0018</td><td>=056*</td><td>160*</td></tr> <tr><td>0007</td><td>=015*</td><td>-</td><td>0021</td><td>=072*</td><td>224*</td></tr> <tr><td>0009</td><td>=018*</td><td>56*</td><td>0023</td><td>=096*</td><td>280*</td></tr> <tr><td>0011</td><td>=024*</td><td>-</td><td>-</td><td>-</td><td>-</td></tr> </tbody> </table> Air to air heat exchanger Type 0 0 0 1 = 150m ³ /h 0 0 0 6 = 800m ³ /h 0 0 0 2 = 250m ³ /h 0 0 0 7 = 1000m ³ /h 0 0 0 3 = 350m ³ /h 0 0 0 8 = 1500m ³ /h 0 0 0 4 = 500m ³ /h 0 0 0 9 = 2000m ³ /h 0 0 0 5 = 650m ³ /h		MM	RAV		MM	RAV	0004	=005*	-	0012	=027*	80*	0001	=007*	-	0013	=030*	90*	0003	=009*	30*	0015	=036*	110*	0005	=012*	-	0017	=048*	140*	0006	-	40*	0018	=056*	160*	0007	=015*	-	0021	=072*	224*	0009	=018*	56*	0023	=096*	280*	0011	=024*	-	-	-	-	
	MM	RAV		MM	RAV																																																					
0004	=005*	-	0012	=027*	80*																																																					
0001	=007*	-	0013	=030*	90*																																																					
0003	=009*	30*	0015	=036*	110*																																																					
0005	=012*	-	0017	=048*	140*																																																					
0006	-	40*	0018	=056*	160*																																																					
0007	=015*	-	0021	=072*	224*																																																					
0009	=018*	56*	0023	=096*	280*																																																					
0011	=024*	-	-	-	-																																																					
12	System number	DI/SDI indoor and outdoor units are automatically addressed, this value may be set manually but it must be done via the wired controller – on an individual basis. Settings are 0001 to 0030	0001: outdoor unit 1 0002: outdoor unit 2	0099																																																						
13	Indoor unit number	Indoor units connected to a common outdoor unit (e.g. twinned indoor units) will have the same system number - settings are 0001 to 0064. Automatically allocated – but may be manually overridden.	0001: indoor unit 1 0002: indoor unit 2	0099																																																						
14	Group master/slave	Allows selection of master indoor unit within group. Automatically allocated but may be manually overridden.	0000: single indoor unit 0001: group master 0002: group slave	0099																																																						
15	Temperature Sensor	Compensation for missing temperature sensor (split systems ONLY) other settings produce F03 fault code	0022	0022																																																						
16	Indoor Fan	Indoor fan speed selection. Binary addition.	0015 = all speeds available 1 = auto; 2 = low; 4 = medium; 8 = high	0015 except high static 0008																																																						
17	Set point shift	Cooling temperature set point shift. (shifted by 1 to 10 k)	0000 = no shift, 0010 = 10 k shift 0001 = 1 k shift, -	0000																																																						
19	Louver functions	None, swing only, swing and auto (where applicable)	0000: disabled, 0004: all options 0001: swing only																																																							
1b	Compressor on time	Compressor minimum on time (0 = 5 minutes 1 = 4 minutes)	0000: 0 – 5 min 0001: 1 - 4 min.	0000																																																						
1E	Dead band - auto	Changeover sensitivity in automatic mode. (1 to 10 k adjustable)	0000: 0 K, 0010: 10 K	0003																																																						

ITEM	DESCRIPTIPON	VALUE	DEFAULT												
1F	Max. Setting	Cooling mode maximum temperature setting (18 – 29°C)	0018 = 18°C, 0020 = 20°C 0029 = 29°C 29 ° C												
20	Min. Setting	Cooling mode minimum temperature setting (18 – 29°C)	0018 = 18°C, 0020 = 20°C 0029 = 29°C 18 ° C												
21	Max. Setting	Heating mode maximum temperature setting (18 – 29°C)	0018 = 18°C, 0020 = 20°C 0029 = 29°C 29 ° C												
22	Min. Setting	Heating mode minimum temperature setting (18 – 29°C)	0018 = 18°C, 0020 = 20°C 0029 = 29°C 18 ° C												
23	Max. Setting	Dry mode maximum temperature setting (18 – 29°C)	0018 = 18°C, 0020 = 20°C 0029 = 29°C 29 ° C												
24	Min. Setting	Dry mode minimum temperature setting (18 – 29°C)	0018 = 18°C, 0020 = 20°C 0029 = 29°C 18 ° C												
25	Max. Setting	Auto mode maximum temperature setting (18 – 29°C)	0018 = 18°C, 0020 = 20°C 0029 = 29°C 29 ° C												
26	Min. Setting	Auto mode minimum temperature setting (18 – 29°C)	0018 = 18°C, 0020 = 20°C 0029 = 29°C 18 ° C												
28	Auto restart	Enable or disable	0000: disabled 0001: enabled 0000												
29	Humidifier condition	Operating condition of humidifier	0000: Usual 0001: Condition ignored 0000												
2A	CN70	Selection of optional error input (CN70)	0000: Filter input 0001: Alarm input, 0002: None 0002												
2d	Modes available	Binary addition of modes available.	0015= all modes 1 = fan; 2 = cool; 4 = dry 8 = heat 0015												
2E	External On / Off control	Making or breaking terminals 1 and 2 of CN61 (indoor PCB) External switching option, remove jumper 01 master indoor PCB allows continuous contact switch- link 01 in place; pulse switch required	0000 = group starts when made stops when open 0001 = enable when made, disable when open 0000												
31	External fan control	Through remote controller and CN32 indoor PCB Used for setting ON/OFF control for VN-M units when paired with A/C systems	0000 = disable, 0001 = enabled 0000												
32	Sensor location	Return air/room sensor OR in local controller	0000: return air sensor 0001: remote sensor 0000												
33	Unit of temperature	Celsius or Fahrenheit	000 = Celsius, 0001 = Fahrenheit 0000												
36	Remote controller	Temperature display	0000: temperature setting 0001: temperature room sensing 0000												
40	Drain pump	Drain pump control	0000: None 0001: Pump ON 0002: None 0003: Pump OFF 0003												
45	Anti-smudge	4-way cassette anti smudge effect via louver position	0000 = enabled, 0001 = disabled 0000												
5d	1-Way Cassette Airflow Correction Ceiling height (m)	AP015, 018	AP024	0000	0000										
		3.5	3.8	0001											
		4.0	4.0	0003											
	2-Way Cassette Airflow correction Ceiling height (m)	AP007 to AP030	AP36 to AP056	0000	0000										
		2.7	2.7	0001											
		3.2	3.0	0003											
	4-Way Cassette Airflow correction Ceiling height (m)	-	RAV56*	RAV80*	RAV90*,110*,160*	0000									
		AP005 to AP012	AP015 to AP018	AP024 to AP030	AP036 to AP056										
		4-way	3-way	2-way	4-way		3-way	2-way	4-way	3-way	2-way	0000			
		2.7	2.8	3.0	2.8		3.2	3.5	3.0	3.3	3.6	3.9	4.2	4.5	0001
		-	-	-	3.2		3.5	3.8	3.3	3.5	3.8	4.2	4.4	4.6	0003
		-	-	-	3.5		3.8	-	3.6	3.8	-	4.5	4.6	-	0006
		4-Way Compact Cassette Airflow correction Ceiling height (m)	-	RAV40*	RAV56*		0000								
			AP007 to AP012	AP015	AP018										
			2.7	2.9	3.2										
		Slim Ducted Airflow correction External static pressure	-	RAV40*-56*	-		0000								
			AP0054	AP0074 to AP0184	AP0244 to AP0274										
			10 Pa	10 Pa	10 Pa										
	20 Pa		20 Pa	20 Pa											
	35 Pa		35 Pa	35 Pa											
Standard Ducted Airflow correction External static pressure	50 Pa	50 Pa	50 Pa	0006											
	RAV40*-56*	RAV80*	RAV110*-160*	0001											
	AP007 to AP018	AP024 to AP030	AP036 to AP058												
	30 Pa	30 Pa	30 Pa												
	40 Pa	40 Pa	40 Pa												
	50 Pa	50 Pa	50 Pa												
	65 Pa	65 Pa	65 Pa												
	80 Pa	80 Pa	80 Pa												
	100 Pa	100 Pa	100 Pa												
	120 Pa	120 Pa	120 Pa												
0006															
VN-M (HE1)	Maximum Fan Speed Selection	0000: High 0001: Extra High 0000													
60	Timer lock	Locks timer in wired local controller – maintaining last setting	0000: unlocked, 0001: locked 0000												
62	Anti-smudge	4-way cassette – ant smudge via fan speed (Coanda effect)	0000 0001												
69	Louver	Louver restriction when cooling	0000 = restricted to horizontal positions 0001 = full range of movement 0000												
6E	Setting for air direction kit (1)	Smart Cassette ONLY.	GM56	GM80	GM110	GM140	0000								
			Standard	0000	0000	0000		0000							
			3-way air flow	0000	0000	0080		0075							
			2-way air flow	0090	0090	0080		0070							
77	Dual set point	RBC-AMS54/55E-ES ONLY	0000 = Available 0001 = Unavailable 0000												
88	Setting for air direction kit (2)	Smart Cassette ONLY.	GM56	GM80	GM110	GM140	According to capacity type.								
			Standard	0000	0072	0075		0070							
			3-way air flow	0060	0060	0050		0048							
			2-way air flow	0050	0050	0040		0038							
8b	Heating Correction	Heating output reduction split systems only	0000: None, 0001: Correction 0000												
8c	Forced Defrost	Run group in HEAT mode after setting defrost is conducted automatically. Value is reset automatically back to 0000	0000 = disabled 0001 = enabled 0000												
A0	Fan & Pump	Fan and pump operation during oil retrieval mode (VRF cassettes ONLY)	0000 = fan off, pump on 0003 = fan on, pump on 0003												
b3	Soft Cooling	RBC-AMS54/55E-ES	0000 = Unavailable 0001 – Available 0001												
b5	Occupancy Sensor	Where applicable	0000 = None 0001 = Occupancy sensor provided 0000												
b6	Occupancy sensor	Enable / Invalid. Absence time judgement time.	0000 = Invalid, 0001 = 30min. 0002 = 60min. 0004 = 120min. 0005 = 150min. 0002												
b7	Occupancy sensor	Operation at absent time.	0000 = Standby 0001 = Operation stop 0000												
C2	Energy save	Outdoor unit energy demand 1% increments 50 to 100%	0050 ~ 0100 0000 = disable 0006 = RAV40* 0009 = RAV56* 0012 = RAV80* 0015 = RAV110* 0017 = RAV140* 0018 = RAV160* 0000												
CE	Replace indoor PCB	4-Way cassette unit capacity code	0000												
d0	Power Saving Mode	Whether the power saving mode can be set by the remote controller	0000 = Invalid 0001 = Valid 0001												

ITEM	DESCRIPTION		VALUE	DEFAULT
d3	Self-clean operation	Self-clean dry operation	0000 = disable 0001 = enable	0001
E6	Wireless Channel	Compact Cassette. Channel selection	0000 = A channel, 0001 = B channel	0000
F0	Swing mode	Compact Cassette. Louver swing options	0001 = Standard, 0002 = Dual swing 0003 = Cycle swing	0001
F1	Louvre lock Flap 1	4-Way cassette 5 fixed positions	0000 Full swing	0000
F2	Louvre lock Flap 2		0001 Fixed position 1 (Horizontal Discharge)	
F3	Louvre lock Flap 3		0002 Fixed position 2	
F4	Louvre lock Flap 4		0003 Fixed position 3	
F4	Louvre lock Flap 4		0004 Fixed position 4	
F6	Application control kit	Presence of Application Control Kit (TCB-PCUC1/2E-1)	0000 = None, 0001 = Exist	0000

Note: Some options are model specific.

Notes

Optional Control Accessories								
	ITEM	RAV	VRF	VN	ESTIA	RAS	DESCRIPTION	DETAILS
Wired Controllers	RBC-AMT32E	✓	✓				Standard Remote Controller	Full Control Including Service Function
	RBC-AMS41E	✓	✓				Remote Controller Built-in Timer	Full Control Including Service Function and Programmable 24/7 Day Timer
	RBC-AMS51E-ES*	✓	✓				LITE-Vision Plus Remote Controller	Includes Timer and Backlight Display, Power Save Functions, Multilingual.
	RBC-AMS54*/55E-ES	✓	✓				Remote Controller Built-in Timer	Programmable Timer, Backlight, Multilingual, Dual Set Point, Soft Cooling & Return Back Functions.
	RBC-AMS41E2*	✓	✓				Simplified Controller	Ideal for Hotel and Base use Applications, (No Service Function Available)
	RBC-ASC11E	✓	✓				Compact Local Controller	Ideal for Hotel and Base use Applications, (Service Function Available)
	RBC-MTSC1	✓	✓				Colour Smart Touch Local Remote	Ideal for Hotel and Base use Applications, (No Service Function Available)
	NRC-01HE				✓		VN-M Remote Controller	Remote controller for Air to Air Heat Exchangers.
	RBC-RWS20E					✓	Remote Controller for RAS	Wired Remote Controller for RAS Ducted Units
	TCB-EX21TLE	✓	✓				Scheduled Timer	Use with Central Controllers, BMS-CM1280TLE, BMS-SM1280ETLE, TCB-CC163TLE2, RBC-AMT32E, NRC-01HE
	HWS-AMS54E				✓		Standard Air to Water Remote	Estia Air to water Remote Controller
TCB-TC41LE	✓	✓				Auto-configurable Remote Sensor	Automatic control of Room Temperature Sensing Comfort Condition of system.	
Wireless Controllers	RBC-AX32(W/WS-E)	✓	✓				4-Way Cassette Corner Receiver	Replacement Corner Pocket with Built-in Receiver and Remote Controller
	RBC-AX32UM(W)-E	✓	✓				7-Series Compact Cassette Corner Receiver	Replacement Corner Pocket with Built-in Receiver and Remote Controller
	RBC-AX32UW(W)-E		✓				2-Way Cassette Receiver	Replacement Receiver and Remote Controller
	RBC-AX33CE	✓	✓				Under Ceiling Receiver	Replacement Receiver and Remote Controller
	TCB-AX32E2	✓	✓				Independent External Receiver	Receiver and Remote Controller for all Models
Central Controllers	TCB-CC163TLE2*	✓	✓	✓			16 Zone On-Off Controller	Enables the Switching On and Off by Volt Free Contact
	BMS-CM1280TLE*	✓	✓	✓			Compliant Manager	Enables Full Control of up to 128 Indoor Units.
	TCB-SC643TLE	✓	✓	✓			64 Zone Central Remote	Enables Full Control of up to 64 Indoor Units.
	BMS-SM1280ETLE	✓	✓	✓			128 Zone, Smart Manager with Data Analyser	Smart Manager with Remote Access via Web Browser and Data Analysis Features.
	BMS-CT1280E	✓	✓	✓			128 Zone, Colour Touch Screen with Data Analyser	Full Control of up to 128 Indoor Units with Remote Access via Web Browser and Data Analysis Features.
	BMS-CT512E	✓	✓	✓			512 Zone, Colour Touch Screen with Data Analyser	Full Control of up to 512 Indoor Units with Remote Access via Web Browser and Data Analysis Features.
	RBC-TBPTS	✓	✓	✓			64 Zone, Colour Touch Screen Central	Colour Touch Screen Central Remote Controller to control up to 64 Indoor Units
Indoor Interfaces	TCB-SIR41UM-E	✓	✓				7-Series Compact Cassette Occupancy Sensor	Occupancy Sensor (PIR)
	TCB-PCNT30TLE2	✓					Network Adaptor U3/U4 TCCJ Link	Allows connection of RAV units to the TCCJ Link Network
	TCB-PCNT20E	✓					Network Adaptor XY AI Network	Connects a RAV unit to the old AI Network.
	TCB-PX30MUE	✓					Terminal Box	Enclosure when used with all RAV Cassette Units.
	RBC-SMF1	✓	✓				Fan Interface	Interface to provide an output to enable an external fan from the indoor unit.
	RBC-SMIM2	✓	✓				Indicator Module Mode	Interface to Indicate the Mode of Operation, Output for Cool, Heat and Fan Only.
	RBC-SMIM3	✓	✓				Indicator Module ON/OFF and Fault	Interface to indicate Unit Operation and Stopping Fault.
	RBC-SMIM4	✓	✓				Indicator Module ON/OFF, Stopping Fault and Unit Enable	Interface to Indicate Unit Operation and Stopping Fault, also has connections to Enable the Unit.
	RBC-FDP3-PE	✓	✓				BMS Interface	Interface to Connect to a 0 to 10v or Resistance Based BMS, also has Modbus Functionality.
	RBC-TS1	✓	✓				Monitoring and Control Interface	Interface to Connect to a 0 to 10v or Resistance Based BMS, also has Modbus Functionality.
	RBC-IT2-PE	✓					Timer Interface	Interface to Accept 230v Input from a Timer for R22/R407C Systems.
	RBC-IT3-PE					✓	Daiseikai / Avant Timer Interface	Connects to "HA" Socket on Indoor Unit.
	TCB-PCOS1E2	✓		✓ ¹			Application Control PCB	Compatible models, RAV-SM/SP/GP + VN-M (HE1)
	TCB-PCM03E				✓		External Input PCB	Interface to Provide External ON/OFF for Estia System
	TCB-PCIN3E				✓		Output PCB	Interface to Provide an Output for Estia Fault/Run.
	TCB-IFGSM1E	✓					GSM Control Interface	Connects to CN61 at indoor PCB on RAV allowing remote ON/OFF, Operation Status and Alarm Monitoring.
	TCB-KBCN600PE	✓	✓				Operation Status	Operation Status of Indoor Units via Indoor PCB "CN61" socket.
	RBC-VNL1			✓			Unit Interface Lead	Volt Free Interface for VN-M###HE1 units to Control ON/OFF, Fan Speed and Damper Position.
	RBC-CN61	✓	✓				On/Off Interface	Remotely Switches Unit ON/OFF, via NO VOLT interface, Connects to indoor PCB "CN61" Socket.
	CDL-BMS01	✓	✓				On/Off Interface with Operation and Fault	Connects to the "CN61" socket on Indoor PCB, allowing for remote VOLT FREE On/OFF, System Operation and System Fault via 12volt Interface

Notes: * No longer available, ¹ VN-M###HE1 only

Optional Control Accessories								
	ITEM	RAV	VRF	VN	ESTIA	RAS	DESCRIPTION	DETAILS
Outdoor Interfaces	TCB-PCDM4E		✓				Power Peak Control	Power Peak Cut Control
	TCB-PCIN4E		✓				Operation Output Display	Operation/Error Output Display, Compressor Operation Control.
	TCB-PCM04E		✓				Operation Control	Night Set Back Control, Snowfall Fan Control, External ON/OFF, Operation Mode Control.
	TCB-PC051E2*		✓				Outdoor Control	Peak Power Cut and Noise Reduction, Output for Compressor Operation. (*Not applicable to all units.)
Other Accessories	RBC-FSEX15		✓				3 Series Flow Selector Lead	15m Extension Lead Kit for 3 Series SHRMe/i/e Flow Selector Box.
	RBC-SMT1	✓ ²	✓ ²				Timer Interface Lead	Provides ON/OFF Control from Wired Remote or Central Remote Controllers. (*excludes RBC-AS41E2)
	RBC-CK1	✓					VRF to RAV Conversion Kit	Kit to Convert VRF Floor/Chassis units to Connect with RAV Outdoor Units (R410A ONLY).
	RBC-CK2	✓					VRF to RAV Conversion Kit	Kit to Convert VRF Tall Floor Units to Connect with RAV Outdoor Units (R410A ONLY).
	TCB-KB052E	✓					Optional Connection Interface	RAVSP804/1604 Peak-Cut Control, Night Operation, Compressor Status.
BMS Interfaces	CDL-BMS02	✓	✓				Modbus Interface	Modbus Interface for control of up to 64 indoor units
	CDL-BMS03	✓	✓				BACnet Interface	BACnet interface for control of up to 64 indoor units
	CDL-BMS04	✓	✓				Trend Interface	Trend interface for control of up to 64 indoor units, requires IQ3/IQ4
	OASIS-064EM1	✓	✓				Control Solution	Control panel for 64 indoor unit's c/w data logging, web server & optimisation
	OASIS-128EM1	✓	✓				Control Solution	Control panel for 128 indoor unit's c/w data logging, web server & optimisation
	TCB-IFMB641TLE	✓	✓				Modbus Interface	Connect the system to a Modbus Building Management System control up to 64 indoor units
WIFI Interfaces	RB-N103S-G					✓	WIFI Connection	Toshiba RAS WIFI interface, suitable for: Daiseikai-10,13,16, Shorai -18,22,24, Seiya- 24
	RB-N105S-G					✓	WIFI Connection	Toshiba RAS WIFI interface, suitable for: Shorai-10,13,17, Seiya-05.07,10,16,18, Console-10,13,18
	BMS-IWF0320E	✓	✓				WIFI Connection	Toshiba RAV-VRF WIFI interface, maximum quantity of indoor units 32, IOS or Android App.
	RBC-IS-IF-Wifi-1	✓	✓			✓	WIFI Connection	Intensishome WIFI Universal Interface Infrared Remote RAS/RAV/VRF
	RBC-TO-RC-Wifi-1	✓	✓				WIFI Connection	Intensishome WIFI Interface for Wired Remotes RAV/VRF.
Refrigerant Leak Detection	TCB-LDS1	✓	✓				White Ref. Leak Detector	Leak detection concentration sensor with White Faceplate and remote 12 V transformer
	TCB-LDS2	✓	✓				Stainless Steel Ref. Leak Detector	Leak detection sensor with Stainless Steel Faceplate and remote 12 V transformer
	RBC-RCS1	✓	✓				White Ref. Leak Detector	Leak detection concentration sensor with White Faceplate
	RBC-RCS2	✓	✓				Stainless Steel Ref. Leak Detector	Leak detection concentration sensor with Stainless Steel Faceplate
	TCB-LD12V	✓	✓				Remote Power Supply	Leak detection transformer 12 V and cable kit (use with TCB-LDS1/TCB-LDS2)
	TCB-LD1	✓	✓				External Leak Detection and Pump Back panel	Leak Detection Panel VRF SHRMe/SMMSe
	TCB-LD2	✓	✓				External Leak Detection and Pump Back Panel	Leak Detection Panel VRF SHRMe/SMMSe
	RBC-RP1	✓	✓				Refrigerant Leak Detection Repeater Panel	Repeater Panel
Auxiliary Options	TCB-GFC1603UE	✓					Fresh air filter chamber	4- Smart Cassette only way
	TCB-GFC1602UE	✓	✓				Fresh air filter chamber	4-way standard cassette only
	TCB-SP1603UE	✓					Spacer for height adjustment	4- Smart Cassette only way
	TCB-SP1602UE	✓	✓				Spacer for height adjustment	4-way standard cassette only
	TCB-BC1603UE	✓					Air discharge direction kit	4- Smart Cassette only way
	TCB-BC1602UE	✓	✓				Air discharge direction kit	4-way standard cassette only
	TCB-FF101URE2	✓	✓				Auxiliary fresh air flange	4-way smart cassette, 4-way standard cassette, compact cassette, slim duct
	TCB-SF56C6BPE	✓	✓				Spigot shaped flange	Suitable for RAV-SM40#/56#BTP-E1-MMD-AP007#/018-HP1-E
	TCB-SF80C6BPE	✓	✓				Spigot shaped flange	Suitable for RAV-SM80#BTP-E1-MMD-AP024#/030#BHP1-E
	TCB-SF160C6BPE	✓	✓				Spigot shaped flange	Suitable for RAV-SM110#/160#BTP-E1-MMD-AP036#/056#BHP1-E

Note: ² Check with Technical for Compatibility - For additional control options contact Cool Designs Technical Support.

NOTES

Features

- ⇒ 2 wire, screened, non-polarised controller connection
- ⇒ Infrared control available for cassette, under ceiling, high wall, ducted models
- ⇒ Remote temperature sensing available, Unit, Wired controller, Separate room sensor
- ⇒ Automatic addressing of groups and twins
- ⇒ Optional control of external fan, (RBC-SMF1)
- ⇒ High ceiling compensation (code 5d)
- ⇒ Time for filter warning is configurable (code 01)
- ⇒ Each mode of operation (auto – heat – cool – dry) may have a different temperature set point
- ⇒ Auto restart is configurable (code 28)

Cassette PCB

- ⇒ DC fan motor with feedback circuit
- ⇒ Red LEDs indicate communication with local controller and PCB activity when illuminated.
- ⇒ Wired or infrared control (or both)
- ⇒ Drain pump and float switch

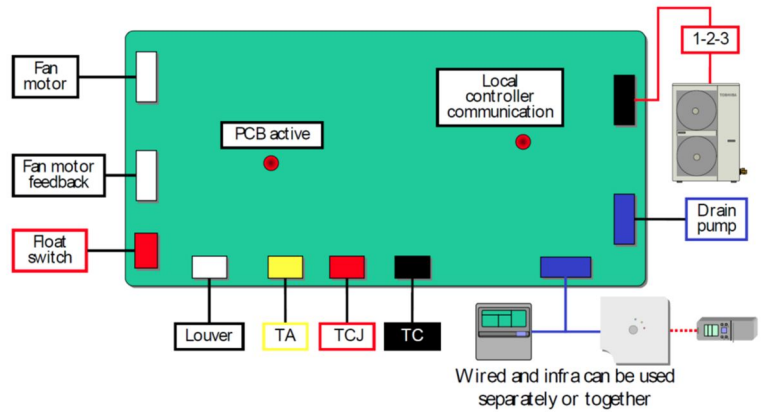

Wired controller (RBC-AMT32/41)

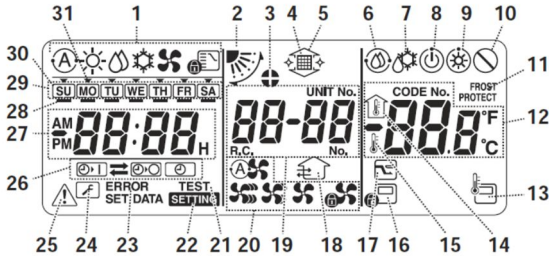

- | | | |
|------------------------|------------------------------|---------------------------|
| 1. Mode of operation | 11. Frost protection | 21. TEST |
| 2. Louver | 12. Numeric display | 22. Setting |
| 3. Fixed louver | 13. Remote controller sensor | 23. Error |
| 4. Filter | 14. Not used | 24. Servicing |
| 5. Not used | 15. Set Temperature | 25. Inspect |
| 6. Self-clean function | 16. Central control | 26. Timer function |
| 7. Defrosting | 17. Save Operation | 27. Numeric display |
| 8. Ready | 18. Ventilation operation | 28. Operation reservation |
| 9. Heating ready | 19. Numeric display | 29. Days of the week |
| 10. Not used | 20. Air speed | 30. Special holiday |

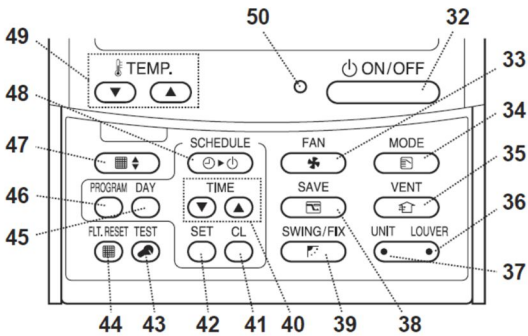

- | | |
|----------------------|-------------------------|
| 32. On/OFF button | 42. Set button |
| 33. Fan button | 43. Test button |
| 34. Mode button | 44. Filter reset button |
| 35. Vent button | 45. Day button |
| 36. Louver button | 46. Program button |
| 37. Unit button | 47. Grille button |
| 38. Save button | 48. Schedule button |
| 39. Swing/Fix button | 49. Temperature buttons |
| 40. Time button | 50. ON/OFF Light |
| 41. Clear button | |

Wired controller (RBC-AMS55E-ES)

Standard Display

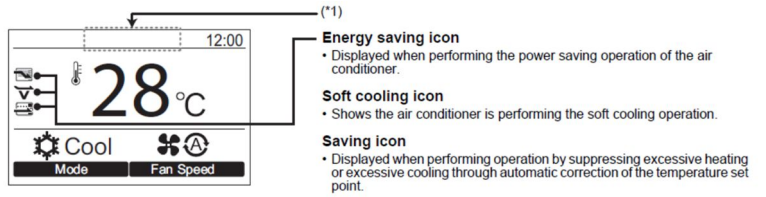

Detailed Display

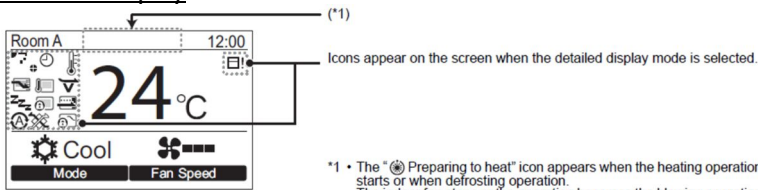

Icon List

	Shows the Energy saving operation is activated. (page 28)		Shows a timer function is activated. (page 19, 21)
	Shows the remote sensor is activated. (*2)		Shows the Louver lock is activated. (page 18)
	Shows the Night operation is activated. (page 25)		Shows the setting of the louver. (page 13, 14)
	Shows the central control device prohibits the use of the remote controller (page 47)		Shows the filter needs to be cleaned. (page 26, 48)
	Shows the saving operation is activated. (page 33)		Shows soft cooling is activated. (page 41)
			Shows operation switching control is in progress.

Buttons

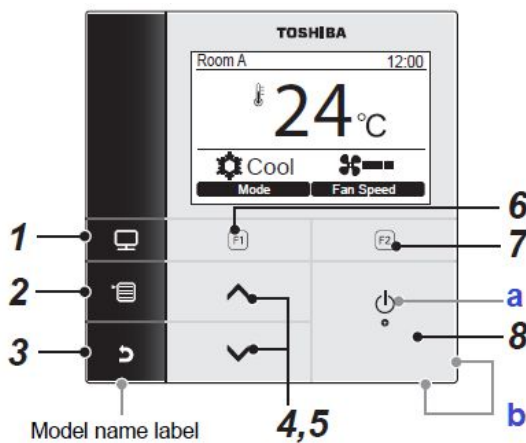

- 1 Monitor button
- 2 Menu button
- 3 Cancel (Back) button
- 4-5 Temperature buttons
- 6 F1 function button
- 7 F2 function button
- 8 Power button (On/Off)
- a LED illuminated when unit is on
- b Temperature sensor

Group control

- Indoor units may be supplied from any phase.
- Up to 8 indoor units per group.
(When TCB-TC41LE remote temperature sensor/ second remote controller is added to a "Group" the quantity of indoor units drops from 8 to 7.)
- Automatic addressing.
- Any indoor unit may be designated as the "Lead Unit".
- Pre-heat indication.
- Filter indication.

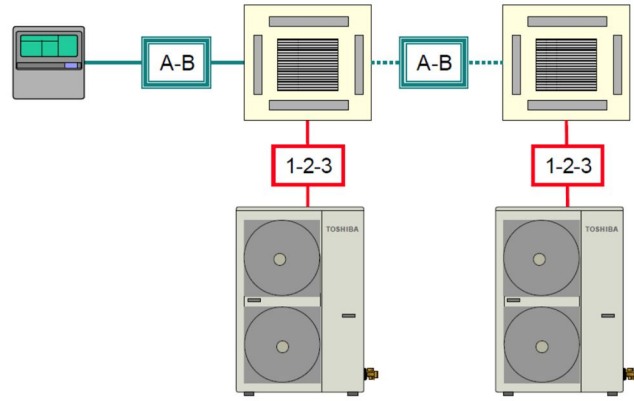

Automatic addressing

This takes place when power is applied and can last up to 5 minutes – the address will be selected automatically.

If a replacement indoor PCB is fitted, the missing address will be re-applied.

The powered controller screen shows the demarcation lines – and does not indicate that the system is either configuring itself – or is ready to use. If the remote temperature sensor is selected (configuration item 32), the associated symbol will appear when the system is ready for use. If a 9th indoor unit (which can be a protocol converter) is added to a group, the controller will continue to show the demarcation lines.

Adding a system to an existing group (or powering a group up at different times) will require manual configuration (the fault codes will provide guidance).

Identifying an indoor unit

- Stop operation
- Press **TEST** (43) and **VENT** (35) for 4 seconds
- ALL is displayed
- Indoor fans of the entire group are now energised
- Press **UNIT** (37) to scroll through group
- Indoor fan of selected indoor unit runs
- Press **TEST** (43) to exit.

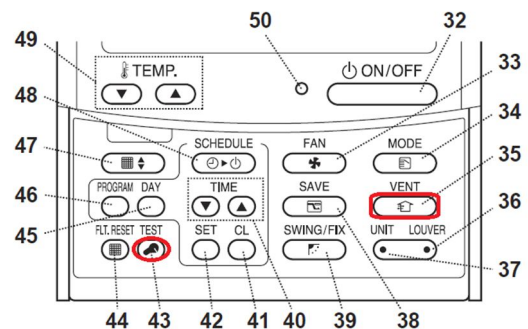

Test operation

- System must be stopped
- Press **TEST** (43) for 4 seconds
- Controller displays TEST
- Press the **ON/OFF** (32) button to start operation
- Select **MODE** (34) of operation
- HEAT or COOL
- Press the **ON/OFF** (32) button to stop test
- System will automatically revert to normal operation after 1 hour
- Press the **TEST** (43) button to leave TEST function

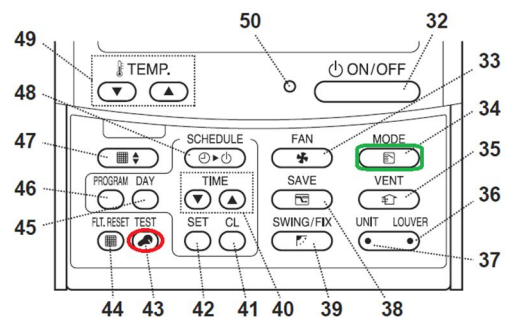

Controller Configuration - Remote Controller RBC-AMT32E & RBC-AMS41E

Quick Reference Guide

To assist service engineers working on Toshiba air conditioning equipment, there is a large quantity of data available via the standard remote controller, either the RBC-AMT32E or the RBC-AMS41E, this data is **NOT** available via an Infrared remote or the RBC-AS21E2 simplified remote controllers.

Accessing the data is a simple process of pressing a sequence of buttons on the remote controller.



Fault Code Guide

Current fault codes are displayed automatically on the left of the remote controller, (Four figure display in Black) fault code history can be accessed by pressing "**TEST & SET**" together and holding for 4 seconds. Each controller will hold four fault codes per unit controlled, the first displayed fault code is the youngest and the fourth will be the oldest. To scroll through the fault's, use the "**TEMP▲▼**" buttons.

▪ **Refer to the Technical Handbook for fault code diagnosis and descriptions**



System Data

System data can be obtained by pressing "**TEST & CL**" together and holding for 4 seconds. Codes are displayed on the right of the remote display.

To scroll through the codes use the "**TEMP▲▼**" buttons. Data is displayed on the left of the remote controller. Data is available for "0, 1, 2, 3 & 4 Series" Digital/Super Digital inverter and VRF equipment (Mini SMMS, SHRM, SHRMi, SMMS & SMMSi).

Controller Configuration - Remote Controller RBC-AMS51/54/55E-ES

Quick Reference Guide

To access this section on the RBC-AMS51/54/55E-ES



Fault Code Guide

Current fault codes are displayed automatically on the top of the remote controller, (four figure display in Black) fault code history can be accessed by entering the "field Setting Menu"

Press and hold the "**[MENU]**" button and the "**[▼]**" button at the same time for more than 4 seconds to display the "**Field setting menu**" scroll down to "Alarm History". The history holds 10 fault codes per unit controlled.

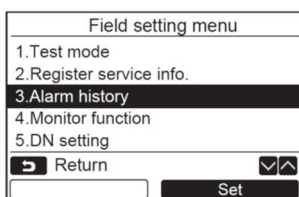

System Data

System data can be obtained by entering the "Field Setting Menu" and scroll down to "Monitor Function"

When in monitor mode scroll through the data using the up/down buttons.



System Data

System data can be obtained by pressing "**TEST & CL**" together and holding for 4 seconds. Codes are displayed on the right of the remote display.

To scroll through the codes, use the "**TEMP▲▼**" buttons. Data is displayed on the left of the remote controller. Data is available for "0, 1, 2, 3 & 4 Series" Digital/Super Digital inverter and VRF equipment (Mini SMMS/e, SHRM, SHRMi, SHRMe, SMMS, SMMSi & SMMSe).

Data Retrieval Guide - [Remote Controllers RBC-AMT32E, RBC-AMS41E & RBC-AMS51/54 / 55E-ES](#)

Digital/Super Digital "1" Series R32

Code	Indoor Data	Code	Outdoor Data
00	Room Temp (Control Temp) (°C)	60	TE Sub-cooled Liquid Temp (°C)
01	Room Temp (Remote Controller) (°C)	61	TO Ambient Temp (°C)
02	TA Return Air Temp (°C)	62	TD Discharge Temp (°C)
03	TCJ Coil Liquid Temp (°C)	63	TS Suction Temp (°C)
04	TC Coil Vapour Temp (°C)	65	THS Inverter Heat Sink Temp (°C)
07	Fan Speed (rpm)	6A	Operation Current (x1 1/0) (A)
F2	Fan Run Time (x 100h)	6D	TL Liquid Temp (°C)
F3	Filter Duration Timer (x 1h)	70	Compressor Frequency (rps)
		72	Fan Speed (Lower) (rpm)
		73	Fan Speed (Upper) (rpm)
		F1	Compressor Run Time (x 100h)

NOTES

Network Addressing DI/SDI

Terminology

Terms for explaining DI/SDI used in section are redefined to:-

- Indoor Unit No. N-n =outdoor unit line address N (Max30) –indoor unit address n (max64)
 Group address 0=single (not group control)
 1=Lead unit in group control
 2=sub unit in group control

Lead unit:

The representative of multiple indoor units in group operation sends/receives signal to/from the remote controllers and sub indoor units. It has no relation with an indoor unit which communicates serially with the outdoor units. Also this unit communicates with the central controller. The operation mode and setup temperature range are reflected on the remote controller LCD. (Except air direction adjustment of louver)

Sub unit:

Indoor units other than master unit in group operation. Basically, sub units do not send/receive signals to/from the remote controller.

Header unit (Representative unit) (Master twin):

This unit communicates with the indoor unit (follower) which serial-communicates with the outdoor units and sends/receives signal (command from compressor) to/from the outdoor units as the representative of the cycle control in the outdoor units of the identical line address within the minimum unit which configures one of the refrigerating cycles of twin.

Follower unit (Subordinate unit) (Sub twin):

Indoor units excluding the header unit in Twin. This unit communicates with Header indoor unit in the identical line address and performs control synchronized with Header unit. This unit does not perform the signal send /receive operation with the outdoor units. No judgement for serial signal error.

Basic configuration

The basic DI/SDI connection configuration of each type of model is shown below.

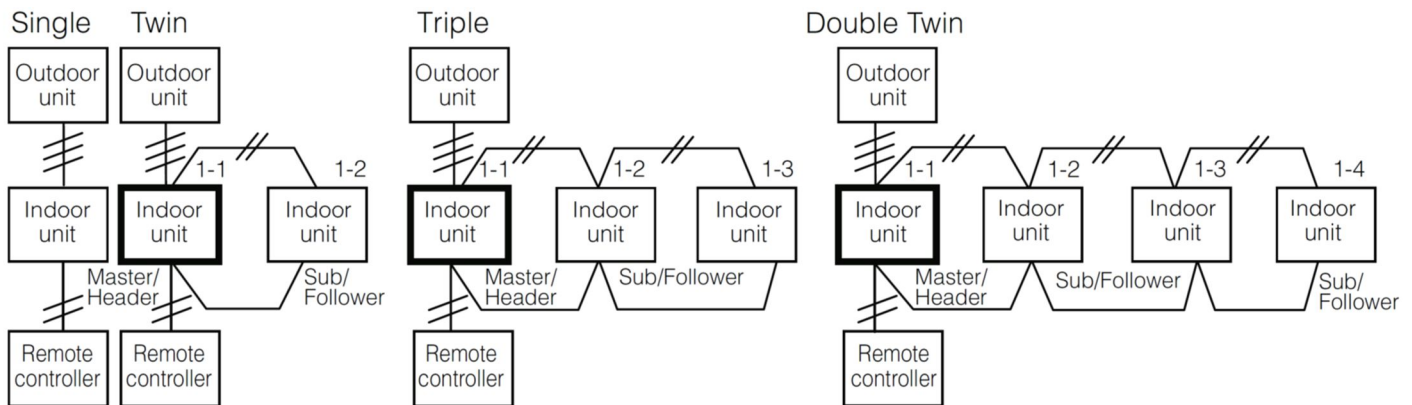

Address re-setup for group control

After turning on the power and finishing automatic address setting, check the Indoor Unit No using the wired remote controller. If the line address is not unified in the devices in a refrigerant line, unify the line address using the wired remote controller. If group control is used, assign the group address "1" to any one of the indoor units and "2" to the rest of the units. Confirm that each indoor unit in a group has a unique Indoor Unit No (E08 error is not indicated on the wired remote controller).

Standard configuration (One outdoor unit)

In this case, address setting can be made by using auto addressing.

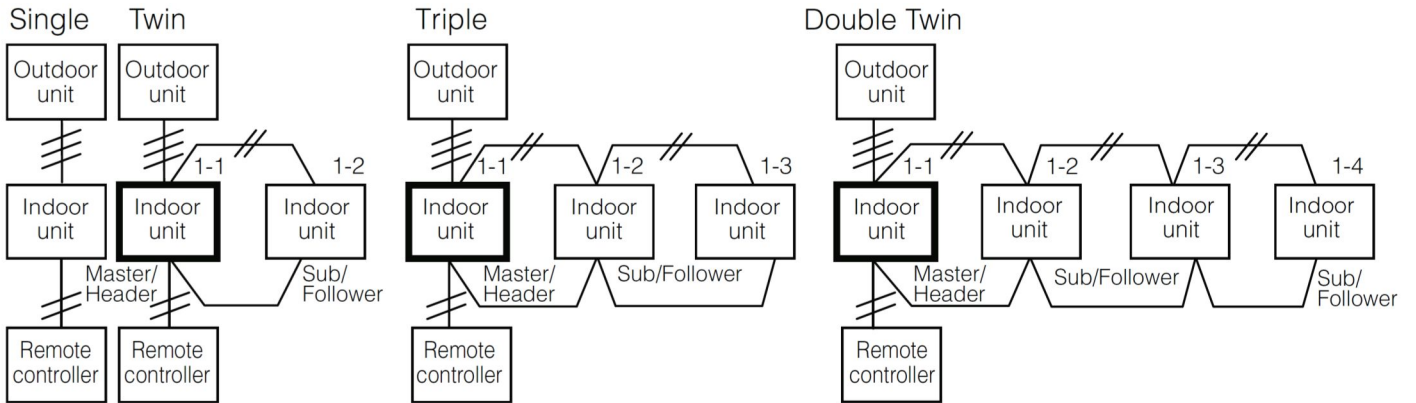

Group configuration (single only)

In this case, address setting can be made by using auto addressing.

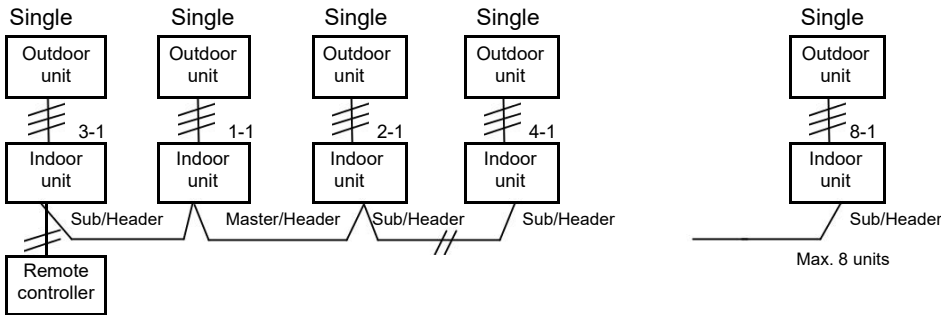

Multiple Group configuration (combination of single/twin/triple)

In this case, manual re-addressing is required.

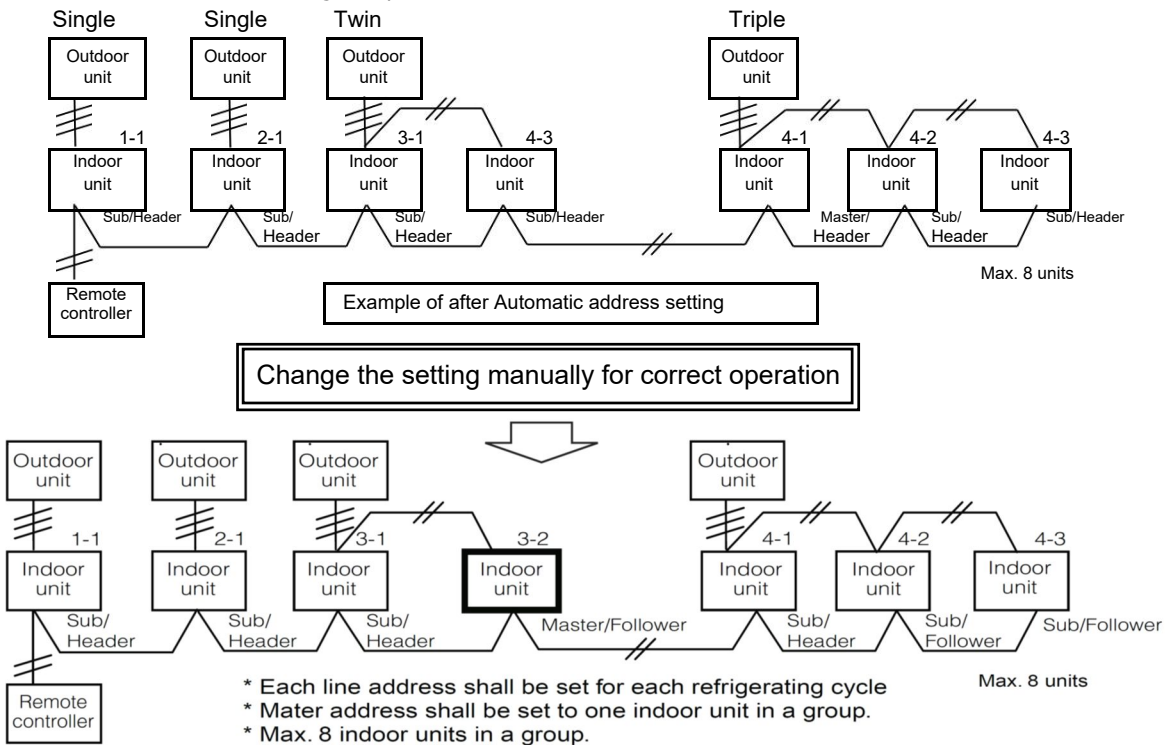

Network Addressing DI/SDI

Connection and Address re-setup example for central control

“1:1Model” Connection Interface TCB-PCNT30TLE2

When controlling the super-digital inverter and the digital inverter, the adaptor named “1:1 model” connection interface (TCB-PCNT30TLE2) is necessary.

SDI series 4 4-way discharge cassette type, etc. need metal case TCB-PX30MUE additionally for fixing. Some of Hi-wall Type does not need “1:1Model” Connection Interface. Please refer to installation manual of each model.

Cabling connection of control wiring

Attach an adaptor per 1 group in the group control operation (including individual control).
Connect the adaptor to the Master indoor unit in the group control.

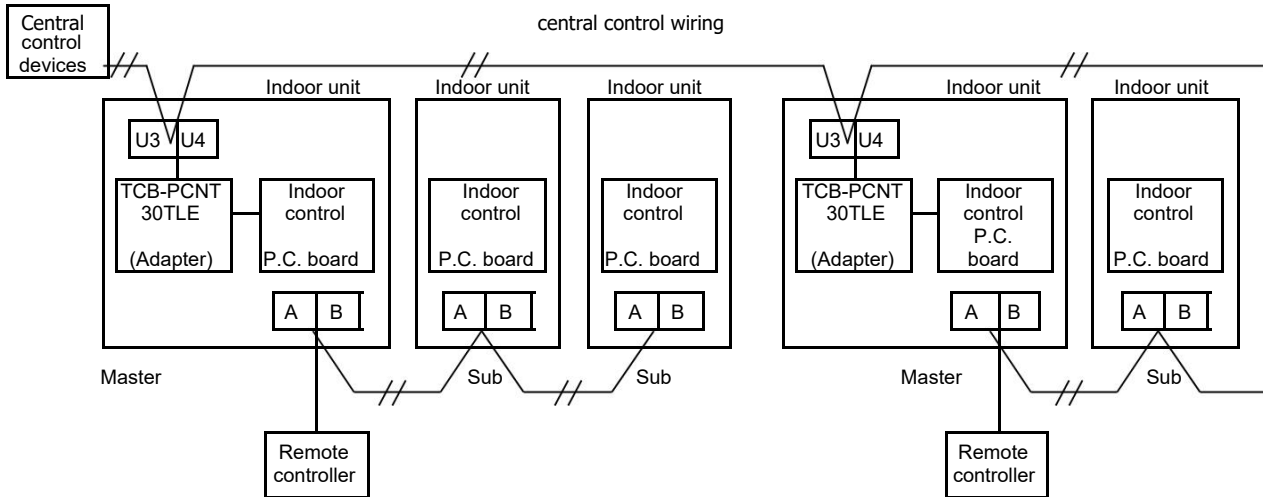

A central control connection example of a system where both VRF and DI/SDI are used is shown below. The VRF and DI/SDI subsystems are connected through the central control wiring and to the central control devices.

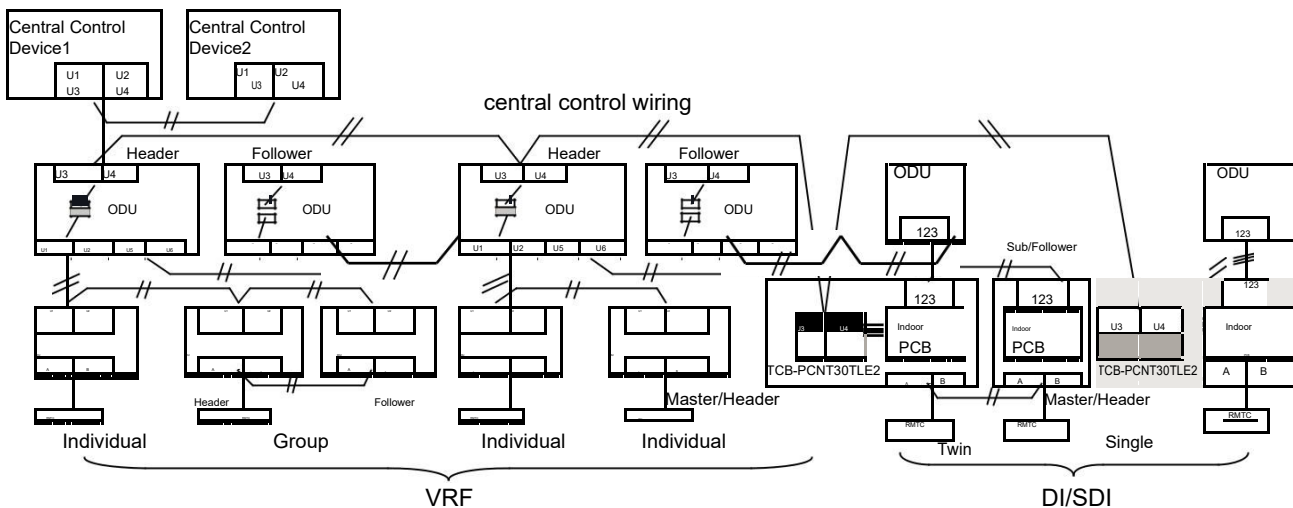

Network Addressing DI/SDI and VRF Systems

When the central control is performed for indoor units using twin control in a group operation, it may be required to change the group address. (Adapter is attached to the Lead indoor unit.)

Reason: The central control device communicates with each individual indoor unit, the Lead indoor unit of the group control and the Lead indoor unit of the twin control. However, as the address is automatically set up, which unit will become the Lead unit is indefinite. Therefore, if the unit attached with adapter does not become the Lead indoor unit, the central control function will become unavailable.

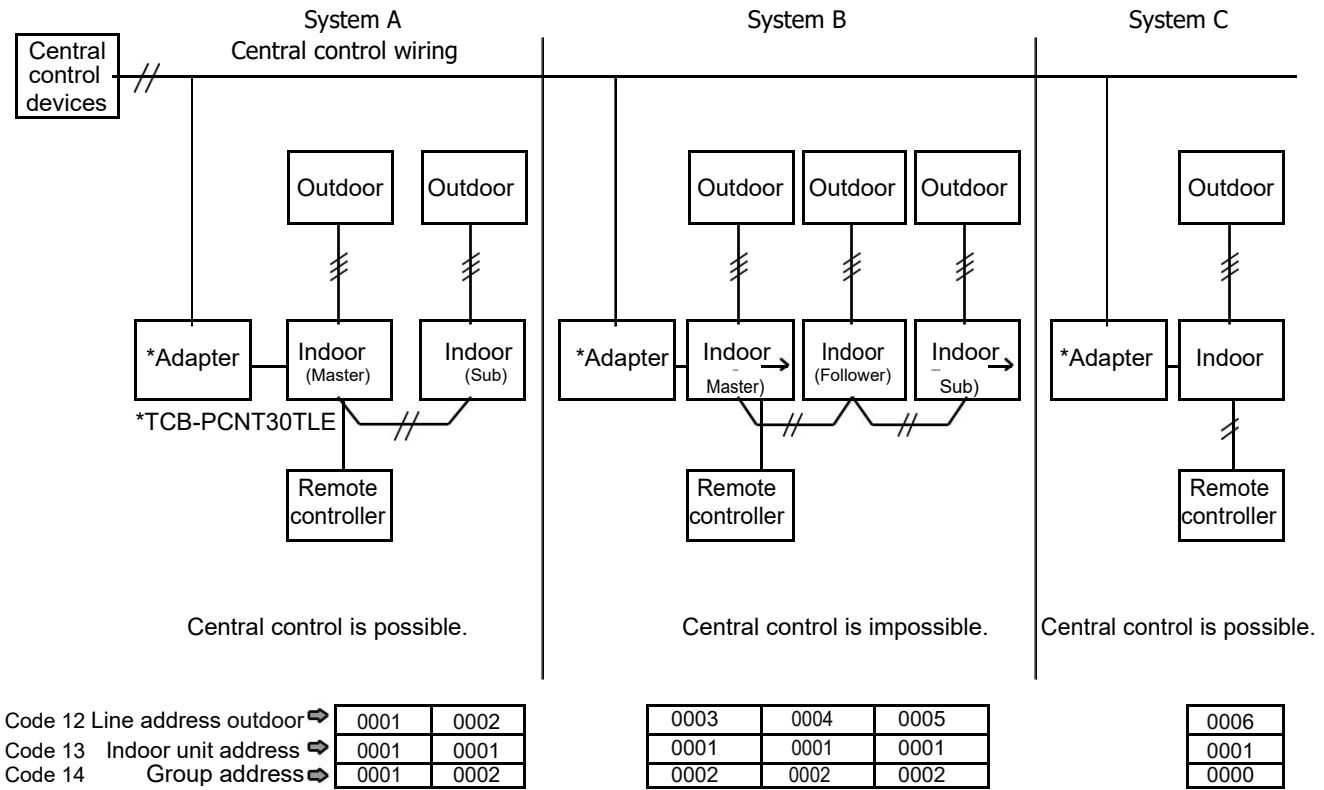

***A wired remote controller (RBC-AMT32E, RBC-AMS41E, RBC-AMS51/54/55E-ES.) is required for address change.**

Address setup procedure (when using DI/SDI only, or using DI/SDI and VRF)

When an outdoor unit and an indoor unit are connected, or when an outdoor unit is connected to each indoor unit respectively in the group operation even if multiple refrigerant lines are provided, the automatic address setup completes with power -ON of the outdoor unit after group construction check (refer to the note below). The operation of the remote controller is not accepted while automatic address works. (Approx.4 to 5 minutes)

CAUTIONS

1. Set up address after the wiring has been completed.
2. "1:1Model" Connection Interface TCB-PCNT30TLE2 is necessary for DI/SDI for central control. Some Hi-wall Type do not need "1:1Model" Connection Interface. Please refer to the installation manual of each model. Connect the central control devices to U3/U4 wires of the central control system.
3. When "1:1Model" Connection Interface is used for the group control or twin, triple or quad system, the interface must be connected to the Master unit of the indoor unit. (Connection to Sub unit is unavailable). One "1:1Model" Connection Interface per one group.
4. In group operation, be sure to turn on power supplies to all indoor units in group control within 3 minutes. When power supply of the Master unit is not turned on, there is a possibility that the Master unit exchanges with Sub unit. (If Master unit is exchanged, the central control is unavailable.)

Note)

If group construction is abnormal, the automatic address sequence starts automatically. Normal condition is below.

1. There is no duplicated indoor unit address.
2. There is no invalid indoor unit address.
3. Individual unit and master/sub units are not intermingled.
4. Only a unit for Individual.
5. A master indoor unit and 1 or more sub indoor units for group.

Integration with AI Network Control

TCC-net models use a different language to AI – however a TCC-net group can be linked to an AI network, using a protocol converter. This device is not standard and should be fitted on site – a group requires only one protocol converter to communicate with a network.

An LED flashes to indicate communication with the network.

The Protocol converter provides terminals X-Y for the network connection – it also has the 7-way DIP switch used to give a network address – the method is identical to that used for AI indoor units.

The network address may also be set by a wired controller from the configuration menu.

The protocol converter is counted as an indoor unit – only 7 indoor units may therefore be group controlled in this way.

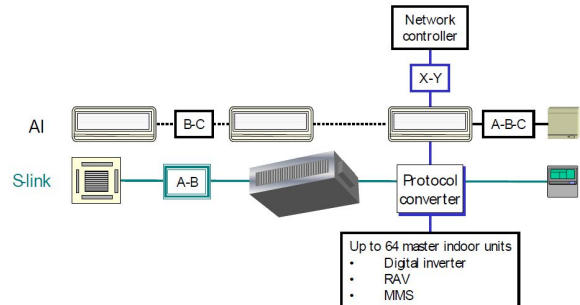

Second Controller

- ⇒ Options available
 - 2 x wired controllers
 - 1 wired + 1 infrared controller
- ⇒ Full group control from either
- ⇒ Connection may be anywhere within group
- ⇒ Changes updated

The sub-controller must be set – this can be done from either controller. The choice of sub-controller makes little difference unless it is required to act as the temperature sensor

Temperature Sensing

Wired controllers are able to supply a temperature value to the indoor unit. This may be more representative than the standard, return air sensor but is not available from sub controllers of either type. To set the room sensor:

- ⇒ Wired controller – selected from configuration menu code "32" (0001), or via the "bit switch 4" on the RBC-AS41 simplified remote.

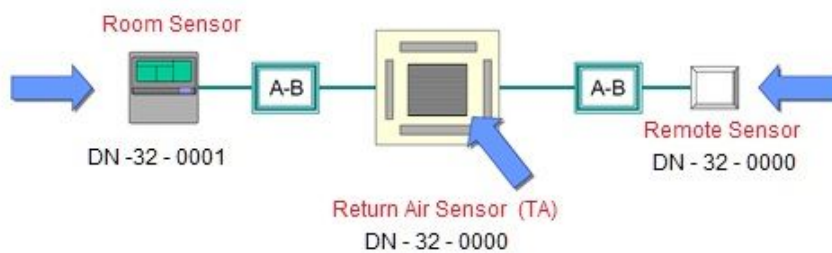

The remote sensor. This is connected to terminals A-B whether or not a wired controller is used. The indoor unit must, in this case, be set to use the standard, return air sensor (Configuration code "32" - 0000), – this sensor automatically takes over in this case. This value will be used to provide control to all indoor units within the group.

NOTES

Additional “Pocket Quick Reference Guides” are available covering;

Pocket Handbook R32 AC Products.
VN-M (HE & HE1) Units, Air to Air Heat Exchangers.
RBC-AMT32 Standard Wired Remote Controller.
AMS41E Wired Remote Controller with 7-day timer.
RBC-AMS51/54/55E-ES Back Light Wired Remote Controller with 7-Day
Timer.
RBC-ASC11E Compact Simple Controller.
RBC-MTSC1 Mini Touch Screen
R410A VRF Addressing / Commissioning.
R410A SMMSe Heat Pump Calculating the Refrigerant Charge.
R410A SHRMe Heat Recovery Systems.
R410A Single Fan Mini VRF.
FPD3 – Full AHU Control Interface.
FDP3 – Modbus AHU Control Interface.
RBC-RASNC – RAS Central Controller Interface.
CDL-VN-M CO2 Kit.
CDL-BMS01 Interface.
WIFI options Interface and “Applications”.

Future Publications coming soon.

RBC-TBPTS Colour Smart Touch Screen Central Remote Controller.
RBC-TSI1 Universal Monitoring and Control Interface including Modbus.
RBC-IS-IR-WIFI-1 Intensishome WIFI Universal Controller.
RBC-TO-RC-Wifi-1 Intensishome WIFI Toshiba RAV/VRF.

You will also find Single Sheet Literature for all the current Toshiba Air Conditioning Units on our web site, along with Installation, Owners and Service manuals.

<http://www.cdlweb.info>

Contact details:

Cool Designs Ltd
Technical Support
07590 775510 / 07706 293028
Monday – Friday 07.30 to 19.30

Email: support@cooldesignsltd.co.uk
Web site: www.cdlweb.info

TOSHIBA Air Conditioning
24/7 technical support
0870 843 0333 (Option 7)

Text back service
07624 803 017
(Type fault code in lower case no spaces)



Try our on-line training videos on YouTube.

Cool Designs Ltd reserves the right to change the product specifications, data and images without notice



Cool Designs Ltd

Raising the Standards in Air Conditioning Distribution