

Horizontal Bulkhead Unit (built-in drain pump) Only 450mm deep



ARXK07/09/12GCLH

Compact & Slim horizontal Bulkhead indoor unit ideal for Hotel rooms & residential spaces

Feature

Feature

Reduced depth

Installation space can be reduced down to minimum depth 600mm height 223mm and larger living space can be realised.

Static Pressure
Max. **30 Pa**
(07 / 09 / 12)

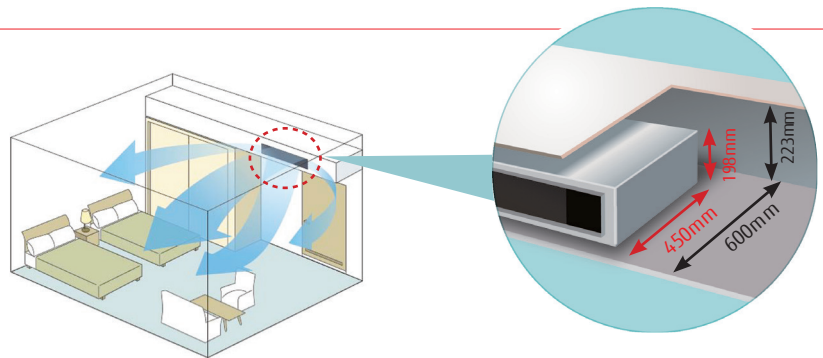

Feature

Optimum airflow path and low noise operation

Low noise is realized drastically by stabilized airflow design

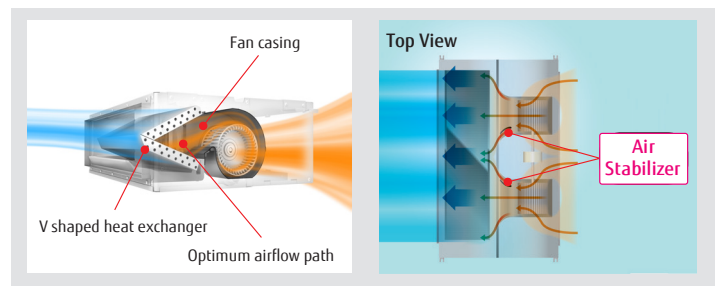

Feature

Easy design and maintenance for drain

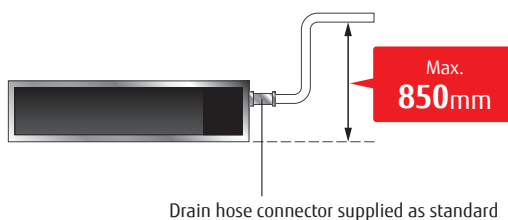

Models with drain pump: Maintenance is easy

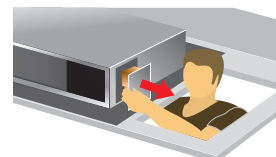

Parts can be replaced from the side of the body where maintenance is easier

Optional parts

Auto Louver (option)

- Thin design provides a comfortable living environment over a wide area.
- Automatic louver grille provides comfortable air conditioning all the way down to the floor and matches the interior design well.



- IR receiver unit** : UTB-YWC
Auto louver grille kit : UTD-GXTA-W (ARXK07/09/12GCLH)
Remote sensor unit : UTY-XSZX
External connect kit : UTY-XWZXZ7
 : UTY-XWZXZB
 : UTY-XWZXZC
 : UTY-XWZXZD
 : UTY-XWZXZE

Dimensions

(Unit:mm)

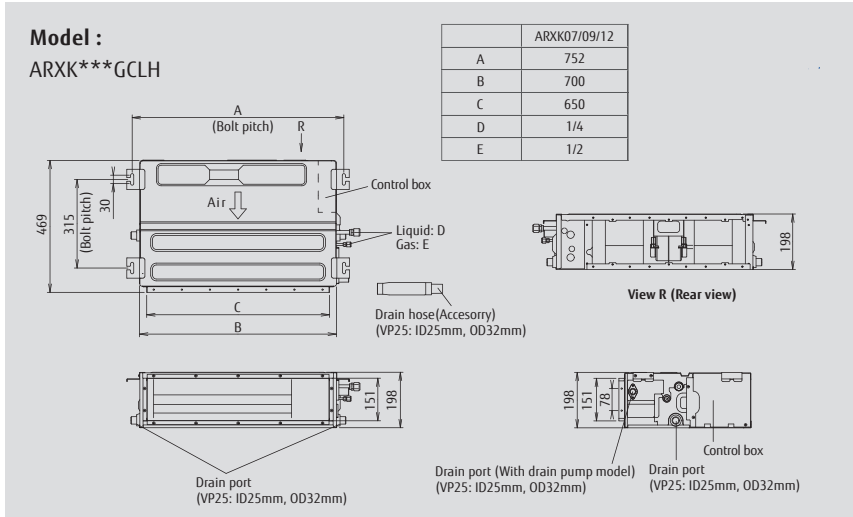

Compatibility

VRF Series	Available
<i>AIRSTAGE J-III</i>	✓
<i>AIRSTAGE J-II / J-III</i>	✓
<i>AIRSTAGE V-II</i>	✓
<i>AIRSTAGE V-III</i>	✓
<i>AIRSTAGE VR-II</i>	✓

Specifications

Model name			ARXK07GCLH	ARXK09GCLH	ARXK12GCLH
Power source		V/∅/Hz	230V / 1 / 50Hz		
Capacity	Cooling	kW	2.2	2.8	3.6
	Heating		2.8	3.2	4.0
Input Power		W	28	28	35
Airflow rate	High	m ³ /h	460	460	550
	Me-Hi		440	440	520
	Med		420	420	480
	Lo-Hi		400	400	450
	Low		370	370	410
Static pressure	Range	Pa	0 to 30	0 to 30	0 to 30
	Standard		10	10	10
Sound pressure level	High	dB(A)	26	26	29
	Me-Hi		25	25	27
	Med		24	24	26
	Lo-Hi		23	23	25
	Low		22	22	24
Dimensions (H x W x D)		mm	198 × 700 × 450	198 × 700 × 450	198 × 700 × 450
Weight		Kg	15.5	15.5	16
Connection pipe diameter	Liquid		1/4	1/4	1/4
	Gas	mm	1/2	1/2	1/2
	Drain hose		VP25 [φ25(I.D.) ; φ32(O.D.)]		

Note : Specifications are based on the following conditions.

Cooling : Indoor temperature of 27°CDB / 19°CWB, and outdoor temperature of 35°CDB / 24°CWB.

Heating : Indoor temperature of 20°CDB / (15°CWB), and outdoor temperature of 7°CDB / 6°CWB.

Pipe length : 7.5 m; Height difference between outdoor unit and indoor unit : 0m. Voltage : 230 [V].



**AIRSTAGE*™ are worldwide trademarks of FUJITSU GENERAL LIMITED and are registered trademarks in Japan and other countries or areas.

• Other company and product names mentioned herein may be registered trademarks, trademarks or trade names of their respective owners.



• Specifications and design are subject to change without notice for further improvement.
 • Actual products' colors may be different from the colors shown in this printed material.

Distributed by :

FUJITSU GENERAL AIR CONDITIONING (UK) LTD

Unit 150 Centennial Park, Centennial Avenue, Elstree, Herts. WD6 3SG
 www.fujitsu-general.com/uk

Tel: +44 (0)208 731 3450 Fax: +44 (0)208 731 3451

Copyright© 2016 Fujitsu General Limited. All rights reserved. 3EFNP10-1510E