

## Toshiba Air Conditioning - RAS Data Sheet

### RAS-18PKVSG-E Shorai High-Wall Inverter

#### Features

- Designed for use with refrigerant R32
- Class-leading energy saving
- Extremely low sound levels
- Capacity booster to reach comfort setpoint very quickly
- Power change button to reduce power consumption by up to 25%
- Self-cleaning function



#### Technical Data

Model reference indoor unit		RAS-18PKVSG-E
Nominal cooling	kW	5.00
Nominal heating	kW	6.00
UK cooling	kW	4.88
UK sensible cooling	kW	3.57
UK heating	kW	3.83
Air flow (high/low)	m <sup>3</sup> /h	950/499
Sound pressure (high/low)	dB(A)	44/31
Dimensions (H x W x D)	mm	320 x 1050 x 250
Unit weight	kg	14
Model reference outdoor unit		RAS-18PAVSG-E
Maximum run current	A	8.05
Suggested fuse size	A	16
Power supply	V-ph-Hz	220/240-1-50
Interconnecting cable		3-core + earth
Sound pressure (cool/heat)	dB(A)	49/50
Air flow (high)	m <sup>3</sup> /h	2076
Dimensions (H x W x D)	mm	550 x 780 x 290
Unit weight	kg	34
Pipe sizes (liquid-suction)	inch	1/4-1/2
Maximum pipe length/height difference	m	20/12
Pre-charge pipe length	m	15
Additional refrigerant - factory charge	g/m - kg	20 - 1.10
EER/COP		3.52/3.75
SEER/SCOP		7.30/4.40

#### Dimensional Drawings

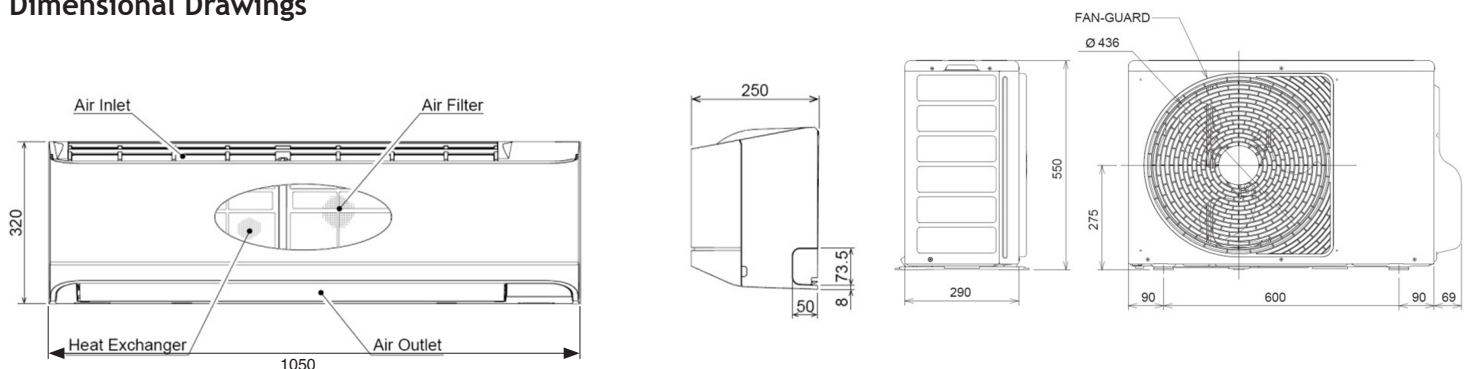

Cool Designs Ltd

Raising the Standards in Air Conditioning Distribution

www.cdlweb.info

