

## Toshiba Air Conditioning - RAV-GP Data Sheet

### RAV-GP1101AT-E Outdoor Unit

#### Features

- Redesigned for use with refrigerant R32
- Wide operating range (cooling mode -15°C to +52°C)
- Auto-diagnostic function
- Flexible, can be utilised for single, twin, triple indoor applications
- Compact size



#### Technical Data

Model reference		RAV-GP1101AT-E	
Nominal	Cooling Capacity	kW	10.0
	Heating Capacity	kW	11.2
Operating Range	Cooling/Heating	°C	-15 to 52/-27 to 15
Air Flow	High	m³/h - l/s	6960 - 1934
Sound	Pressure High Cooling/Heating	dB(A)	49/50
	Power High Cooling/Heating	dB(A)	66/67
Unit	Height x Width x Depth	mm	1550 x 1010 x 370
	Weight	kg	104
Pipe Connection	Flare Connections (gas - liquid)	inch	5/8 - 3/8
	Min. -Max. Length	m	3-75
	Maximum Height Difference	m	±30
	Drain Port Connection	mm	16
Refrigerant R32	Base Charge/Chargeless Length	kg/m	3.1/30
	Additional Charge Liquid Side	g/m	35
Run Current	Maximum	A	10.43
Power Cable	Outdoor to Indoor		3 core + earth
Power Supply	Suggested Fuse Size	V/ph/Hz-A	220-240/1/50-20

#### Dimensional Drawings

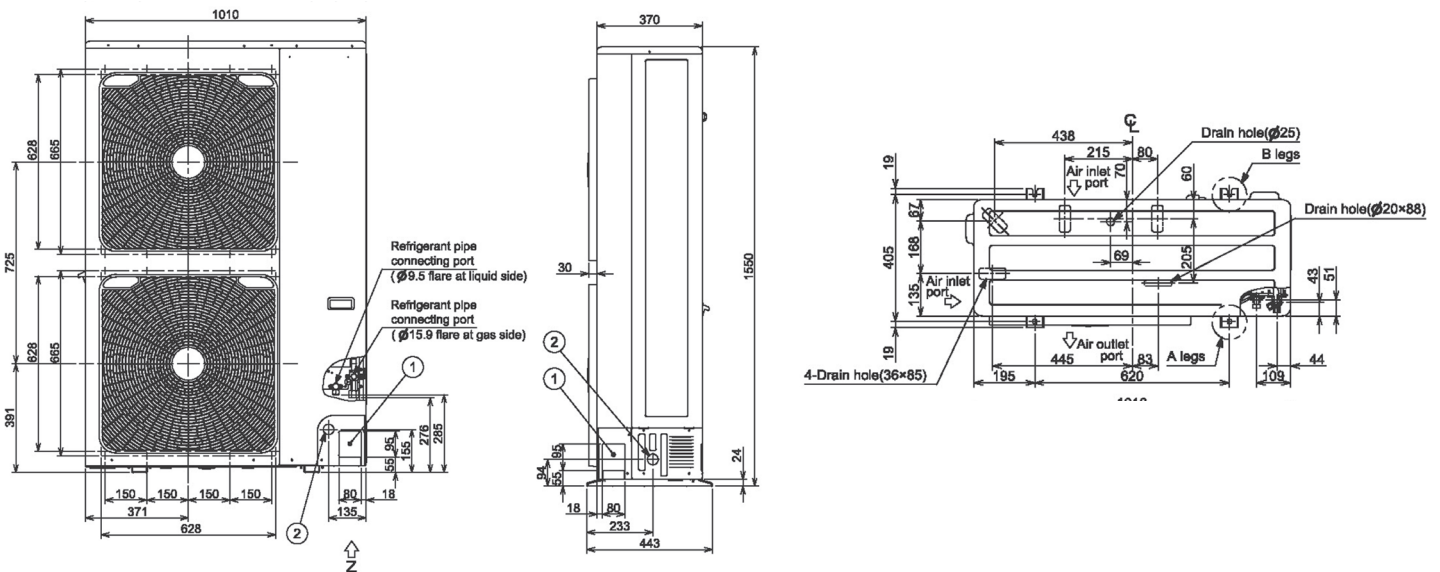

Cool Designs Ltd

Raising the Standards in Air Conditioning Distribution

www.cdlweb.info

