

## Toshiba Air Conditioning - RAS Data Sheet

### RAS-3M26U2AVG-E Multi-Split Outdoor Unit

#### Features

- Wide range of indoor units available for use with refrigerant R32
- Wide operating range (cooling mode -10°C to +46°C)
- Vertical pipe lengths up to 15 metres
- Compact size
- Superior reliability due to Toshiba's unique inverter compressor



#### Technical Data

Model reference		RAS-3M26U2AVG-E
Nominal cooling	kW	7.5
Nominal heating	kW	9.0
Sound power (high)	dB(A)	64
Sound pressure (high)	dB(A)	49
Dimensions (H x W x D)	mm	890 x 900 x 320
Unit weight	kg	72
Power supply	V-ph-Hz	220/240-1-50
Interconnecting cable per indoor unit		3-core + earth
Suggested fuse size	A	16
Maximum operating current (cooling)	A	11.67
Operating range, cooling	°C	-10-46
Operating range, heating	°C	-15-24
Minimum number of indoor units		2
Maximum number of indoor units		3
Pipe sizes, unit A (liquid-suction)	inch	1/4-1/2
Pipe sizes, unit B (liquid-suction)	inch	1/4-1/2
Pipe sizes, unit C (liquid-suction)	inch	1/4-3/8
Pipe lengths per unit (min./max.)	m	3-25
Maximum pipe length	m	70
Maximum height difference	m	15
Pre-charge pipe length	m	40
Additional refrigerant - factory charge	g/m - kg	20 - 1.92

#### Dimensional Drawings

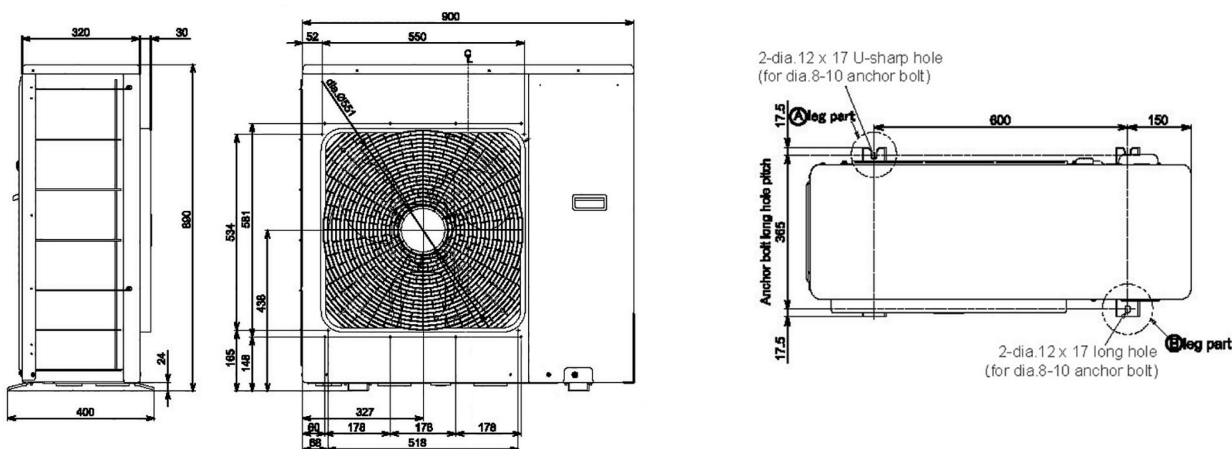

Cool Designs Ltd

Raising the Standards in Air Conditioning Distribution

www.cdlweb.info

