

Toshiba Air Conditioning - RAV-RM Data Sheet

RAV-RM1101UTP-E 4-Way Cassette

Features

- Redesigned for use with refrigerant R32
- Self-cleaning function
- Lift pump up to 850 mm lift
- Individual setting of louvre position
- Wireless remote control and optional wired remote controller and timer



Technical Data

Model reference			RAV-RM1101UTP-E
Nominal	Cooling Capacity	kW	9.5
	Heating Capacity	kW	11.2
	EER/COP	W/W	3.31/3.82
UK	Cooling Total/Sensible	kW	9.10/7.56
	Heating	kW	8.01
Cooling EN14825	Range Min. - Max.	kW	3.0 - 11.2
	Power Input	kW	2.87
	Pdesign	kW	9.5
	SEER/Energy Efficiency Class		6.15/A++
	Seasonal Energy Consumption	kWh/a	597
Heating EN14825	Range Min. - Max.	kW	3.0 - 13.0
	Power Input	kW	2.93
	Pdesign	kW	8.0
	SCOP/Energy Efficiency Class		4.28/A+
	Seasonal Energy Consumption	kWh/a	2616
Air Flow	High - Medium - Low	l/s	558 - 400 - 325
	High - Medium - Low	m ³ /h	2010 - 1440 - 1170
Sound	Pressure High - Medium - Low	dB(A)	43 - 38 - 33
	Power High - Medium - Low	dB(A)	58 - 53 - 48
Unit	Height x Width x Depth	mm	319 x 840 x 840
	Weight	kg	24
Panel	Height x Width x Depth	mm	30 x 950 x 950
	Weight RBC-UM31PGP(W)-E	kg	4.2
Pipe Connection	Flare Connections (gas - liquid)	inch	5/8 - 3/8
	Drain Pipe Connection OD/ID	mm	VP32/25
Remote Controller			RBC-AMT32E
Power Cable	Outdoor to Indoor		3 core + earth

Dimensional Drawings

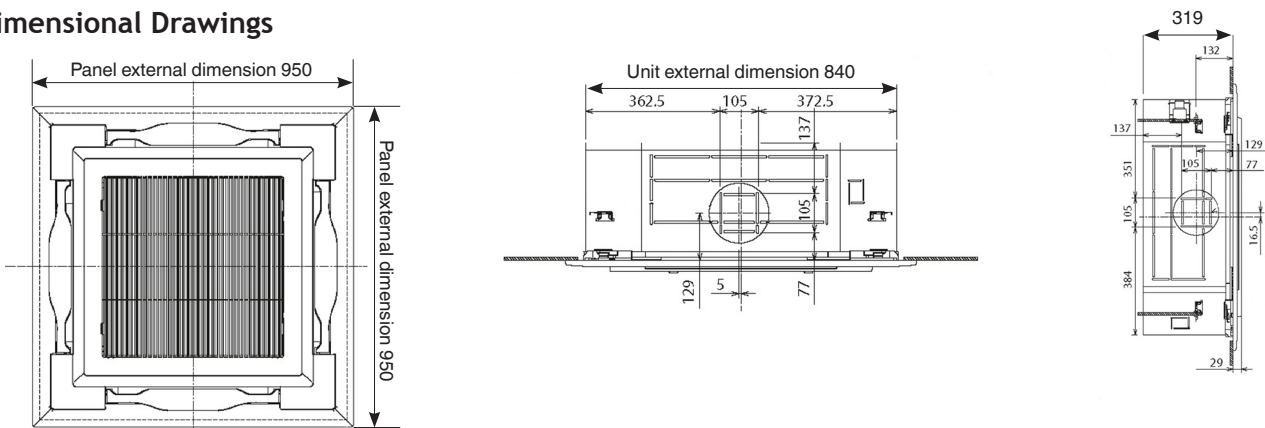

Cool Designs Ltd

Raising the Standards in Air Conditioning Distribution

www.cdlweb.info

