



AIR CONDITIONING



REFRIGERATION



HEATING



alarm

CONDENSATE REMOVAL PUMP

The next step up, our Alarm boiler pump uses centrifugal technology and comes with a built in audible alarm for extra piece of mind.



300L/h max. flow



3.2m max. rec. head (flow rate 50L/h)

KEY FEATURES

- Audible alarm
- Plug & play
- Non return valve
- Wall or floor mounted

SUITABILITY

- Up to 100kW / 341,000Btu/h with condensate PH value >2.7
- Domestic gas & oil fired condensing boilers; High efficiency gas furnace

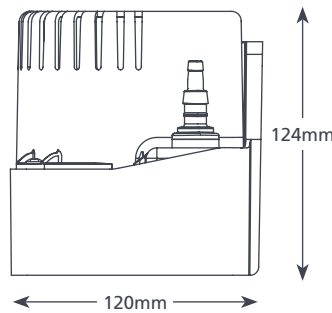
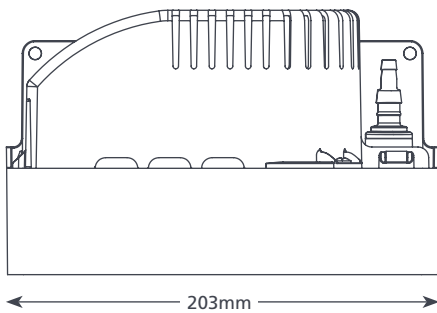

ALARM BOILER SPECIFICATIONS

Max. flow	300L/h @ 0 head
Max. rec. head	3.2m
Tank capacity	0.5L
Sound level@1m	60dB(A)
Power supply	230 VAC, 0.45A, 0.95W, 50Hz
Rated Class	Non continuous I appliance
Max. unit output	100kW / 341,000Btu/h
Max. water temp	60°C / 140°F
Inlet/outlet	27mm in, 6 & 10mm out
IP Protection	IP20
Safety switch	3.0A Normally closed
Thermal protection	✓
Fully potted	n/a
Self priming	n/a

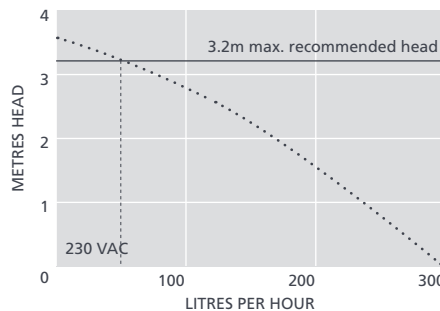

SUGGESTED XTRA ACCESSORIES

Description	Part No.
Tube To Soil Stack Adaptor	FP2038
1 Amp Fuse	FP2620
Vinyl Tube Braided 3/8" (10mm)	AX5101
Acid Neutraliser	FP1021

Xtra For more installation accessories take a look at our Aspen Xtra range

ALARM BOILER OPTIONS

Alarm boiler pump (UK)	FP2950
Alarm boiler pump (EU)	FP2949

IN THE BOX

- Alarm boiler pump
- 2m Plug & play power cable
- 6m discharge tube (6mm ID)
- Pipe adaptor
- Fixing kit
- Install manual

Download manual at aspenspumps.com

Information correct at time of going to press.



aspenspumps.com

+44 (0)1323 848842

sales@aspenspumps.com

reliable | silent | simple