



CIAT - SALSA Cassette air conditioner

SALSA 18HV Cassette air conditioner

Features

- Infra-red controller as standard (wired available).
- Louvre position memory.
- Drain pump up to 750 mm.
- Full Wi-Fi compatibility.
- 360° air distribution.
- Fresh air intake and fan compatible.



Technical Data

| Model reference | | SALSA - Cassette 18HV | |
|------------------------|-------------------------|-----------------------|------------------|
| Indoor unit | | 42KH18VSC | |
| Indoor unit panel | | 40CAS-C6 | |
| Outdoor unit | | 38HU18VSC | |
| Cooling capacity | Min./nom./max. | kW | 2.00/5.00/5.50 |
| Heating capacity* | Min./nom./max. | kW | 2.00/5.50/6.00 |
| | @ -7 °C | kW | 3.90 |
| | @ -10 °C | kW | 3.90 |
| | @ -15 °C | kW | 2.20 |
| SEER | | W/W | 6.0 |
| SCOP | Warmer/average | W/W | 4.0/5.1 |
| Energy label | SEER | | A+ |
| | SCOP warmer/average | | A+/A+++ |
| Rated current | | A | 11 |
| Rated input | | kW | 2.53 |
| Power supply | | V/ph/Hz | 220-240/1/50 |
| Power to | | | Outdoor |
| Interconnecting | | | 5 |
| Refrigerant amount | R410A | kg | 1.70 |
| Liquid side - gas side | | inch | 1/4 - 1/2 |
| Standard piping length | Min./max. piping length | m | 3/30 |
| | Max. height difference | m | 20 |
| | Additional charge | g/m | 15 |
| Indoor unit | | | 42HK18VSC |
| Sound power level** | | dB(A) | 60 |
| Sound pressure level** | High/med./low | dB(A) | 45/42/36 |
| Air flow | High/med./low | m ³ /h | 650/530/370 |
| Weight | Body | kg | 16.5/19.0 |
| | Panel | kg | 2.5/4.5 |
| Dimension | Body W x D x H | mm | 570 x 570 x 260 |
| | Panel W x D x H | mm | 647 x 647 x 50 |

* -7 °C/-10 °C/-15 °C heating at free frequency

** Sound data in cooling mode

Dimensional Drawings

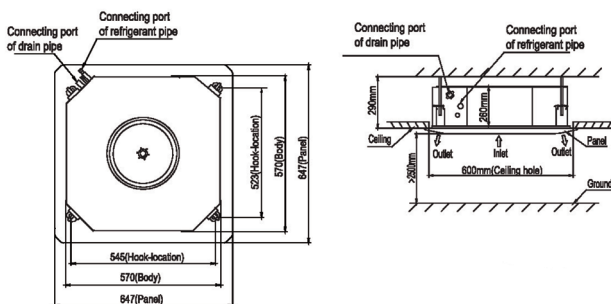

Cool Designs Ltd

Raising the Standards in Air Conditioning Distribution

www.cdlweb.info





CIAT - SALSA Cassette air conditioner

SALSA 18HV
Cassette air conditioner



| | | | |
|------------------------|-----------|-------------------|------------------|
| Outdoor unit | | | 38HU18VSC |
| Sound power level** | | dB(A) | 65 |
| Sound pressure level** | | dB(A) | 57 |
| Air flow | | m ³ /h | 2100 |
| Weight | | kg | 38.0/40.5 |
| Dimension | W x D x H | mm | 800 x 333 x 554 |

** Sound data in cooling mode

Dimensional Drawings

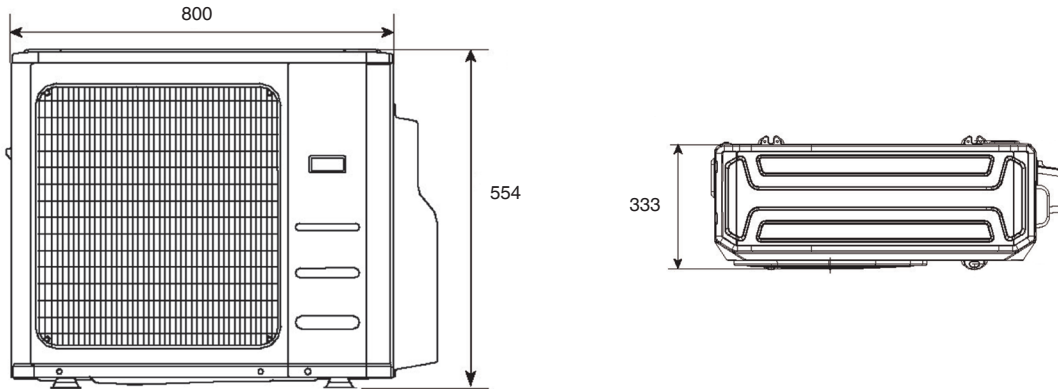

Accessories

| Description | Part Number |
|---|-------------|
| Wired remote control for LC range - KJR-12- G2 | 7511630 |
| Centralised wired remote control for LC range connectable up to 64 units - CCM-30 | 7511631 |

Split-system unit ratings are based on the following conditions:

Cooling capacities: Indoor air temperature 27°C (DB)/19°C (WB) - Outdoor air temperature 35°C (DB)/24°C (WB)

Heating capacities: Indoor air temperature 20°C (DB)/15°C (WB) - Outdoor air temperature 7°C (DB)/6°C (WB)

Cool Designs Ltd

Raising the Standards in Air Conditioning Distribution

www.cdlweb.info

