

TOSHIBA

FILE NO. SVM-10044

SERVICE MANUAL

AIR-CONDITIONER

SPLIT TYPE

Indoor Unit

<Console, Heat Pump Type>

RAS-B10UFV-E

RAS-B13UFV-E

RAS-B18UFV-E

Outdoor Unit

<Heat Pump Type>

RAS-10SAV2-E

RAS-13SAV2-E

RAS-18SAV-E

RAS-18SAV2-E

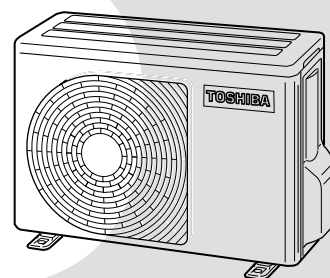
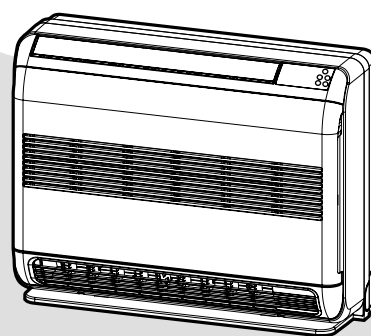

April, 2010

CONTENTS



1. SAFETY PRECAUTIONS	3
2. SPECIFICATIONS	6
3. REFRIGERANT R410A	9
4. CONSTRUCTION VIEWS	17
5. WIRING DIAGRAM	20
6. SPECIFICATIONS OF ELECTRICAL PARTS	22
7. REFRIGERANT CYCLE DIAGRAM	24
8. CONTROL BLOCK DIAGRAM	27
9. OPERATION DESCRIPTION	29
10. INSTALLATION PROCEDURE	62
11. HOW TO DIAGNOSE THE TROUBLE	76
12. HOW TO REPLACE THE MAIN PARTS	98
13. EXPLODED VIEWS AND PARTS LIST	122

1. SAFETY PRECAUTIONS

SAFETY PRECAUTIONS



The important contents concerned to the safety are described on the product itself and on this Service Manual. Please read this Service Manual after understanding the described items thoroughly in the following contents (Indications/Illustrated marks), and keep them.

[Explanation of indications]

Indication	Explanation
 DANGER	Indicates contents assumed that an imminent danger causing a death or serious injury of the repair engineers and the third parties when an incorrect work has been executed.
 WARNING	Indicates possibilities assumed that a danger causing a death or serious injury of the repair engineers, the third parties, and the users due to troubles of the product after work when an incorrect work has been executed.
 CAUTION	Indicates contents assumed that an injury or property damage (*) may be caused on the repair engineers, the third parties, and the users due to troubles of the product after work when an incorrect work has been executed.

* Property damage : Enlarged damage concerned to property, furniture, and domestic animal/pet

[Explanation of illustrated marks]

Mark	Explanation
	Indicates prohibited items (Forbidden items to do) The sentences near an illustrated mark describe the concrete prohibited contents.
	Indicates mandatory items (Compulsory items to do) The sentences near an illustrated mark describe the concrete mandatory contents.
	Indicates cautions (including danger/warning) The sentences or illustration near or in an illustrated mark describe the concrete cautious contents.

For general public use

Power supply cord of outdoor unit shall be 1.5 mm² (H07RN-F or 60245IEC66) polychloroprene sheathed flexible cord.

- Read this “SAFETY PRECAUTIONS” carefully before servicing.
- The precautions described below include the important items regarding safety. Observe them without fail.
- After the servicing work, perform a trial operation to check for any problem.
- Turn off the main power supply switch (or breaker) before the unit maintenance.

CAUTION

New Refrigerant Air Conditioner Installation

- THIS AIR CONDITIONER ADOPTS THE NEW HFC REFRIGERANT (R410A) WHICH DOES NOT DESTROY OZONE LAYER.

R410A refrigerant is apt to be affected by impurities such as water, oxidizing membrane, and oils because the working pressure of R410A refrigerant is approx. 1.6 times of refrigerant R22. Accompanied with the adoption of the new refrigerant, the refrigeration machine oil has also been changed. Therefore, during installation work, be sure that water, dust, former refrigerant, or refrigeration machine oil does not enter into the new type refrigerant R410A air conditioner circuit.

To prevent mixing of refrigerant or refrigerating machine oil, the sizes of connecting sections of charging port on main unit and installation tools are different from those used for the conventional refrigerant units.

Accordingly, special tools are required for the new refrigerant (R410A) units. For connecting pipes, use new and clean piping materials with high pressure fittings made for R410A only, so that water and/or dust does not enter. Moreover, do not use the existing piping because there are some problems with pressure fittings and possible impurities in existing piping.



CAUTION

TO DISCONNECT THE APPLIANCE FROM THE MAIN POWER SUPPLY

A switch or circuit breaker that can disconnect all poles must be included in the fixed wiring.
Be sure to use an approved circuit breaker or switch.



DANGER

- ASK AN AUTHORIZED DEALER OR QUALIFIED INSTALLATION PROFESSIONAL TO INSTALL/ MAINTAIN THE AIR CONDITIONER.
INAPPROPRIATE SERVICING MAY RESULT IN WATER LEAKAGE, ELECTRIC SHOCK OR FIRE.
- TURN OFF MAIN POWER SUPPLY BEFORE ATTEMPTING ANY ELECTRICAL WORK. MAKE SURE ALL POWER SWITCHES ARE OFF. FAILURE TO DO SO MAY CAUSE ELECTRIC SHOCK.



HIGH VOLTAGE

The high voltage circuit is incorporated.

Be careful to do the check service, as the electric shock may be caused in case of touching parts on the P.C. board by hand.

- CORRECTLY CONNECT THE CONNECTING CABLE. IF THE CONNECTING CABLE IS INCORRECTLY CONNECTED, ELECTRIC PARTS MAY BE DAMAGED.
- CHECK THAT THE EARTH WIRE IS NOT BROKEN OR DISCONNECTED BEFORE SERVICE AND INSTALLATION. FAILURE TO DO SO MAY CAUSE ELECTRIC SHOCK.
- DO NOT INSTALL NEAR CONCENTRATIONS OF COMBUSTIBLE GAS OR GAS VAPORS. FAILURE TO FOLLOW THIS INSTRUCTION CAN RESULT IN FIRE OR EXPLOSION.
- TO PREVENT THE INDOOR UNIT FROM OVERHEATING AND CAUSING A FIRE HAZARD, PLACE THE UNIT WELL AWAY (MORE THAN 2 M) FROM HEAT SOURCES SUCH AS RADIATORS, HEAT REGISTORS, FURNACE, STOVES, ETC.
- WHEN MOVING THE AIR-CONDITIONER FOR INSTALLATION IN ANOTHER PLACE, BE VERY CAREFUL NOT TO ALLOW THE SPECIFIED REFRIGERANT (R410A) TO BECOME MIXED WITH ANY OTHER GASEOUS BODY INTO THE REFRIGERATION CIRCUIT. IF AIR OR ANY OTHER GAS IS MIXED IN THE REFRIGERANT, THE GAS PRESSURE IN THE REFRIGERATION CIRCUIT WILL BECOME ABNORMALLY HIGH AND IT MAY RESULT IN THE PIPE BURSTING AND POSSIBLE PERSONNEL INJURIES.
- IN THE EVENT THAT THE REFRIGERANT GAS LEAKS OUT OF THE PIPE DURING THE SERVICE WORK AND THE INSTALLATION WORK, IMMEDIATELY LET FRESH AIR INTO THE ROOM. IF THE REFRIGERANT GAS IS HEATED, SUCH AS BY FIRE, GENERATION OF POISONOUS GAS MAY RESULT.



WARNING

- **Never modify this unit by removing any of the safety guards or bypass any of the safety interlock switches.**
- **Do not install in a place which cannot bear the weight of the unit. Personal injury and property damage can result if the unit falls.**
- **After the installation work, confirm that refrigerant gas does not leak.**
If refrigerant gas leaks into the room and flows near a fire source, such as a cooking range, noxious gas may generate.
- **The electrical work must be performed by a qualified electrician in accordance with the Installation Manual. Make sure the air conditioner uses an exclusive circuit.**
An insufficient circuit capacity or inappropriate installation may cause fire.
- **When wiring, use the specified cables and connect the terminals securely to prevent external forces applied to the cable from affecting the terminals.**
- **Be sure to provide grounding.**
Do not connect ground wires to gas pipes, water pipes, lightning rods or ground wires for telephone cables.
- **Conform to the regulations of the local electric company when wiring the power supply.**
Inappropriate grounding may cause electric shock.



CAUTION

- Exposure of unit to water or other moisture before installation may result in an electrical short. Do not store in a wet basement or expose to rain or water.
- Do not install in a place that can increase the vibration of the unit. Do not install in a place that can amplify the noise level of the unit or where noise or discharged air might disturb neighbors.
- To avoid personal injury, be careful when handling parts with sharp edges.
- Perform the specified installation work to guard against an earthquake.
If the air conditioner is not installed appropriately, accidents may occur due to the falling unit.

For Reference:

If a heating operation would be continuously performed for a long time under the condition that the outdoor temperature is 0°C or lower, drainage of defrosted water may be difficult due to freezing of the bottom plate, resulting in a trouble of the cabinet or fan.

It is recommended to procure an antifreeze heater locally for a safe installation of the air conditioner.

For details, contact the dealer.

2. SPECIFICATIONS

2-1. Specifications

Unit model	Indoor		RAS-B10UFV-E	RAS-B13UFV-E	RAS-B18UFV-E	RAS-B18UFV-E				
	Outdoor		RAS-10SAV2-E	RAS-13SAV2-E	RAS-18SAV-E	RAS-18SAV2-E				
Cooling capacity	(kW)		2.5	3.5	5.0	5.0				
Cooling capacity range	(kW)		1.1-3.1	1.1-4.1	1.0-5.7	1.0-5.7				
Heating capacity	(kW)		3.2	4.2	5.8	5.8				
Heating capacity range	(kW)		0.9-4.8	1.0-5.4	1.1-6.3	1.1-6.3				
Power supply			1Ph/50Hz/220-240V 1Ph/60Hz/220-230V	1Ph/50Hz/220-240V 1Ph/60Hz/220-230V	1Ph/50Hz/220-240V 1Ph/60Hz/220-230V	1Ph/50Hz/220-240V 1Ph/60Hz/220-230V				
Electric characteristic	Indoor	Operation mode	Cooling	Heating	Cooling	Heating	Cooling	Heating		
		Running current (A)	0.17-0.15	0.20-0.19	0.20-0.19	0.24-0.22	0.27-0.24	0.30-0.28	0.27-0.24	0.30-0.28
		Power consumption (W)	20	25	25	30	35	40	35	40
		Power factor (%)	54	56	56	57	60	60	60	60
	Outdoor	Operation mode	Cooling	Heating	Cooling	Heating	Cooling	Heating	Cooling	Heating
		Running current (A)	2.90-2.66	3.51-3.21	4.52-4.14	5.18-4.75	7.54-6.91	8.19-7.50	7.54-6.91	8.19-7.50
		Power consumption (W)	575	725	945	1095	1625	1765	1625	1765
		Power factor (%)	90	94	95	96	98	98	98	98
	Starting current (A)		3.71-3.40		5.42-4.97		8.49-7.78		8.49-7.78	
	COP (Cooling / Heating)			4.20/4.27		3.61-3.73		3.01/3.21		3.01/3.21
Operating noise	Indoor	High (Cooling / Heating) (dB-A)	39/39		40/40		46/46		46/46	
		Medium (Cooling / Heating) (dB-A)	32/32		33/33		40/40		40/40	
		Low (Cooling / Heating) (dB-A)	26/26		27/27		34/34		34/34	
	Outdoor (Cooling / Heating) (dB-A)	46/47		48/50		49/50		49/50		
Indoor unit	Unit model		RAS-B10UFV-E	RAS-B13UFV-E	RAS-B18UFV-E	RAS-B18UFV-E				
	Dimension	Height (mm)	600		600		600			
		Width (mm)	700		700		700			
		Depth (mm)	220		220		220			
	Net weight (kg)		16		16		16			
	Fan motor output (W)		41		41		41			
	Air flow rate (Cooling / Heating) (m ³ / min)		7.8/8.5		8.5/9.2		10.0/10.7			
Outdoor unit	Unit model		RAS-10SAV2-E	RAS-13SAV2-E	RAS-18SAV-E	RAS-18SAV2-E				
	Dimension	Height (mm)	550		550		550			
		Width (mm)	780		780		780			
		Depth (mm)	290		290		290			
	Net weight (kg)		33		39		41			
	Compressor	Motor output (W)	750		750		1100			
		Type	Single rotary type with DC-inverter variable speed control		Single rotary type with DC-inverter variable speed control		Twin rotary type with DC-inverter variable speed control			
		Model	DA89X1C-23FZ2		DA89X1C-23FZ2		DA130A1F-27F			
	Fan motor output (W)		43		43		43			
	Air flow rate (Cooling / Heating) (m ³ / min)		30/30		37.5/37.5		31.9/31.9			
Piping connection	Type		Flare connection		Flare connection		Flare connection			
	Indoor unit	Liquid side (mm)	Ø6.35		Ø6.35		Ø6.35			
		Gas side (mm)	Ø9.52		Ø9.52		Ø12.7			
	Outdoor unit	Liquid side (mm)	Ø6.35		Ø6.35		Ø6.35			
		Gas side (mm)	Ø9.52		Ø9.52		Ø12.7			
	Maximum length (m)		20		20		20			
	Maximum charge-less length (m)		15		15		15			
	Maximum height difference (m)		10		10		10			
Refrigerant	Name of refrigerant		R410A		R410A		R410A			
	Weight (kg)		0.8		0.8		1.4			
Wiring connection	Power supply		3 Wires:Includes earth		3 Wires:Includes earth		3 Wires:Includes earth			
	Interconnection		4 Wires:Includes earth		4 Wires:Includes earth		4 Wires:Includes earth			
Usable temperature range	Indoor (Cooling / Heating) (°C)		21-32/0-28		21-32/0-28		21-32/0-28			
	Outdoor (Cooling / Heating) (°C)		-10-46/-15-24		-10-46/-15-24		-10-46/-15-24			
Accessory	Indoor unit	Installation plate	1		1		1			
		Wireless remote controller	1		1		1			
		Batteries	2		2		2			
		Toshiba New IAO Filter	2		2		2			
		Install screw	8		8		8			
		Remote controller holder	1		1		1			
		Pan head wood screw for Remote control holder	2		2		2			
		Insulate pipe	1		1		1			
		Installation manual	1		1		1			
	Owner's manual	1		1		1				
	Outdoor unit	Drain nipple	1		1		1			
Water-proof rubber cap		2		2		2				

* The specification may be subject to change without notice for purpose of improvement.

2-2. Combined multi-split outdoor unit

The multi-split outdoor units, which can be combined with B**UFV-E series indoor unit are as described below:

Outdoor unit type	Combined outdoor unit model name	Indoor unit model name		
		B18UFV-E	B13UFV-E	B10UFV-E
2-room Multi outdoor unit	RAS-M14GAV-E	X	○	○
	RAS-M18GAV-E	X	○	○
3-room Multi outdoor unit	RAS-3M18SAV-E	X	○	○
	RAS-3M26GAV-E1	○	○	○
4-room Multi outdoor unit	RAS-4M23SAV-E	○	○	○
	RAS-4M27GAV-E1	○	○	○
5-room Multi outdoor unit	RAS-5M34UAV-E	○	○	○

○ : Combination available

X : Combination unavailable

This service manual describes about B**UFV-E series indoor units only.

For the multi-split outdoor unit to be combined, refer to the service manual.

Outdoor unit	File name
Heat Pump Model	
RAS-M14GAV-E	A05-009-1
RAS-M18GAV-E	
RAS-3M18SAV-E	A06-013
RAS-4M23SAV-E	A06-014
RAS-3M26GAV-E1,RAS-4M27GAV-E1	A08-016
RAS-5M34UAV-E	A09-011

2-2. Operation Characteristic Curve

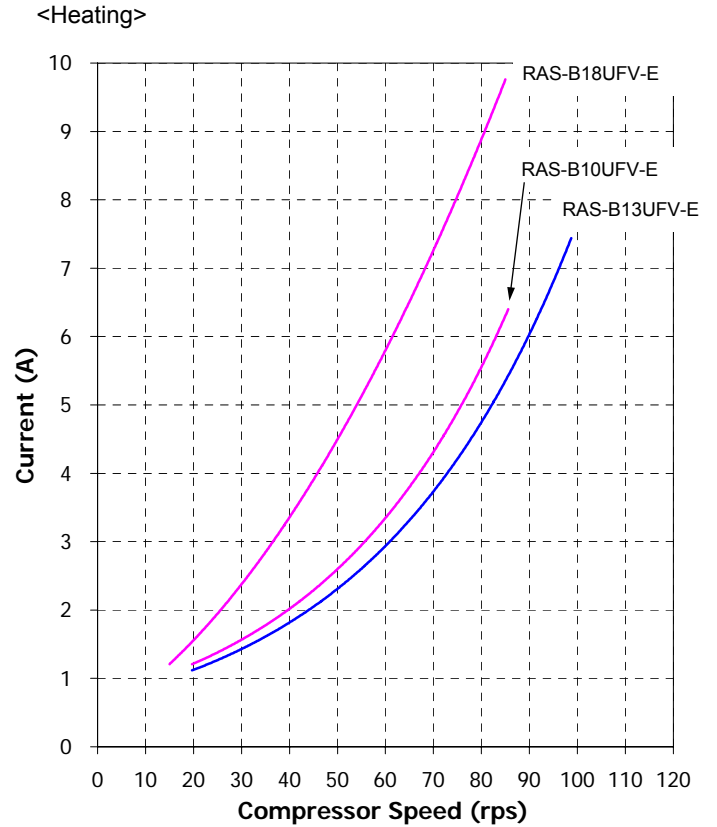
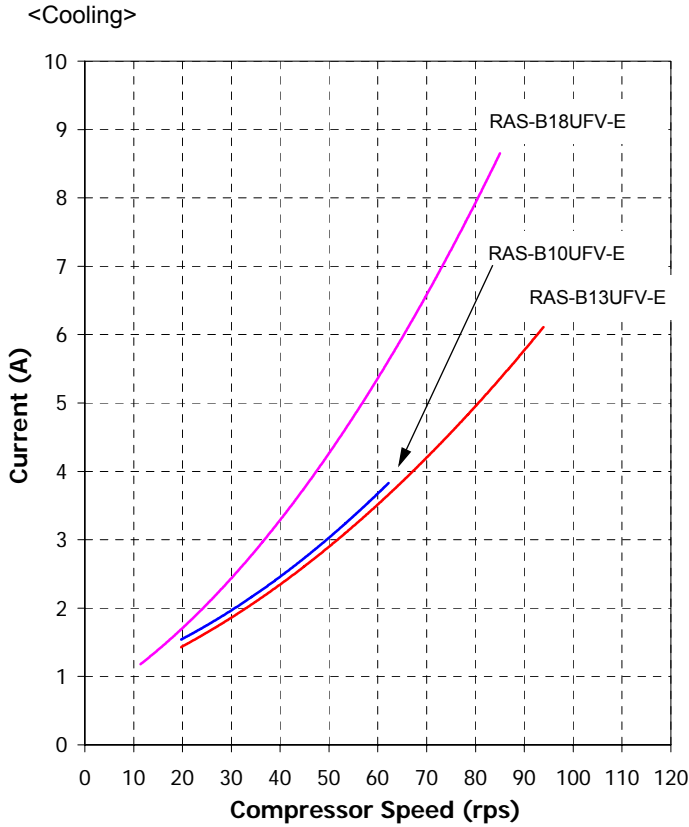

2-3. Capacity Variation Ratio According to Temperature

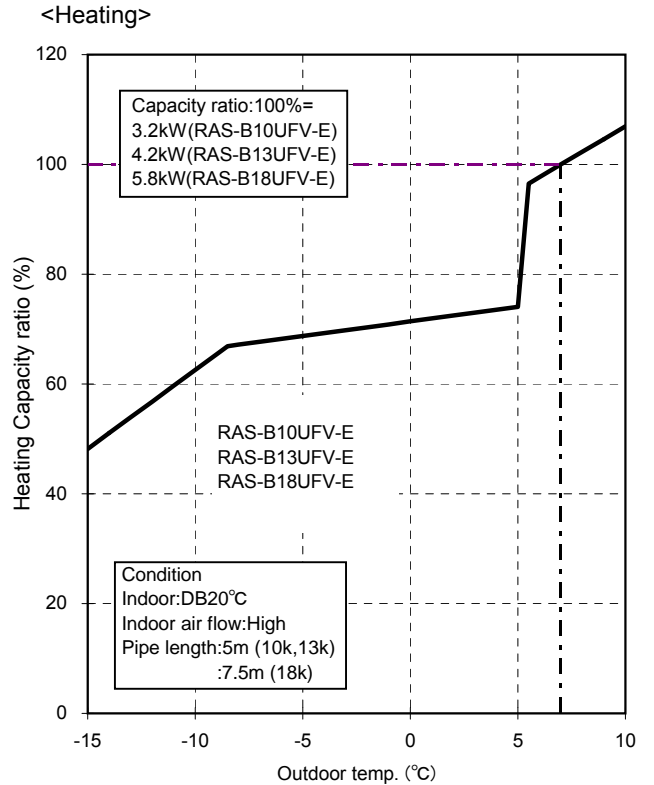
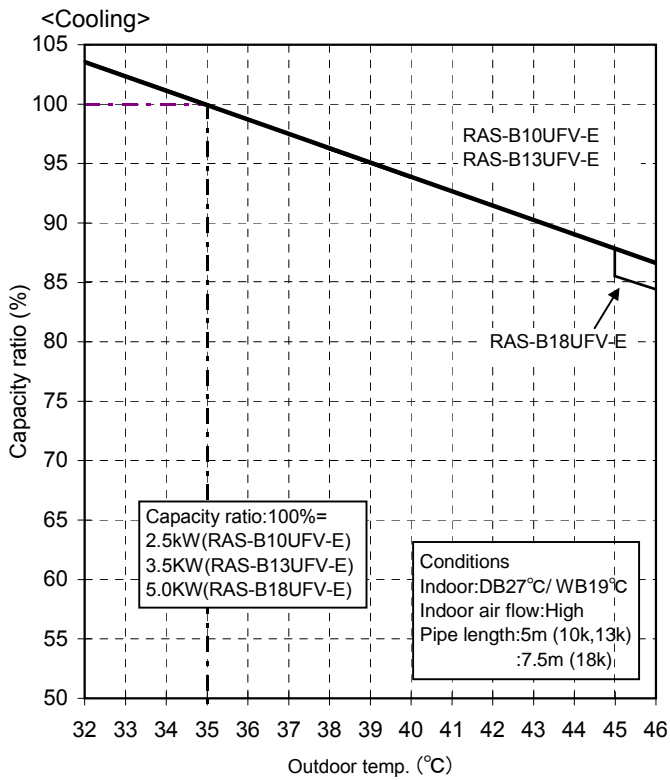

3. REFRIGERANT R410A

This air conditioner adopts the new refrigerant HFC (R410A) which does not damage the ozone layer.

The working pressure of the new refrigerant R410A is 1.6 times higher than conventional refrigerant (R22). The refrigerating oil is also changed in accordance with change of refrigerant, so be careful that water, dust, and existing refrigerant or refrigerating oil are not entered in the refrigerant cycle of the air conditioner using the new refrigerant during installation work or servicing time.

The next section describes the precautions for air conditioner using the new refrigerant. Conforming to contents of the next section together with the general cautions included in this manual, perform the correct and safe work.

3-1. Safety During Installation/Serviceing

As R410A's pressure is about 1.6 times higher than that of R22, improper installation/serviceing may cause a serious trouble. By using tools and materials exclusive for R410A, it is necessary to carry out installation/serviceing safely while taking the following precautions into consideration.

1. Never use refrigerant other than R410A in an air conditioner which is designed to operate with R410A.
If other refrigerant than R410A is mixed, pressure in the refrigeration cycle becomes abnormally high, and it may cause personal injury, etc. by a rupture.
2. Confirm the used refrigerant name, and use tools and materials exclusive for the refrigerant R410A.
The refrigerant name R410A is indicated on the visible place of the outdoor unit of the air conditioner using R410A as refrigerant. To prevent mischarging, the diameter of the service port differs from that of R22.
3. If a refrigeration gas leakage occurs during installation/serviceing, be sure to ventilate fully.
If the refrigerant gas comes into contact with fire, a poisonous gas may occur.
4. When installing or removing an air conditioner, do not allow air or moisture to remain in the refrigeration cycle. Otherwise, pressure in the refrigeration cycle may become abnormally high so that a rupture or personal injury may be caused.
5. After completion of installation work, check to make sure that there is no refrigeration gas leakage.
If the refrigerant gas leaks into the room, coming into contact with fire in the fan-driven heater, space heater, etc., a poisonous gas may occur.

6. When an air conditioning system charged with a large volume of refrigerant is installed in a small room, it is necessary to exercise care so that, even when refrigerant leaks, its concentration does not exceed the marginal level.

If the refrigerant gas leakage occurs and its concentration exceeds the marginal level, an oxygen starvation accident may result.

7. Be sure to carry out installation or removal according to the installation manual.
Improper installation may cause refrigeration trouble, water leakage, electric shock, fire, etc.
8. Unauthorized modifications to the air conditioner may be dangerous. If a breakdown occurs please call a qualified air conditioner technician or electrician.
Improper repair's may result in water leakage, electric shock and fire, etc.

3-2. Refrigerant Piping Installation

3-2-1. Piping Materials and Joints Used

For the refrigerant piping installation, copper pipes and joints are mainly used. Copper pipes and joints suitable for the refrigerant must be chosen and installed. Furthermore, it is necessary to use clean copper pipes and joints whose interior surfaces are less affected by contaminants.

1. Copper Pipes

It is necessary to use seamless copper pipes which are made of either copper or copper alloy and it is desirable that the amount of residual oil is less than 40 mg/10 m. Do not use copper pipes having a collapsed, deformed or discolored portion (especially on the interior surface).

Otherwise, the expansion valve or capillary tube may become blocked with contaminants.

As an air conditioner using R410A incurs pressure higher than when using R22, it is necessary to choose adequate materials.

Thicknesses of copper pipes used with R410A are as shown in Table 3-2-1. Never use copper pipes thinner than 0.8 mm even when it is available on the market.

Table 3-2-1 Thicknesses of annealed copper pipes

		Thickness (mm)	
Nominal diameter	Outer diameter (mm)	R410A	R22
1/4	6.35	0.80	0.80
3/8	9.52	0.80	0.80
1/2	12.70	0.80	0.80
5/8	15.88	1.00	1.00

2. Joints

For copper pipes, flare joints or socket joints are used. Prior to use, be sure to remove all contaminants.

a) Flare Joints

Flare joints used to connect the copper pipes cannot be used for pipings whose outer diameter exceeds 20 mm. In such a case, socket joints can be used.

Sizes of flare pipe ends, flare joint ends and flare nuts are as shown in Tables 3-2-3 to 3-2-6 below.

b) Socket Joints

Socket joints are such that they are brazed for connections, and used mainly for thick pipings whose diameter is larger than 20 mm.

Thicknesses of socket joints are as shown in Table 3-2-2.

Table 3-2-2 Minimum thicknesses of socket joints

Nominal diameter	Reference outer diameter of copper pipe jointed (mm)	Minimum joint thickness (mm)
1/4	6.35	0.50
3/8	9.52	0.60
1/2	12.70	0.70
5/8	15.88	0.80

3-2-2. Processing of Piping Materials

When performing the refrigerant piping installation, care should be taken to ensure that water or dust does not enter the pipe interior, that no other oil than lubricating oils used in the installed air-water heat pump is used, and that refrigerant does not leak. When using lubricating oils in the piping processing, use such lubricating oils whose water content has been removed. When stored, be sure to seal the container with an airtight cap or any other cover.

1. Flare processing procedures and precautions

a) Cutting the Pipe

By means of a pipe cutter, slowly cut the pipe so that it is not deformed.

b) Removing Burrs and Chips

If the flared section has chips or burrs, refrigerant leakage may occur.

Carefully remove all burrs and clean the cut surface before installation.

c) Insertion of Flare Nut

d) Flare Processing

Make certain that a clamp bar and copper pipe have been cleaned.

By means of the clamp bar, perform the flare processing correctly.

Use either a flare tool for R410A or conventional flare tool.

Flare processing dimensions differ according to the type of flare tool. When using a conventional flare tool, be sure to secure "dimension A" by using a gauge for size adjustment.

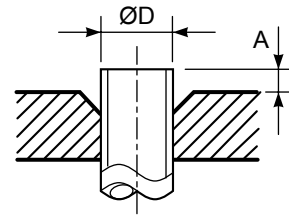

Fig. 3-2-1 Flare processing dimensions

Table 3-2-3 Dimensions related to flare processing for R410A

Nominal diameter	Outer diameter (mm)	Thickness (mm)	A (mm)		
			Flare tool for R410A clutch type	Conventional flare tool	
				Clutch type	Wing nut type
1/4	6.35	0.8	0 to 0.5	1.0 to 1.5	1.5 to 2.0
3/8	9.52	0.8	0 to 0.5	1.0 to 1.5	1.5 to 2.0
1/2	12.70	0.8	0 to 0.5	1.0 to 1.5	2.0 to 2.5
5/8	15.88	1.0	0 to 0.5	1.0 to 1.5	2.0 to 2.5

Table 3-2-4 Dimensions related to flare processing for R22

Nominal diameter	Outer diameter (mm)	Thickness (mm)	A (mm)		
			Flare tool for R22 clutch type	Conventional flare tool	
				Clutch type	Wing nut type
1/4	6.35	0.8	0 to 0.5	0.5 to 1.0	1.0 to 1.5
3/8	9.52	0.8	0 to 0.5	0.5 to 1.0	1.0 to 1.5
1/2	12.70	0.8	0 to 0.5	0.5 to 1.0	1.5 to 2.0
5/8	15.88	1.0	0 to 0.5	0.5 to 1.0	1.5 to 2.0

Table 3-2-5 Flare and flare nut dimensions for R410A

Nominal diameter	Outer diameter (mm)	Thickness (mm)	Dimension (mm)				Flare nut width (mm)
			A	B	C	D	
1/4	6.35	0.8	9.1	9.2	6.5	13	17
3/8	9.52	0.8	13.2	13.5	9.7	20	22
1/2	12.70	0.8	16.6	16.0	12.9	23	26
5/8	15.88	1.0	19.7	19.0	16.0	25	29

Table 3-2-6 Flare and flare nut dimensions for R22

Nominal diameter	Outer diameter (mm)	Thickness (mm)	Dimension (mm)				Flare nut width (mm)
			A	B	C	D	
1/4	6.35	0.8	9.0	9.2	6.5	13	17
3/8	9.52	0.8	13.0	13.5	9.7	20	22
1/2	12.70	0.8	16.2	16.0	12.9	20	24
5/8	15.88	1.0	19.7	19.0	16.0	23	27
3/4	19.05	1.0	23.3	24.0	19.2	34	36

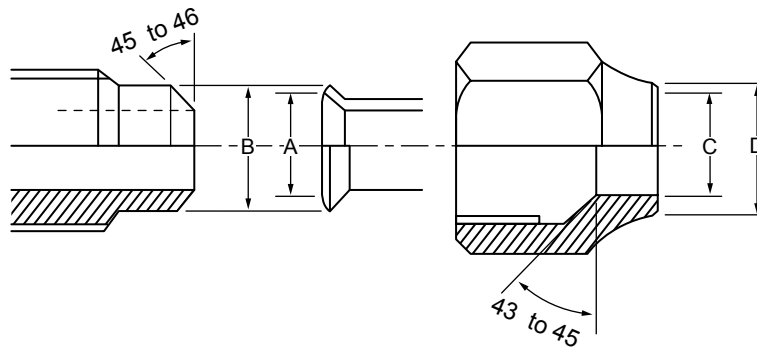

Fig. 3-2-2 Relations between flare nut and flare seal surface

2. Flare Connecting Procedures and Precautions

- a) Make sure that the flare and union portions do not have any scar or dust, etc.
- b) Correctly align the processed flare surface with the union axis.
- c) Tighten the flare with designated torque by means of a torque wrench. The tightening torque for R410A is the same as that for conventional R22. Incidentally, when the torque is weak, the gas leakage may occur. When it is strong, the flare nut may crack and may be made non-removable. When choosing the tightening torque, comply with values designated by manufacturers. Table 3-2-7 shows reference values.

NOTE :

When applying oil to the flare surface, be sure to use oil designated by the manufacturer. If any other oil is used, the lubricating oils may deteriorate and cause the compressor to burn out.

Table 3-2-7 Tightening torque of flare for R410A [Reference values]

Nominal diameter	Outer diameter (mm)	Tightening torque N•m (kgf•cm)	Tightening torque of torque wrenches available on the market N•m (kgf•cm)
1/4	6.35	14 to 18 (140 to 180)	16 (160), 18 (180)
3/8	9.52	33 to 42 (330 to 420)	42 (420)
1/2	12.70	50 to 62 (500 to 620)	55 (550)
5/8	15.88	63 to 77 (630 to 770)	65 (650)

3-3. Tools

3-3-1. Required Tools

The service port diameter of packed valve of the outdoor unit in the air-water heat pump using R410A is changed to prevent mixing of other refrigerant. To reinforce the pressure-resisting strength, flare processing dimensions and opposite side dimension of flare nut (For Ø12.7 copper pipe) of the refrigerant piping are lengthened.

The used refrigerating oil is changed, and mixing of oil may cause a trouble such as generation of sludge, clogging of capillary, etc. Accordingly, the tools to be used are classified into the following three types.

1. Tools exclusive for R410A (Those which cannot be used for conventional refrigerant (R22))
2. Tools exclusive for R410A, but can be also used for conventional refrigerant (R22)
3. Tools commonly used for R410A and for conventional refrigerant (R22)

The table below shows the tools exclusive for R410A and their interchangeability.

Tools exclusive for R410A (The following tools for R410A are required.)

Tools whose specifications are changed for R410A and their interchangeability

No.	Used tool	Usage	R410A air-water heat pump installation		Conventional air-water heat pump installation
			Existence of new equipment for R410A	Whether conven- tional equipment can be used	Whether new equipment can be used with conventional refrigerant
1	Flare tool	Pipe flaring	Yes	*(Note 1)	Yes
2	Copper pipe gauge for adjusting projection margin	Flaring by conventional flare tool	Yes	*(Note 1)	*(Note 1)
3	Torque wrench (For Ø12.7)	Connection of flare nut	Yes	No	No
4	Gauge manifold	Evacuating, refrigerant charge, run check, etc.	Yes	No	No
5	Charge hose				
6	Vacuum pump adapter	Vacuum evacuating	Yes	No	Yes
7	Electronic balance for refrigerant charging	Refrigerant charge	Yes	Yes	Yes
8	Refrigerant cylinder	Refrigerant charge	Yes	No	No
9	Leakage detector	Gas leakage check	Yes	No	Yes
10	Charging cylinder	Refrigerant charge	*(Note 2)	No	No

(Note 1) When flaring is carried out for R410A using the conventional flare tools, adjustment of projection margin is necessary. For this adjustment, a copper pipe gauge, etc. are necessary.

(Note 2) Charging cylinder for R410A is being currently developed.

General tools (Conventional tools can be used.)

In addition to the above exclusive tools, the following equipments which serve also for R22 are necessary as the general tools.

- | | | |
|--|-----------------------------|---|
| 1. Vacuum pump
Use vacuum pump by attaching
vacuum pump adapter. | 4. Reamer | 9. Hole core drill (Ø65) |
| 2. Torque wrench (For Ø6.35, Ø9.52) | 5. Pipe bender | 10. Hexagon wrench
(Opposite side 4mm) |
| 3. Pipe cutter | 6. Level vial | 11. Tape measure |
| | 7. Screwdriver (+, -) | 12. Metal saw |
| | 8. Spanner or Monkey wrench | |

Also prepare the following equipments for other installation method and run check.

- | | |
|----------------|---------------------------------|
| 1. Clamp meter | 3. Insulation resistance tester |
| 2. Thermometer | 4. Electroscop |

3-4. Recharging of Refrigerant

When it is necessary to recharge refrigerant, charge the specified amount of new refrigerant according to the following steps.

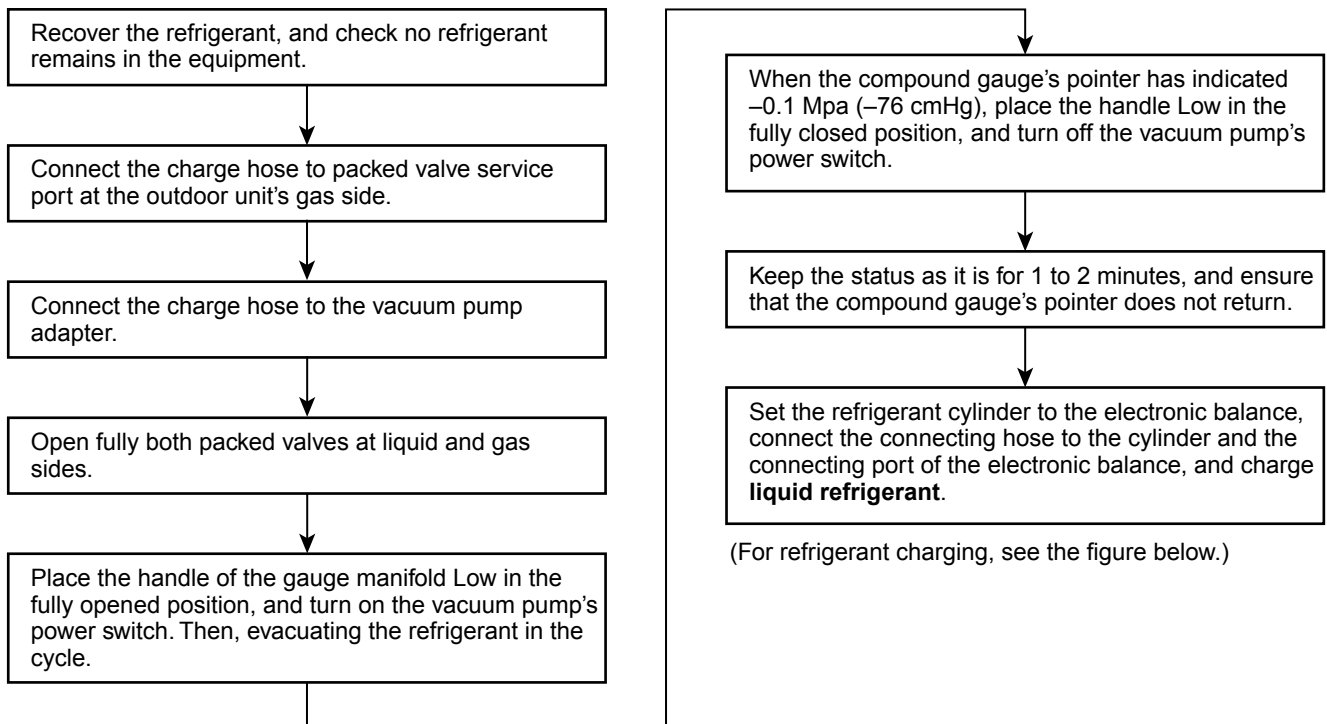

⚠ CAUTION

1. Never charge refrigerant exceeding the specified amount.
2. If the specified amount of refrigerant cannot be charged, charge refrigerant bit by bit in COOL mode.
3. Do not carry out additional charging.

When additional charging is carried out if refrigerant leaks, the refrigerant composition changes in the refrigeration cycle, that is characteristics of the air conditioner changes, refrigerant exceeding the specified amount is charged, and working pressure in the refrigeration cycle becomes abnormally high pressure, and may cause a rupture or personal injury.

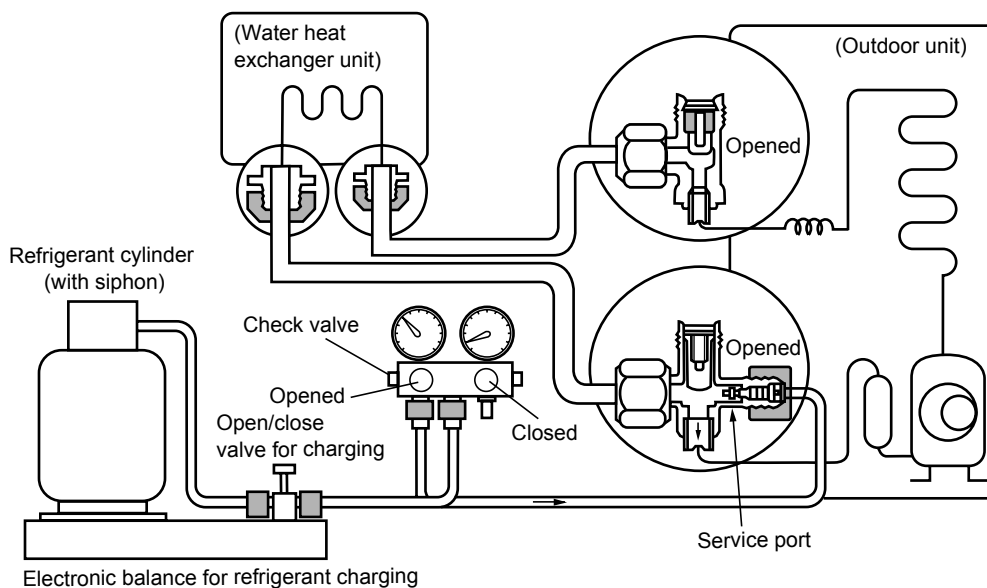
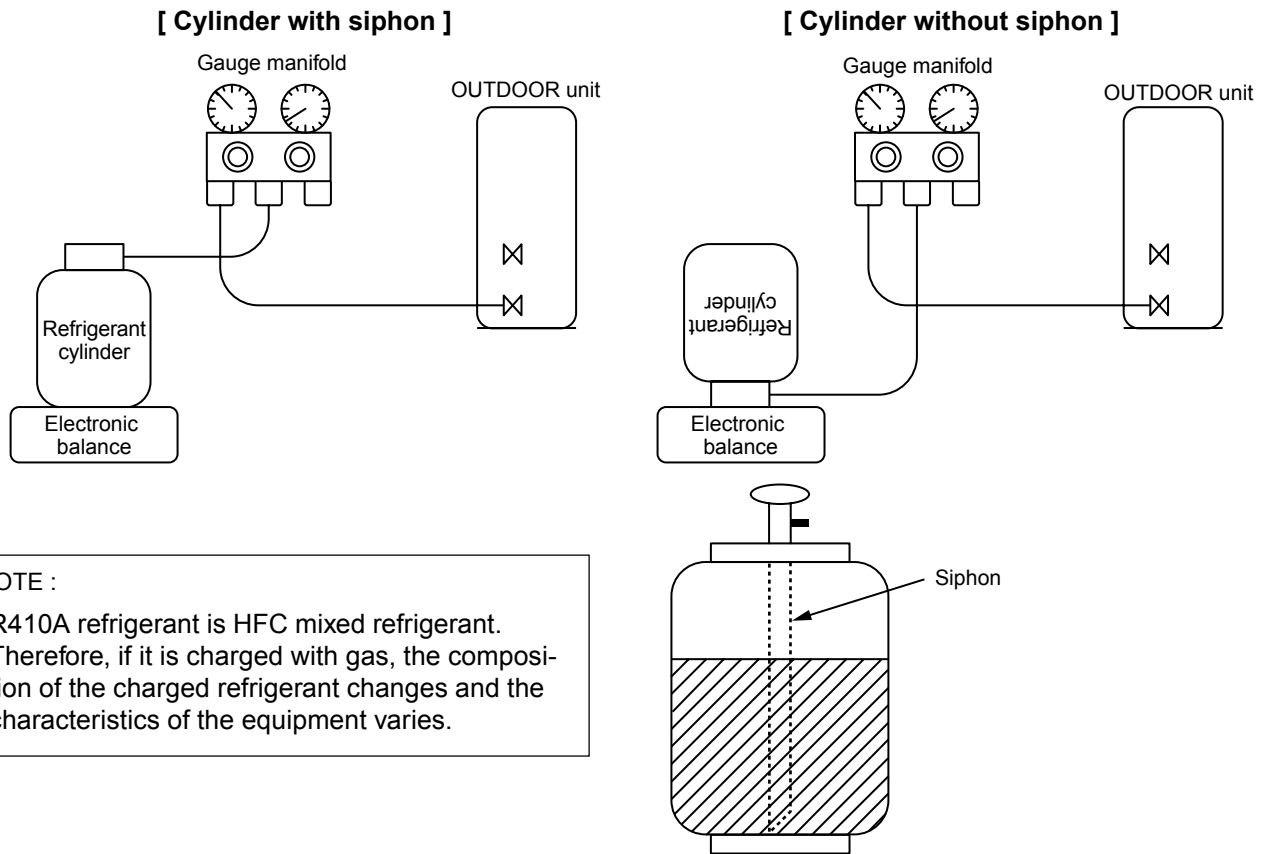

Fig. 3-4-1 Configuration of refrigerant charging

NOTE :

1. Be sure to make setting so that **liquid** can be charged.
2. When using a cylinder equipped with a siphon, liquid can be charged without turning it upside down.

It is necessary for charging refrigerant under condition of liquid because R410A is mixed type of refrigerant. Accordingly, when charging refrigerant from the refrigerant cylinder to the equipment, charge it turning the cylinder upside down if cylinder is not equipped with siphon.



NOTE :

R410A refrigerant is HFC mixed refrigerant. Therefore, if it is charged with gas, the composition of the charged refrigerant changes and the characteristics of the equipment varies.

Fig. 3-4-2

3-5. Brazing of Pipes

3-5-1. Materials for Brazing

1. Silver brazing filler

Silver brazing filler is an alloy mainly composed of silver and copper. It is used to join iron, copper or copper alloy, and is relatively expensive though it excels in solderability.

2. Phosphor bronze brazing filler

Phosphor bronze brazing filler is generally used to join copper or copper alloy.

3. Low temperature brazing filler

Low temperature brazing filler is generally called solder, and is an alloy of tin and lead. Since it is weak in adhesive strength, do not use it for refrigerant pipes.

REQUIREMENT :

1. Phosphor bronze brazing filler tends to react with sulfur and produce a fragile compound water solution, which may cause a gas leakage. Therefore, use any other type of brazing filler at a hot spring resort, etc., and coat the surface with a paint.
2. When performing brazing again at time of servicing, use the same type of brazing filler.

3-5-2. Flux

1. Reason why flux is necessary

- By removing the oxide film and any foreign matter on the metal surface, it assists the flow of brazing filler.
- In the brazing process, it prevents the metal surface from being oxidized.
- By reducing the brazing filler's surface tension, the brazing filler adheres better to the treated metal.

2. Characteristics required for flux

- Activated temperature of flux coincides with the brazing temperature.
- Due to a wide effective temperature range, flux is hard to carbonize.
- It is easy to remove slag after brazing.
- The corrosive action to the treated metal and brazing filler is minimum.
- It excels in coating performance and is harmless to the human body.

As the flux works in a complicated manner as described above, it is necessary to select an adequate type of flux according to the type and shape of treated metal, type of brazing filler and brazing method, etc.

3. Types of flux

• Noncorrosive flux

Generally, it is a compound of borax and boric acid.

It is effective in case where the brazing temperature is higher than 800°C.

• Activated flux

Most of fluxes generally used for silver brazing are this type.

It features an increased oxide film removing capability due to the addition of compounds such as potassium fluoride, potassium chloride and sodium fluoride to the borax-boric acid compound.

4. Piping materials for brazing and used brazing filler/flux

Piping material	Used brazing filler	Used flux
Copper - Copper	Phosphor copper	Do not use
Copper - Iron	Silver	Paste flux
Iron - Iron	Silver	Vapor flux

NOTE :

1. Do not enter flux into the refrigeration cycle.
2. When chlorine contained in the flux remains within the pipe, the lubricating oil deteriorates. Therefore, use a flux which does not contain chlorine.
3. When adding water to the flux, use water which does not contain chlorine (e.g. distilled water or ion-exchange water).
4. Remove the flux after brazing.

3-5-3. Brazing

As brazing work requires sophisticated techniques, experiences based upon a theoretical knowledge, it must be performed by a person qualified.

In order to prevent the oxide film from occurring in the pipe interior during brazing, it is effective to proceed with brazing while letting dry Nitrogen gas (N₂) flow.



CAUTION

Never use gas other than Nitrogen gas.

1. Brazing method to prevent oxidation

- 1) Attach a reducing valve and a flow-meter to the Nitrogen gas cylinder.
- 2) Use a copper pipe to direct the piping material, and attach a flow-meter to the cylinder.
- 3) Apply a seal onto the clearance between the piping material and inserted copper pipe for Nitrogen in order to prevent backflow of the Nitrogen gas.
- 4) When the Nitrogen gas is flowing, be sure to keep the piping end open.
- 5) Adjust the flow rate of Nitrogen gas so that it is lower than 0.05 m³/Hr or 0.02 MPa (0.2kgf/cm²) by means of the reducing valve.
- 6) After performing the steps above, keep the Nitrogen gas flowing until the pipe cools down to a certain extent (temperature at which pipes are touchable with hands).
- 7) Remove the flux completely after brazing.

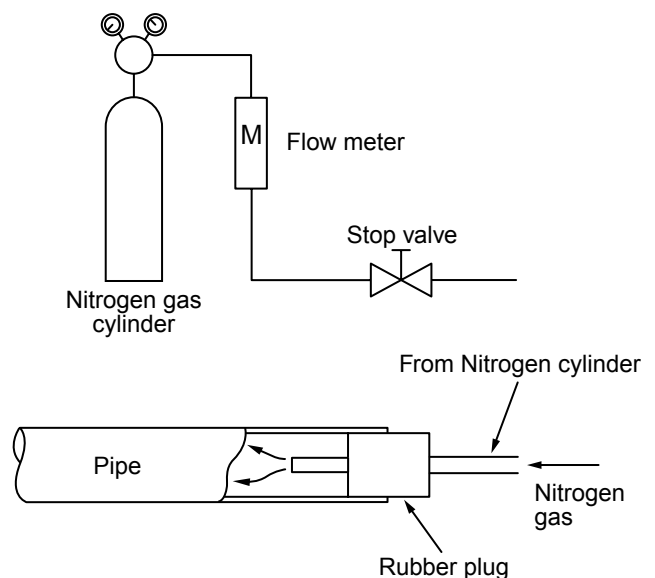
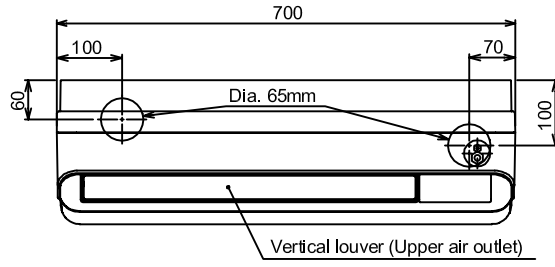

Fig. 3-5-1 Prevention of oxidation during brazing

4. CONSTRUCTION VIEWS

4-1. Indoor Unit

RAS-B10UFV-E
RAS-B13UFV-E
RAS-B18UFV-E



Connecting pipe

	10UFV series 13UFV series	18UFV series
Liquid side	dia. 6.35	dia. 6.35
Gas side	dia. 9.52	dia. 12.7

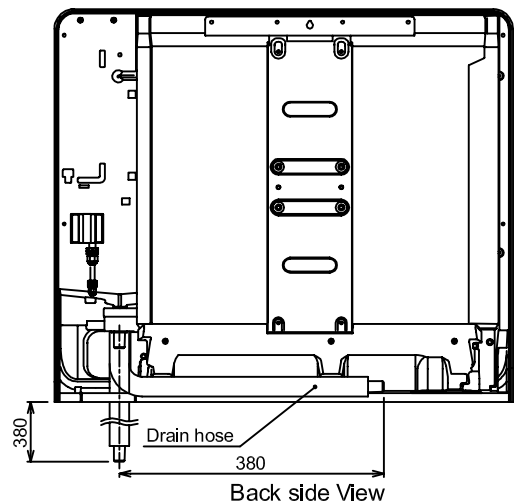
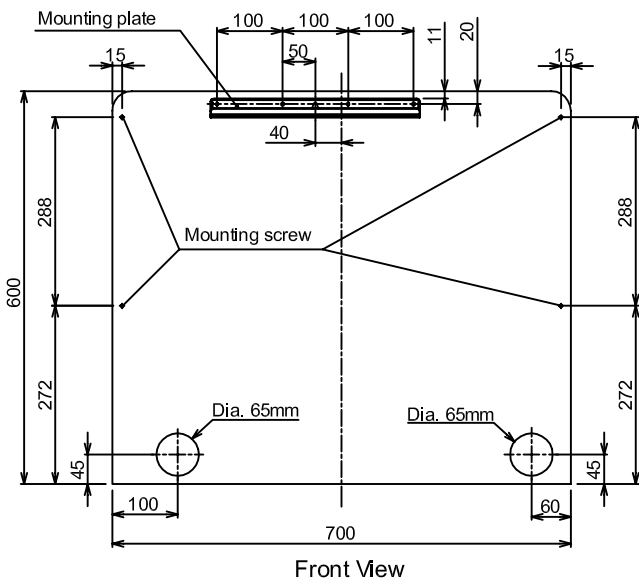
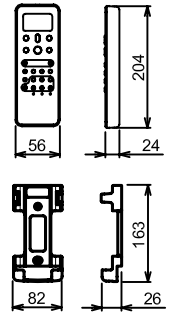
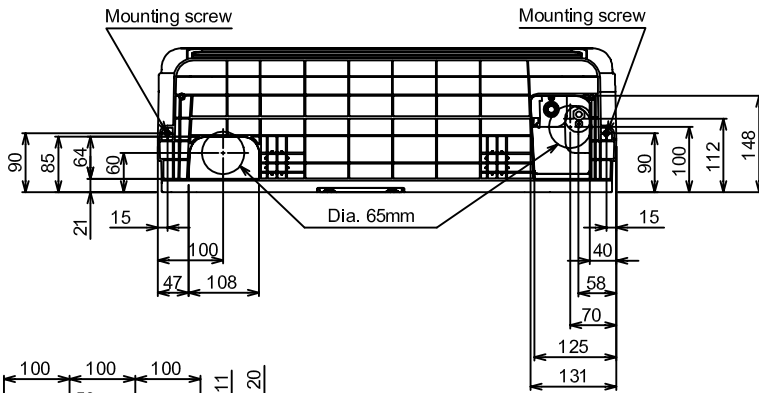
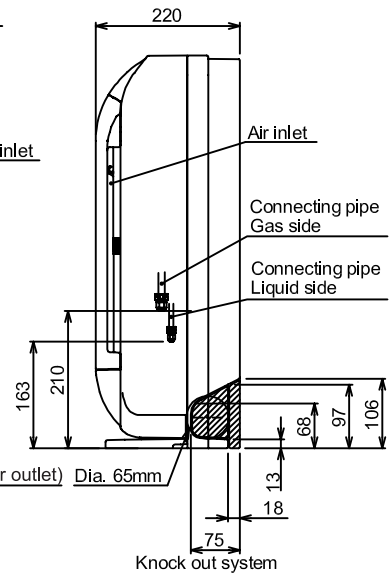
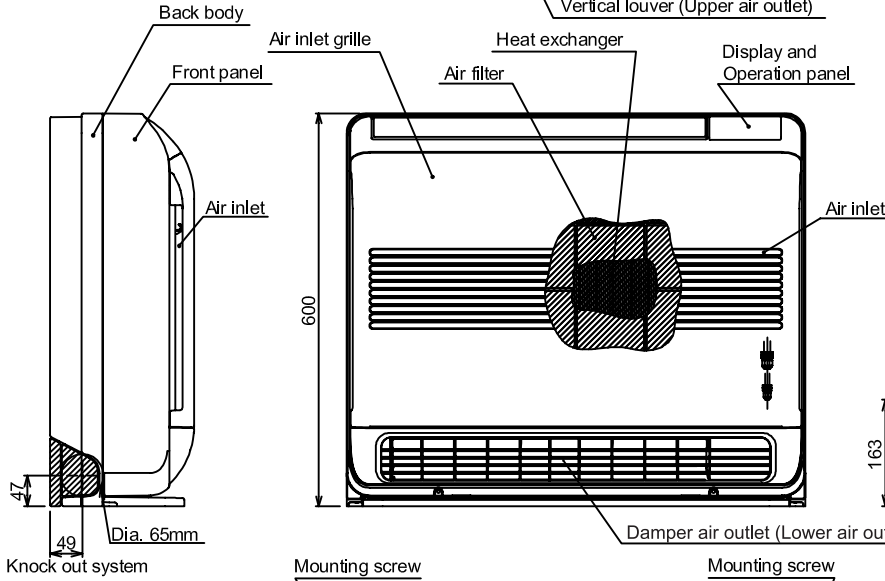

4-2. Outdoor Unit

RAS-10SAV2-E
RAS-13SAV2-E

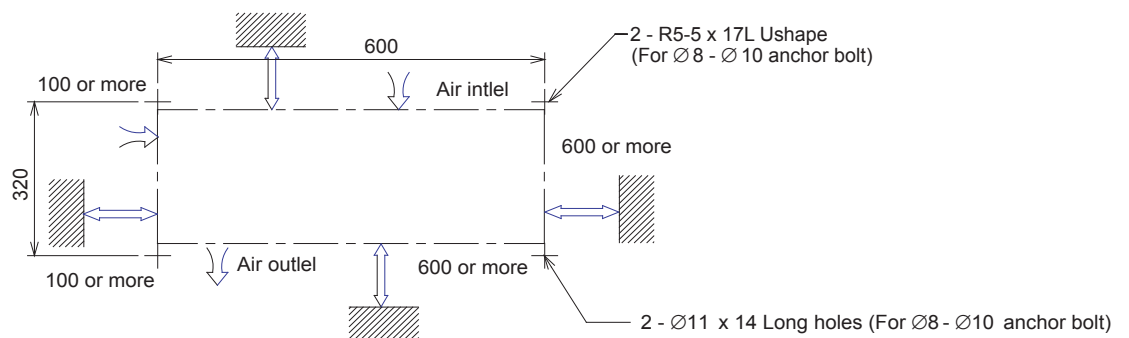
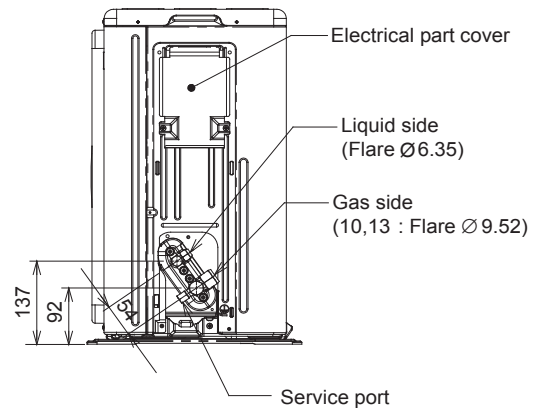
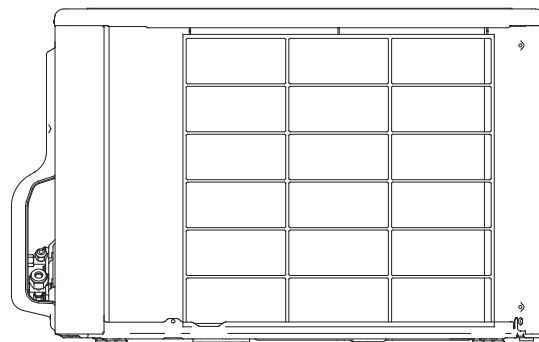
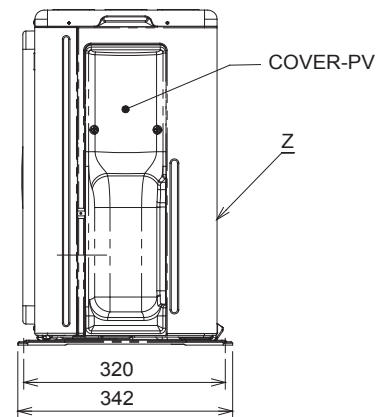
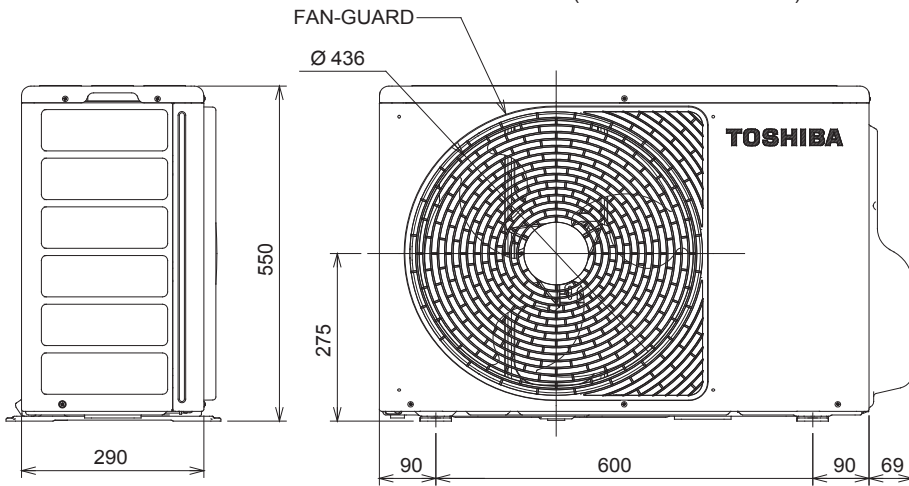
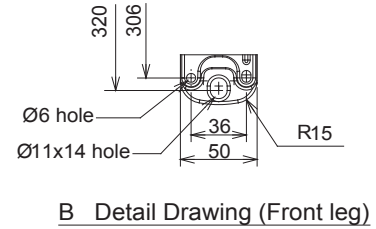
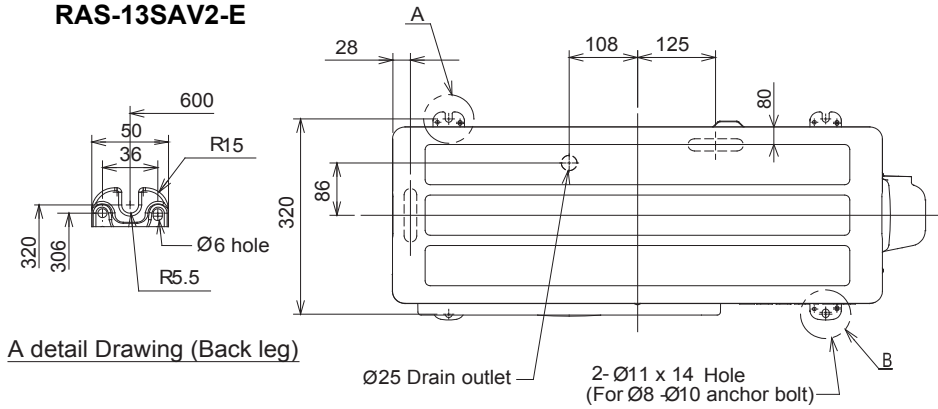

Installation dimension

4-3. Outdoor Unit

RAS-18SAV-E

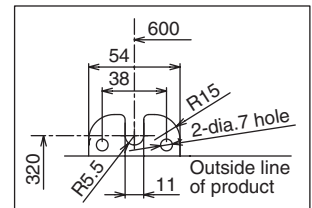
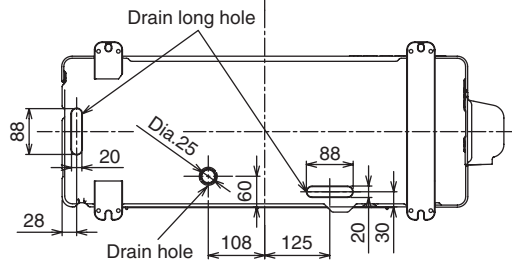
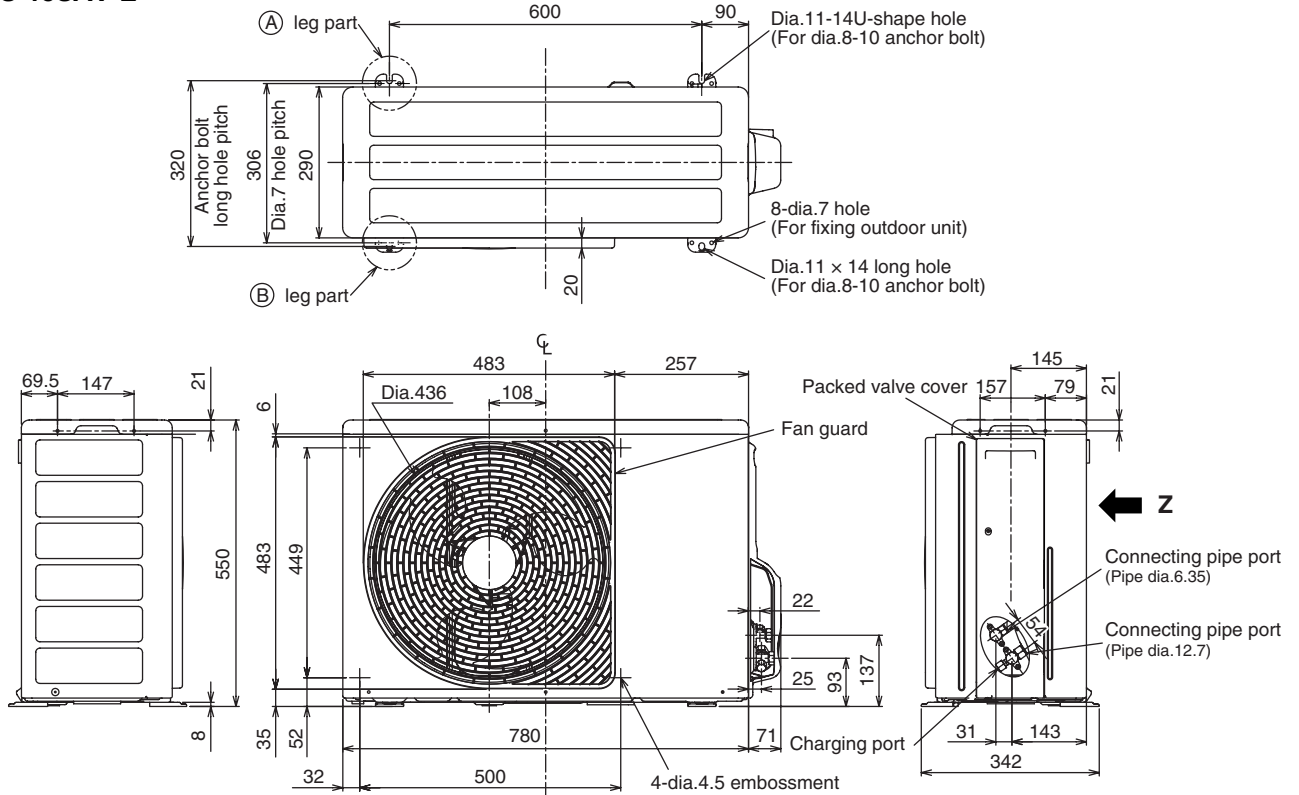

Detailed (A) leg part

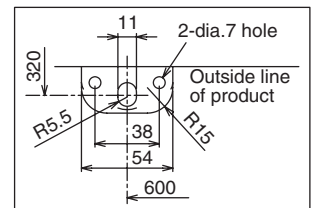
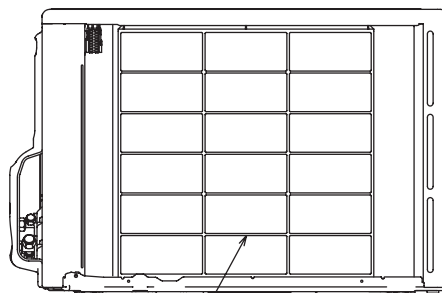

Detailed (B) leg part

Z view

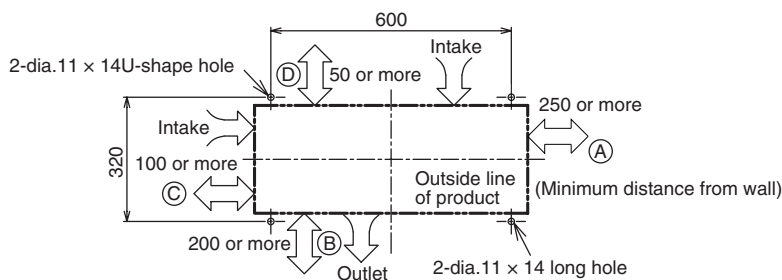

Mounting dimensions of anchor bolt

When installing the outdoor unit, leave open in at least two of directions (A), (B), (C) and (D) shown in the figure.

Unit : mm

5. WIRING DIAGRAM

5-1. RAS-B10UFV-E / RAS-10SAV2-E RAS-B13UFV-E / RAS-13SAV2-E

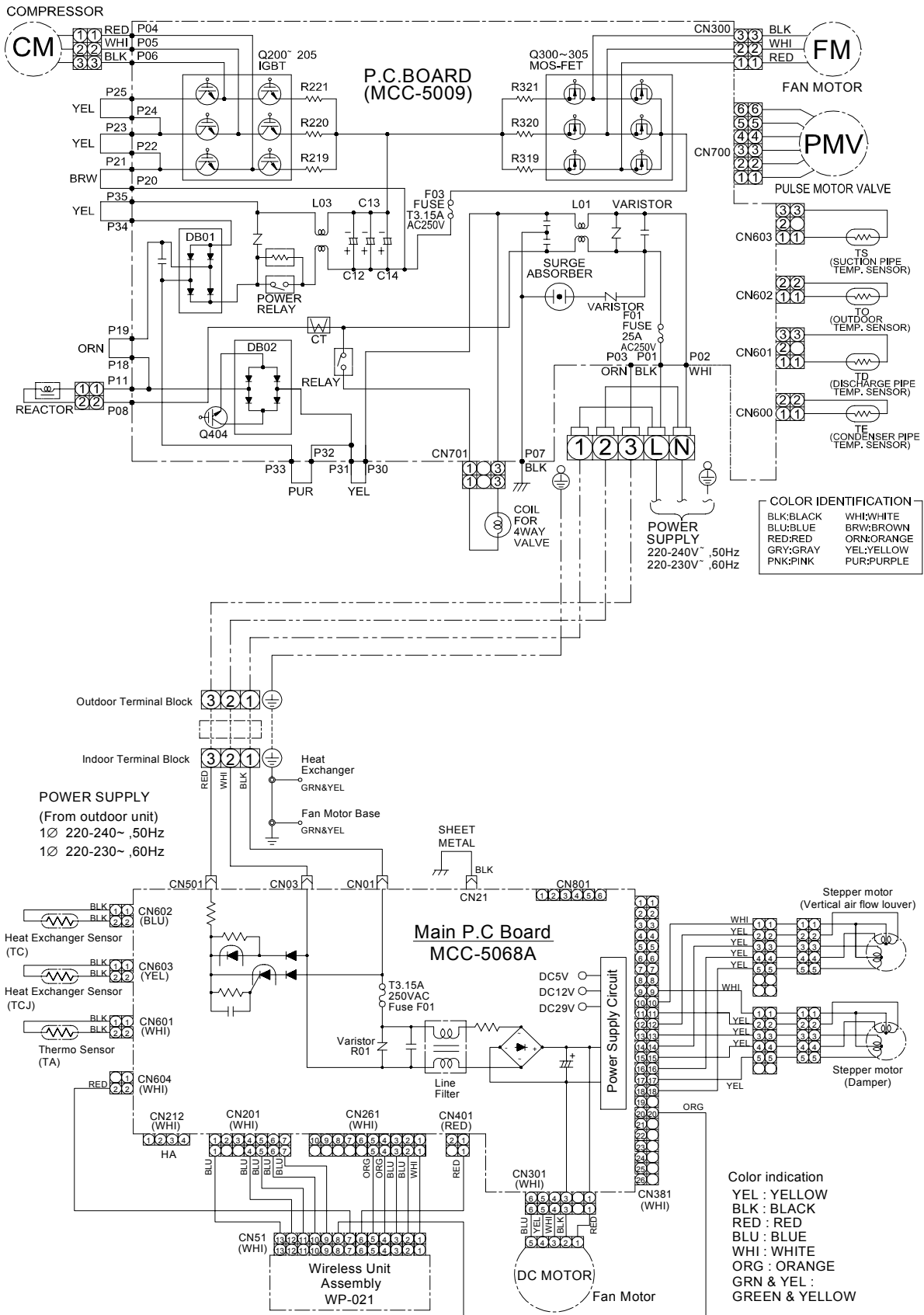

5-2. RAS-B18UFV-E / RAS-18SAV2-E

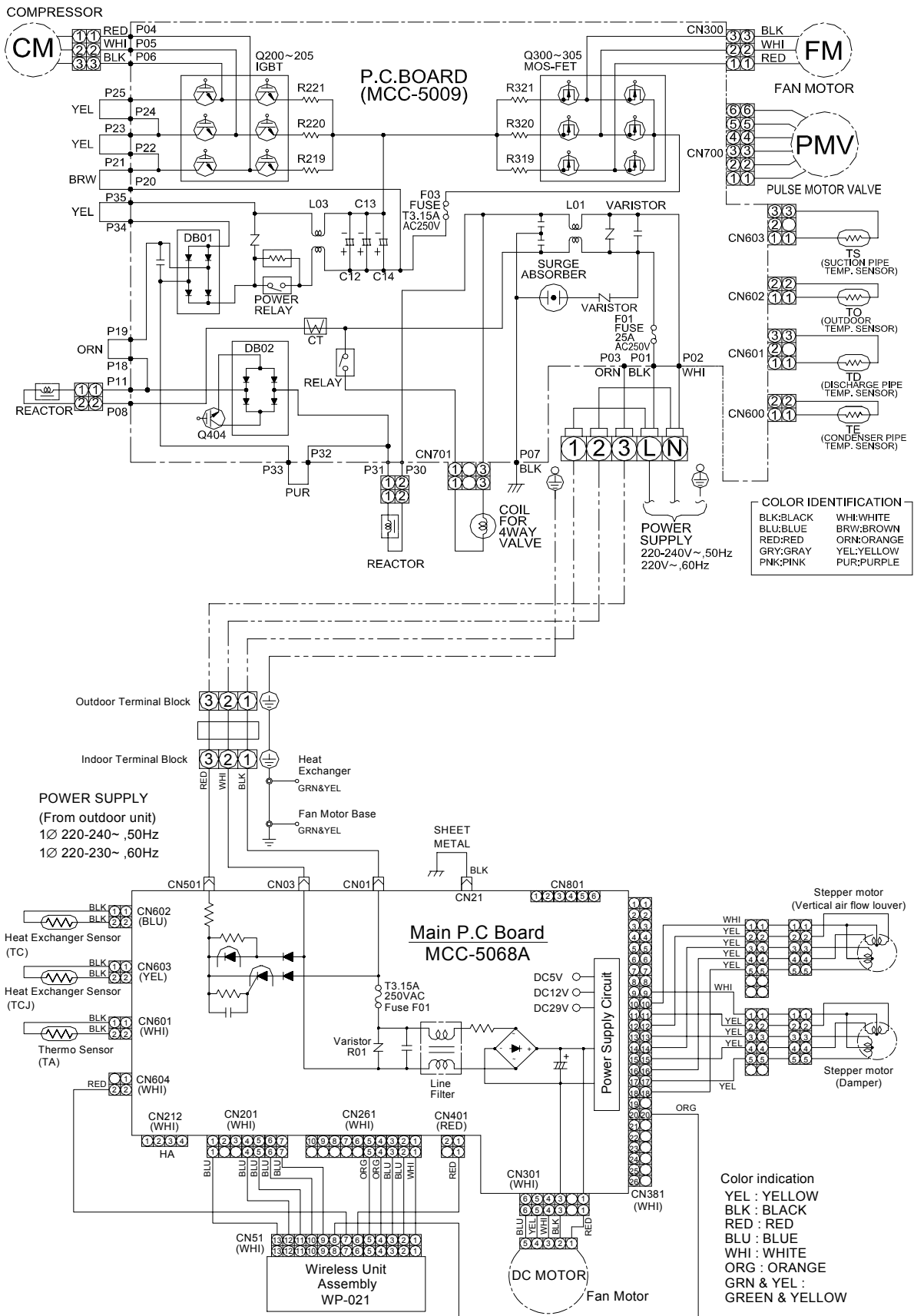

6. SPECIFICATIONS OF ELECTRICAL PARTS

6-1. Indoor Unit

No.	Parts name	Type	Specifications
1	Fan motor (for indoor)	ICF-340-41-1	DC340, 41W
2	Room temp. sensor (TA-sensor)	(-)	10kΩ at 25°C
3	Heat exchanger temp. sensor (TC-sensor)	(-)	10kΩ at 25°C
4	Heat exchanger temp. sensor (TCJ-sensor)	(-)	10kΩ at 25°C
5	Louver motor	MP24Z3T	Output (Rated) 1W, 16 poles, DC12V
6	Dumper motor	MP24Z3T	Output (Rated) 1W, 16 poles, DC12V

6-2. Outdoor Unit

No.	Parts name	Model name	Rating
1	Reactor	RAS-10SAV2-E, RAS-13SAV2-E	CH-69 L = 19mH, 10A
		RAS-18SAV2-E	CH-57 L = 10mH, 16A
2	Outdoor fan motor	ICF-140-43-4R	DC140V, 43W
3	Suction temp. sensor (TS sensor)	(Inverter attached)	10k (25°C)
4	Discharge temp. sensor (TD sensor)	(Inverter attached)	62k (20°C)
5	Outside air temp. sensor (TO sensor)	(Inverter attached)	10k (25°C)
6	Heat exchanger temp. sensor (TE sensor)	(Inverter attached)	10k (25°C)
7	Terminal block (5P)	—	AC250V, 20A
8	Compressor	RAS-10SAV2-E, RAS-13SAV2-E	DA89X1C-23FZ2 3-phases 4-poles
		RAS-18SAV2-E	DA130A1F-27F
9	Coil for PMV	CAM-MD12TCTH-5	DC12V
10	Coil for 4-way valve	STF-01AJ646A1	AC220-240V

7. REFRIGERANT CYCLE DIAGRAM

7-1. Refrigerant Cycle Diagram

RAS-B10UFV-E / RAS-10SAV2-E

RAS-B13UFV-E / RAS-13SAV2-E

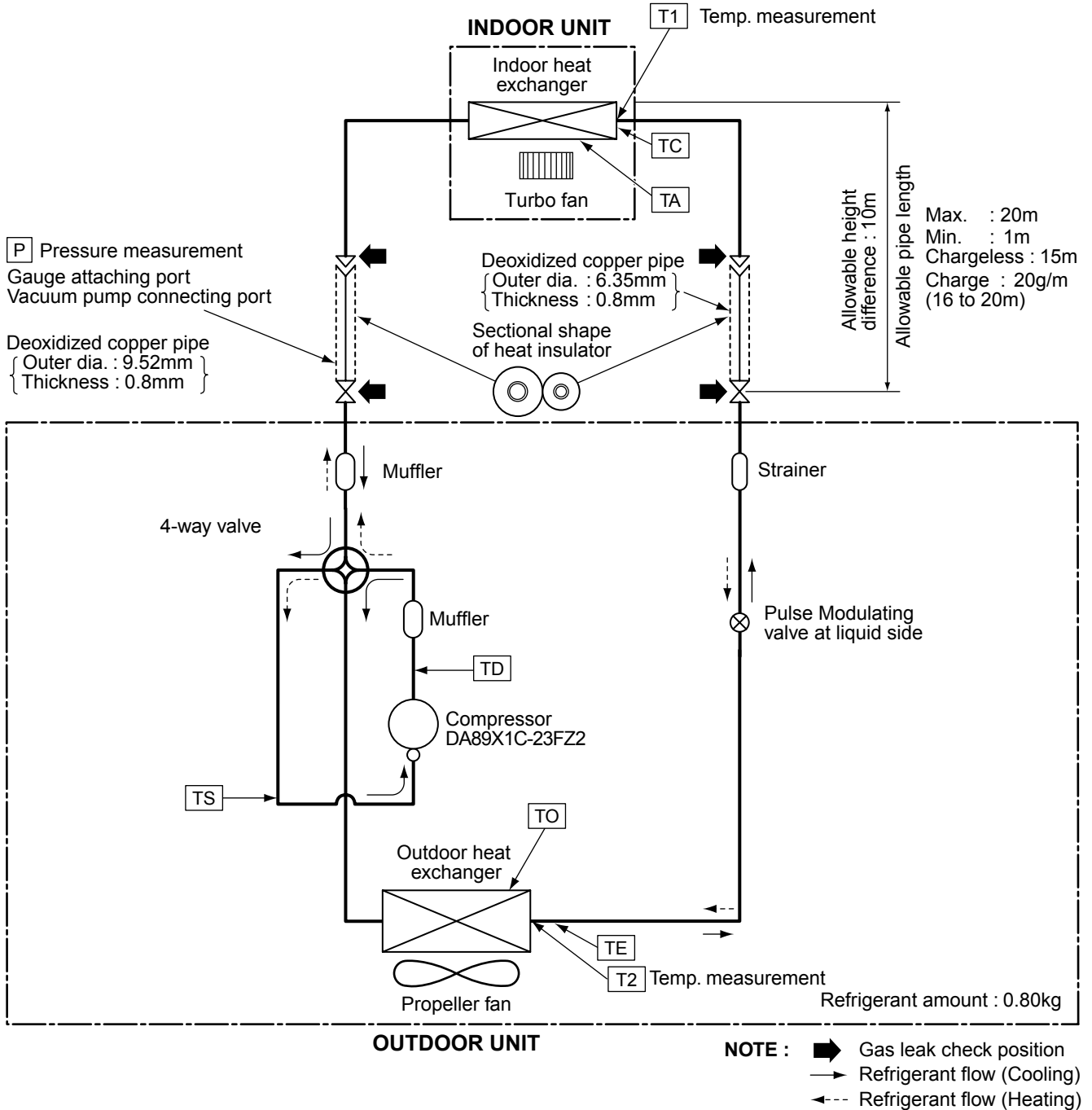

NOTE :

- The maximum pipe length of this air conditioner is 20 m. When the pipe length exceeds 15m, the additional charging of refrigerant, 20g per 1m for the part of pipe exceeded 15m is required. (Max. 100g)

7-2. Refrigerant Cycle Diagram

RAS-B18UFV-E / RAS-18SAV-E

RAS-B18UFV-E / RAS-18SAV2-E

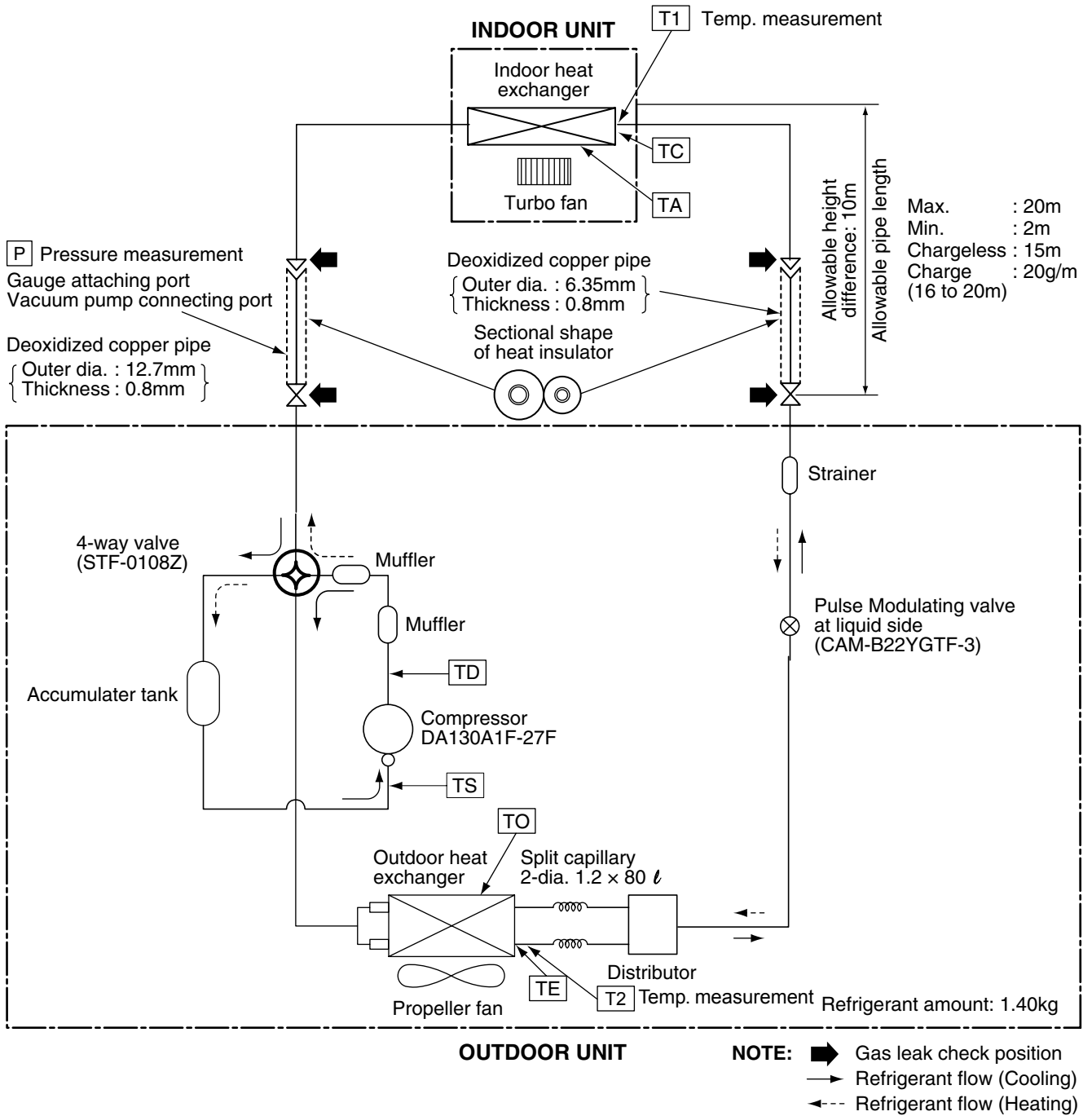

NOTE :

- The maximum pipe length of this air conditioner is 20m. When the pipe length exceeds 15m, the additional charging of refrigerant, 20g per 1m for the part of pipe exceeded 15m is required. (Max. 100g)

7-2. Operation Data

<Cooling>

Temperature condition(°C)		Model name RAS-	Standard pressure P (MPa)	Heat exchanger pipe temp.		Indoor fan mode	Outdoor fan mode	Compressor revolution (rps)
Indoor	Outdoor			T1 (°C)	T2 (°C)			
27/19	35/-	B10UFV-E	0.9 to 1.1	12 to 14	41 to 43	High	High	49
		B13UFV-E	0.8 to 1.0	10 to 12	39 to 41	High	High	74
		B18UFV-E	0.8 to 1.0	8 to 10	37 to 39	High	High	77

<Heating>

Temperature condition(°C)		Model name RAS-	Standard pressure P (MPa)	Heat exchanger pipe temp.		Indoor fan mode	Outdoor fan mode	Compressor revolution (rps)
Indoor	Outdoor			T1 (°C)	T2 (°C)			
20/-	7/6	B10UFV-E	2.1 to 2.3	37 to 39	2 to 4	High	High	62
		B13UFV-E	2.4 to 2.6	41 to 43	1 to 3	High	High	84
		B18UFV-E	2.9 to 3.0	49 to 51	1 to 3	High	High	75

NOTES :

1. Measure surface temperature of heat exchanger pipe around center of heat exchanger path U bent.
(Thermistor thermometer)
2. Connecting piping condition : 5 m (10k, 13k) and 7.5 m (18k)

8. CONTROL BLOCK DIAGRAM

8-1. Indoor Unit

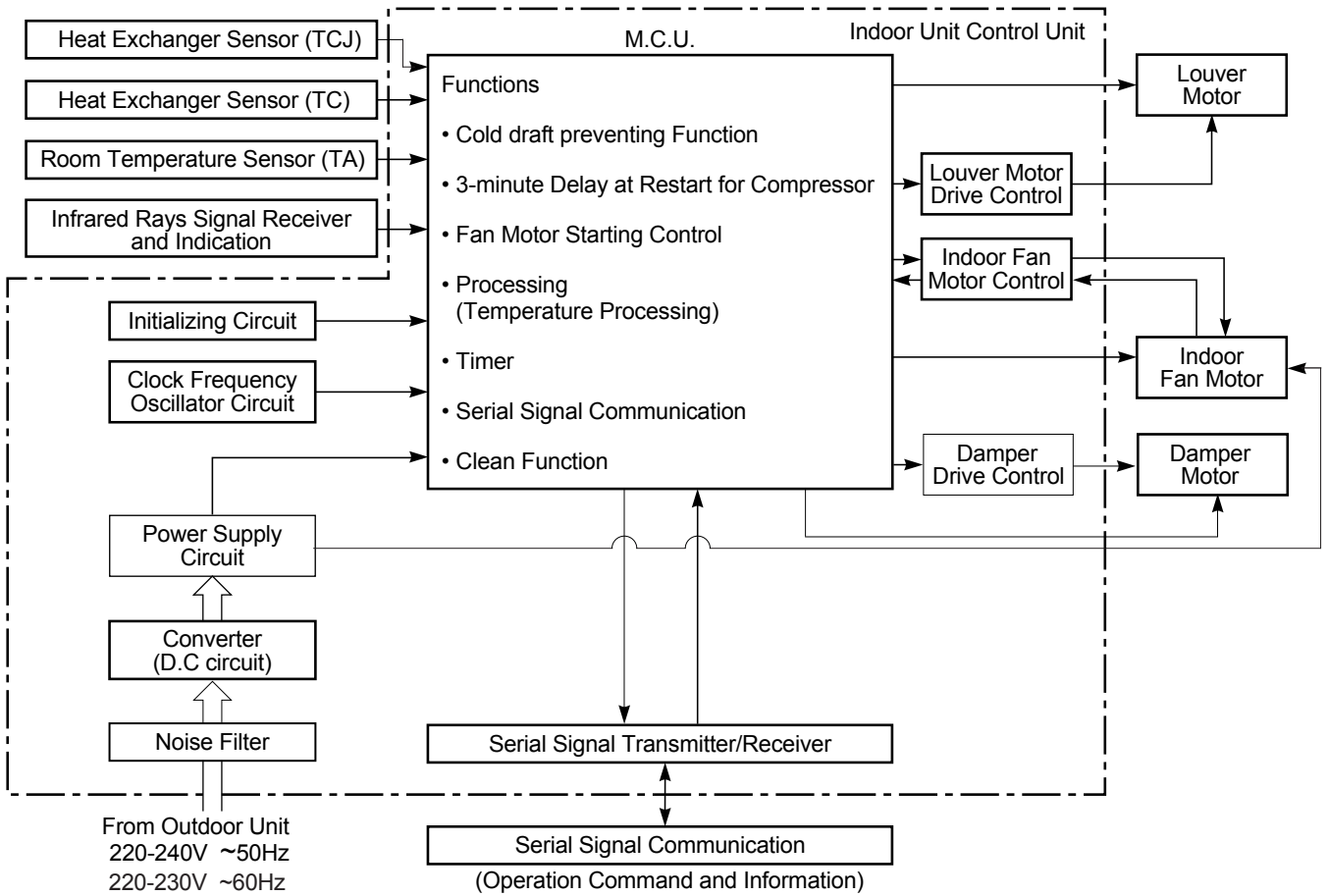

REMOTE CONTROL

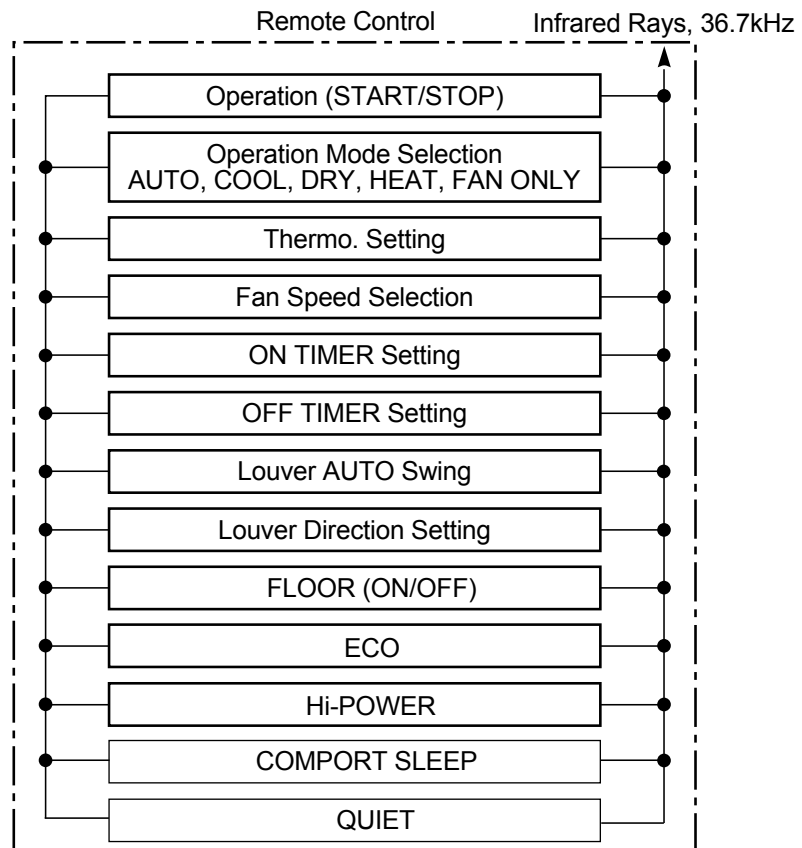

8-2. Outdoor Unit (Inverter Assembly)

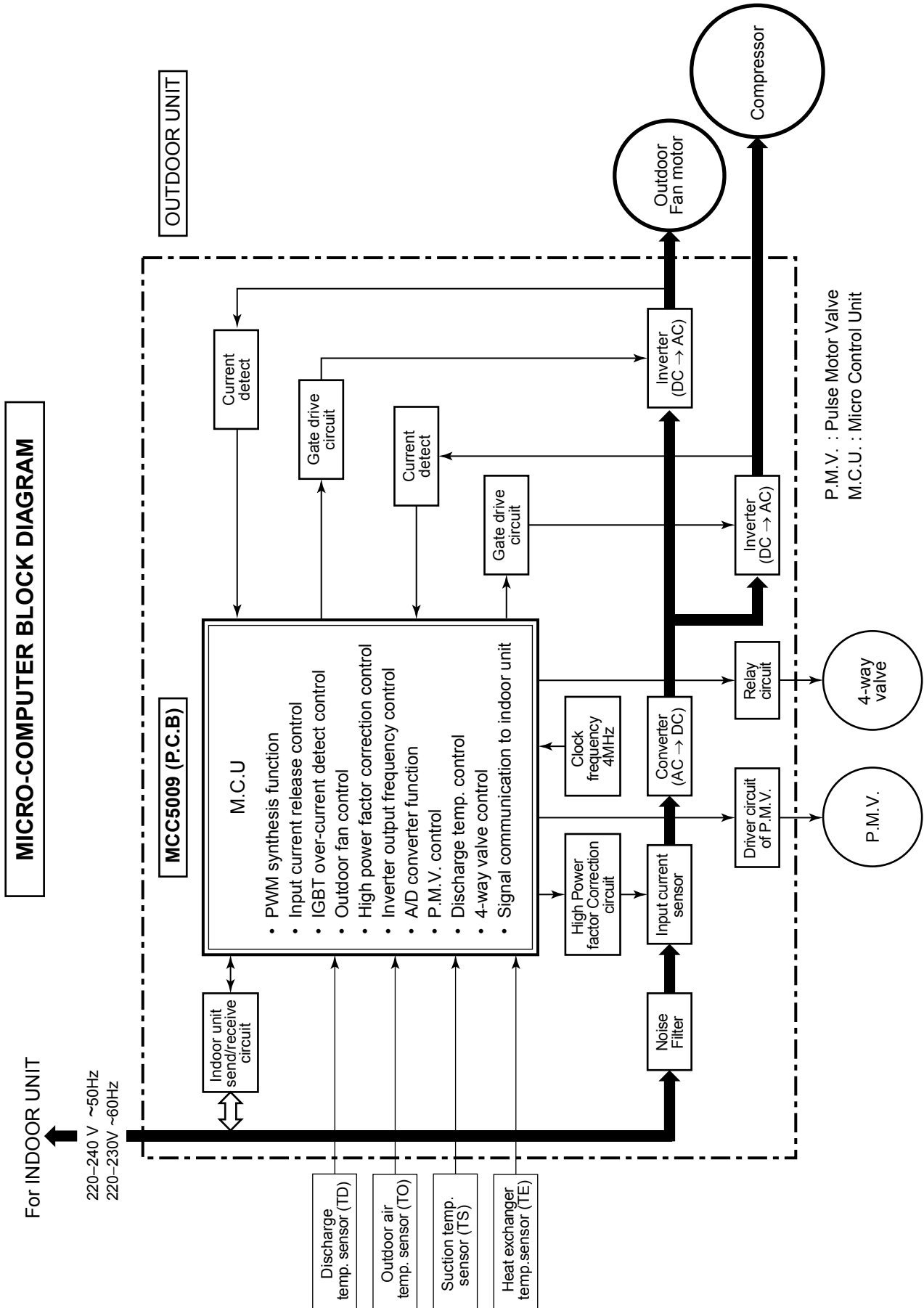

9. OPERATION DESCRIPTION

9-1. Outline of Air Conditioner Control

This air conditioner is a capacity-variable type air conditioner, which uses DC motor for the indoor fan motor and the outdoor fan motor. And the capacity-proportional control compressor which can change the motor speed is mounted. The DC motor drive circuit is mounted to the indoor unit. The compressor and the inverter to control fan motor are mounted to the outdoor unit.

The entire air conditioner is mainly controlled by the indoor unit controller.

The indoor unit controller drives the indoor fan motor based upon command sent from the remote controller or indoor unit display buttons and transfers the operation command to the outdoor unit controller.

The outdoor unit controller receives operation command from the indoor unit side, and controls the outdoor fan and the pulse Modulating valve. (P.M.V) Besides, detecting revolution position of the compressor motor, the outdoor unit controller controls speed of the compressor motor by controlling output voltage of the inverter and switching timing of the supply power (current transfer timing) so that motors drive according to the operation command.

And then, the outdoor unit controller transfers reversely the operating status information of the outdoor unit to control the indoor unit controller.

NOTE :

As the compressor adopts four-pole brushless DC motor, the frequency of the supply power from inverter to compressor is two-times cycles of the actual number of revolution.

1. Role of indoor unit controller

The indoor unit controller judges the operation commands from the remote control or indoor unit display buttons, and assumes the following functions.

- Judgment of suction air temperature of the indoor heat exchanger by using the indoor temp. sensor. (TA sensor)
- Judgment of the indoor heat exchanger temperature by using heat exchanger sensor (TC sensor) (Prevent-freezing control, etc.)
- Louver motor control
- Indoor fan motor operation control
- LED (Light Emitting Diode) display control
- Transferring of operation command signal (Serial signal) to the outdoor unit
- Reception of information of operation status (Serial signal including outside temp. data) to the outdoor unit and judgment/display of error

2. Role of outdoor unit controller

Receiving the operation command signal (Serial signal) from the indoor unit controller, the outdoor unit performs its role.

- Compressor operation control
- Operation control of outdoor fan motor
- P.M.V. control
- 4-way valve control
- Operations followed to judgment of serial signal from indoor side.

- Detection of inverter input current and current release operation
- Over-current detection and prevention operation to IGBT module (Compressor stop function)
- Compressor and outdoor fan stop function when serial signal is off (when the serial signal does not reach the board assembly of outdoor control by trouble of the signal system)
- Transferring of operation information (Serial signal) from outdoor unit controller to indoor unit controller
- Detection of outdoor temperature and operation revolution control
- Defrost control in heating operation (Temp. measurement by outdoor heat exchanger and control for 4-way valve and outdoor fan)

3. Contents of operation command signal (Serial signal) from indoor unit controller to outdoor unit controller

The following three types of signals are sent from the indoor unit controller.

- Operation mode set on the remote controller
- Compressor revolution command signal defined by indoor temperature and set temperature (Correction along with variation of room temperature and correction of indoor heat exchanger temperature are added.)
- Temperature of indoor heat exchanger
- For these signals ([Operation mode] and [Compressor revolution] indoor heat exchanger temperature), the outdoor unit controller monitors the input current to the inverter, and performs the followed operation within the range that current does not exceed the allowable value.

4. Contents of operation command signal (Serial signal) from outdoor unit controller to indoor unit controller

The following signals are sent from the outdoor unit controller.

- The current operation mode
 - The current compressor revolution
 - Outdoor temperature
 - Existence of protective circuit operation
- For transferring of these signals, the indoor unit controller monitors the contents of signals, and judges existence of trouble occurrence. Contents of judgment are described below.
- Whether distinction of the current operation status meets to the operation command signal
 - Whether protective circuit operates
- When no signal is received from the outdoor unit controller, it is assumed as a trouble.





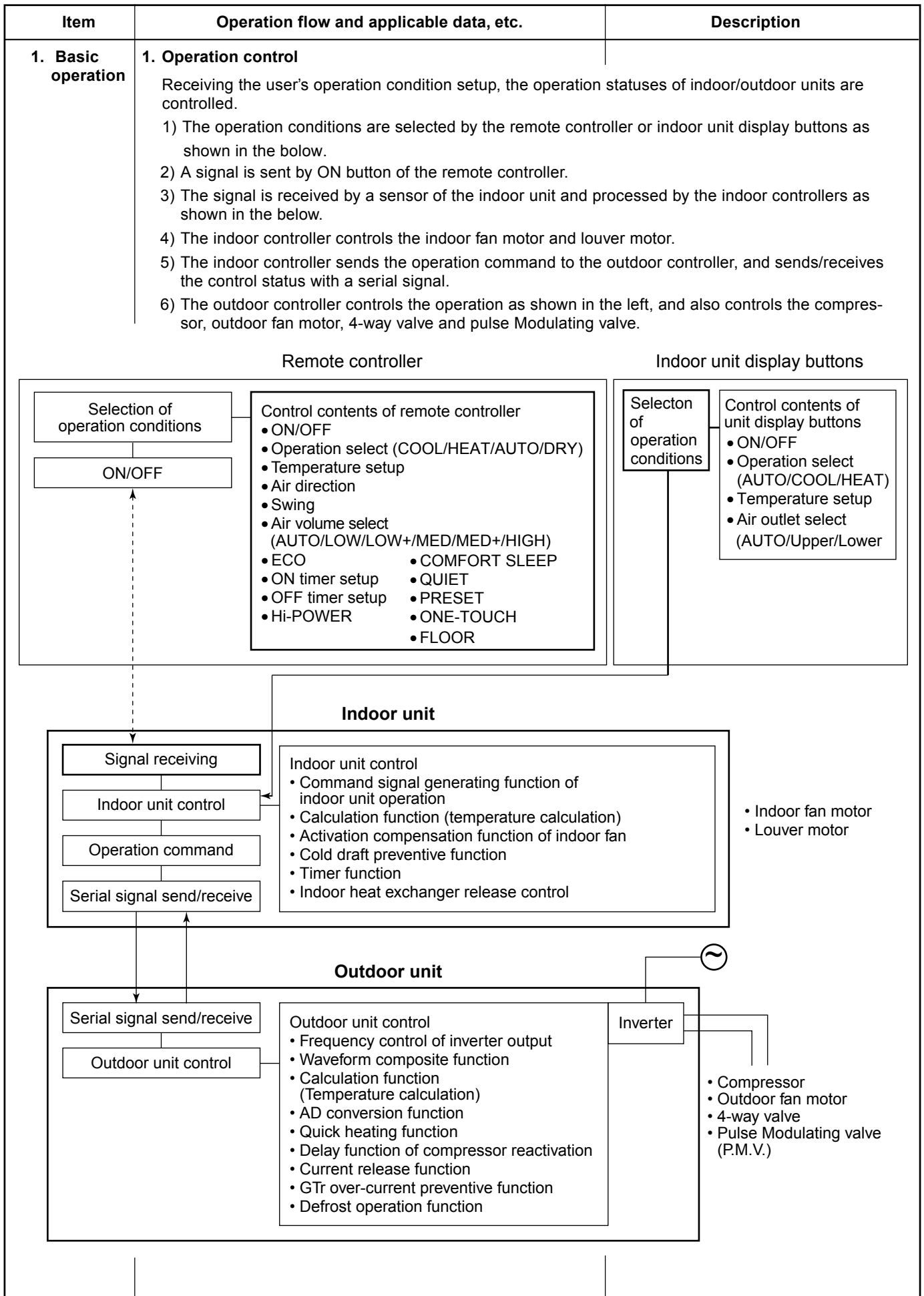

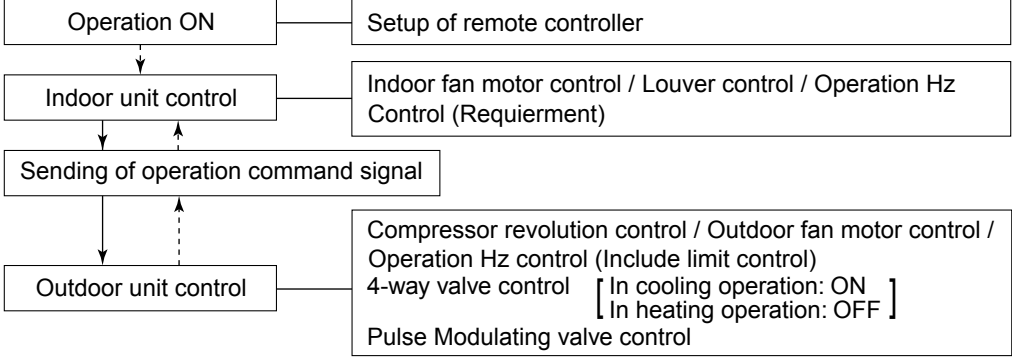
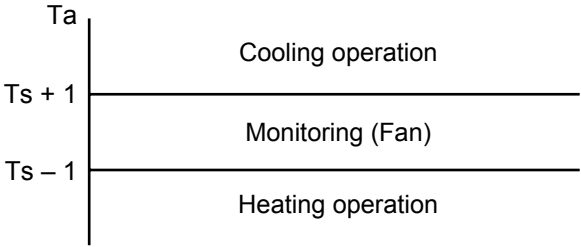

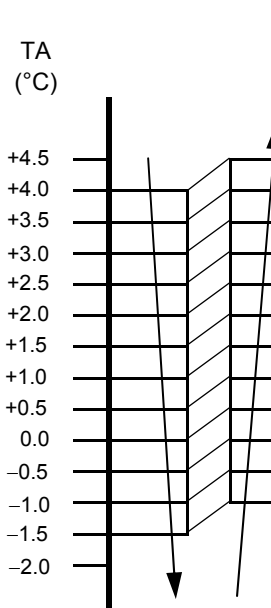

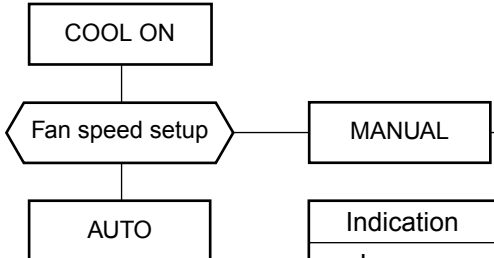



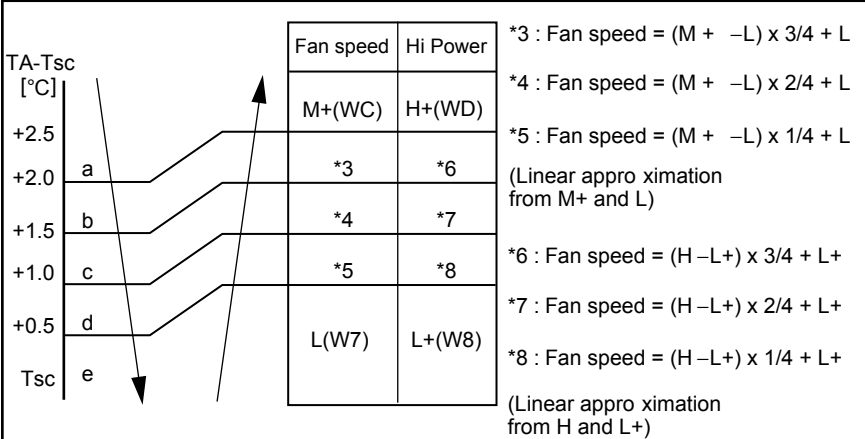

9-2. Operation Description

1. Basic operation	30
1. Operation control	30
2. Cooling/Heating operation	31
3. AUTO operation	31
4. DRY operation	32
2. Indoor fan motor control	33
3. Outdoor fan motor control	36
4. Capacity control	38
5. Current release control	38
6. Release protective control by temperature of indoor heat exchanger	39
7. Defrost control (Only in heating operation)	40
8. Air outlet selection	41
9. Lower air outlet louve control	42
10. Upper air outlet louver control	43
11. ECO operation	44
12. Test operation	45
13. Discharge temperature control	45
14. Pulse Modulating valve (P.M.V.) control	46
15. Self-Cleaning function	47
16. Self-Cleaning function release	48
17. Remote-A or B selection	49
18. QUIET mode	50
19. COMFORT SLEEP	50
20. Short Timer	50
21. One-Touch Comfort	51
22. Hi-POWER Mode	51
23. FILTER Indicator	51
24. Set temp. correction	52
25. Outdoor Quiet control	53
9-3. Auto Restart Function.....	55
9-3-1. How to Set the Auto Restart Function	55
9-3-2. How to Cancel the Auto Restart Function	56
9-3-3. Power Failure During Timer Operation	56
9-4. Remote Control	57
9-4-1. Remote control and its functions	57
9-4-2. Operation of remote control	57
9-4-3. Name and Functions of Indications on Remote Controller	63
9-5. Indoor Unit Display & Unit Operation Panel	64



Item	Operation flow and applicable data, etc.	Description
<p>1. Basic operation</p>	<p>2. Cooling/Heating operation</p> <p>The operations are performed in the following parts by controls according to cooling/heating conditions.</p> <ol style="list-style-type: none"> 1) Receiving the operation ON signal of the remote controller, the cooling or heating operation signal starts being transferred from the indoor controller to the outdoor unit. 2) At the indoor unit side, the indoor fan is operated according to the contents of “2. Indoor fan motor control” and the louver according to the contents of “9. Louver control”, respectively. 3) The outdoor unit controls the outdoor fan motor, compressor, pulse Modulating valve and 4-way valve according to the operation signal sent from the indoor unit. 	
	<p>3. AUTO operation</p> <p>Selection of operation mode As shown in the following figure, the operation starts by selecting automatically the status of room temperature (TA) when starting AUTO operation.</p> <p>*1. When reselecting the operation mode, the fan speed is controlled by the previous operation mode.</p> 	<ol style="list-style-type: none"> 1) Detects the room temperature (TA) when the operation started. 2) Selects an operation mode from TA in the left figure. 3) Fan operation continues until an operation mode is selected. 4) When AUTO operation has started within 2 hours after heating operation stopped and if the room temperature is 20°C or more, the fan operation is performed with "Super Ultra LOW" mode for 3 minutes. Then, select an operation mode. 5) If the status of compressor-OFF continues for 15 minutes the room temperature after selecting an operation mode (COOL/HEAT), reselect an operation mode.

Item	Operation flow and applicable data, etc.	Description																																																																															
<p>1. Basic operation</p>	<p>4. DRY operation</p> <p>DRY operation is performed according to the difference between room temperature and the setup temperature as shown below.</p> <p>In DRY operation, fan speed is controlled in order to prevent lowering of the room temperature.</p>	<p>1) Detects the room temperature (TA) when the DRY operation started.</p> <p>2) Starts operation under conditions in the left figure according to the temperature difference between the room temperature and the setup temperature (Tsc). Setup temperature (Tsc) = Set temperature on remote controller (Ts) + (-1.0 to 0.0)</p> <p>3) When the room temperature is lower 2°C or less than the setup temperature, turn off the compressor.</p> <p>4) The time correction is performed every 8 minutes.</p>																																																																															
 <table border="1" data-bbox="638 694 1340 1299"> <thead> <tr> <th rowspan="2">Zone</th> <th colspan="3">Compressor speed (rps)</th> <th rowspan="2">Fan speed</th> <th rowspan="2">Time correction</th> </tr> <tr> <th>B10UFV</th> <th>B13UFV</th> <th>B18UFV</th> </tr> </thead> <tbody> <tr> <td>12</td> <td>35</td> <td>37</td> <td>49</td> <td>W8</td> <td rowspan="6">+1 zone</td> </tr> <tr> <td>11</td> <td>32</td> <td>34</td> <td>42</td> <td>W6</td> </tr> <tr> <td>10</td> <td>30</td> <td>31</td> <td>36</td> <td></td> </tr> <tr> <td>9</td> <td>27</td> <td>28</td> <td>30</td> <td></td> </tr> <tr> <td>8</td> <td>25</td> <td>26</td> <td>24</td> <td></td> </tr> <tr> <td>7</td> <td>22</td> <td>23</td> <td>18</td> <td></td> </tr> <tr> <td>6</td> <td>20</td> <td>20</td> <td>11</td> <td></td> <td rowspan="3">±0</td> </tr> <tr> <td>5</td> <td></td> <td></td> <td></td> <td>W5</td> </tr> <tr> <td>4</td> <td></td> <td></td> <td></td> <td>W4</td> </tr> <tr> <td>3</td> <td></td> <td></td> <td></td> <td></td> <td rowspan="2">-1 zone (min 1)</td> </tr> <tr> <td>2</td> <td></td> <td></td> <td></td> <td></td> </tr> <tr> <td>1</td> <td></td> <td></td> <td></td> <td></td> <td></td> </tr> <tr> <td>0</td> <td>OFF</td> <td>OFF</td> <td>OFF</td> <td></td> <td></td> </tr> </tbody> </table>			Zone	Compressor speed (rps)			Fan speed	Time correction	B10UFV	B13UFV	B18UFV	12	35	37	49	W8	+1 zone	11	32	34	42	W6	10	30	31	36		9	27	28	30		8	25	26	24		7	22	23	18		6	20	20	11		±0	5				W5	4				W4	3					-1 zone (min 1)	2					1						0	OFF	OFF	OFF		
Zone	Compressor speed (rps)			Fan speed	Time correction																																																																												
	B10UFV	B13UFV	B18UFV																																																																														
12	35	37	49	W8	+1 zone																																																																												
11	32	34	42	W6																																																																													
10	30	31	36																																																																														
9	27	28	30																																																																														
8	25	26	24																																																																														
7	22	23	18																																																																														
6	20	20	11		±0																																																																												
5				W5																																																																													
4				W4																																																																													
3					-1 zone (min 1)																																																																												
2																																																																																	
1																																																																																	
0	OFF	OFF	OFF																																																																														

Item	Operation flow and applicable data, etc.	Description																																																																																																																																						
2. Indoor fan motor control	<p><In cooling operation> (This operation controls the fan speed at indoor unit side.) The indoor fan (cross flow fan) is operated by the phase-control induction motor. The fan rotates in 5 stages in MANUAL mode, and in 5 stages in AUTO mode, respectively. (Table 1)</p>	<p>* Symbols</p> <p>UH : Ultra High H : High M+ : Medium+ M : Medium L+ : Low+ L : Low L- : Low- UL : Ultra Low SUL : Super Ultra Low</p> <p>* The fan speed broadly varies due to position of the louver, etc. The described value indicates one under condition of inclining downward blowing.</p> <p>1) When setting the fan speed to L, L+, M, M+ or H on the remote controller, the operation is performed with the constant speed shown in Fig. 1.</p> <p>2) When setting the fan speed to AUTO on the remote controller, revolution of the fan motor is controlled to the fan speed level shown in Fig. 2 and Table 1 according to the setup temperature, room temperature, and heat exchanger temperature.</p>																																																																																																																																						
	 <p style="text-align: right;">(Fig. 1)</p> <table border="1" style="margin-left: auto; margin-right: auto;"> <thead> <tr> <th>Indication</th> <th>Fan speed</th> <th>Hi-POWER</th> </tr> </thead> <tbody> <tr> <td>L </td> <td>W7</td> <td>W8</td> </tr> <tr> <td>L+ </td> <td>(L + M) / 2</td> <td>(L + M) / 2</td> </tr> <tr> <td>M </td> <td>WA</td> <td>WC</td> </tr> <tr> <td>M+ </td> <td>(M + H) / 2</td> <td>(M + H) / 2</td> </tr> <tr> <td>H </td> <td>WD</td> <td>WE</td> </tr> </tbody> </table> <p style="text-align: center;">(Fig. 2)</p> 		Indication	Fan speed	Hi-POWER	L 	W7	W8	L+ 	(L + M) / 2	(L + M) / 2	M 	WA	WC	M+ 	(M + H) / 2	(M + H) / 2	H 	WD	WE																																																																																																																				
Indication	Fan speed	Hi-POWER																																																																																																																																						
L 	W7	W8																																																																																																																																						
L+ 	(L + M) / 2	(L + M) / 2																																																																																																																																						
M 	WA	WC																																																																																																																																						
M+ 	(M + H) / 2	(M + H) / 2																																																																																																																																						
H 	WD	WE																																																																																																																																						
<p>(table 1) Indoor fan air flow rate <Cooling></p> <table border="1" style="width: 100%; border-collapse: collapse;"> <thead> <tr> <th rowspan="2">Fan speed level</th> <th rowspan="2">Cool</th> <th colspan="2">RAS-B10UFV-E</th> <th colspan="2">RAS-B13UFV-E</th> <th colspan="2">RAS-B18UFV-E</th> </tr> <tr> <th>Fan speed (rpm)</th> <th>Air flow rate (m3/h)</th> <th>Fan speed (rpm)</th> <th>Air flow rate (m3/h)</th> <th>Fan speed (rpm)</th> <th>Air flow rate (m3/h)</th> </tr> </thead> <tbody> <tr><td>WF</td><td></td><td>530</td><td>498</td><td>560</td><td>528</td><td>650</td><td>624</td></tr> <tr><td>WE</td><td>UH</td><td>530</td><td>498</td><td>560</td><td>528</td><td>650</td><td>624</td></tr> <tr><td>WD</td><td>H</td><td>500</td><td>468</td><td>540</td><td>510</td><td>630</td><td>600</td></tr> <tr><td>WC</td><td>M+</td><td>440</td><td>408</td><td>460</td><td>426</td><td>560</td><td>528</td></tr> <tr><td>WB</td><td></td><td>440</td><td>408</td><td>460</td><td>426</td><td>560</td><td>528</td></tr> <tr><td>WA</td><td>M</td><td>380</td><td>342</td><td>390</td><td>354</td><td>500</td><td>468</td></tr> <tr><td>W9</td><td></td><td>340</td><td>300</td><td>350</td><td>312</td><td>450</td><td>414</td></tr> <tr><td>W8</td><td>L+</td><td>340</td><td>300</td><td>350</td><td>312</td><td>450</td><td>414</td></tr> <tr><td>W7</td><td>L</td><td>300</td><td>258</td><td>340</td><td>300</td><td>400</td><td>366</td></tr> <tr><td>W6</td><td>L-</td><td>260</td><td>216</td><td>270</td><td>228</td><td>360</td><td>324</td></tr> <tr><td>W5</td><td>UL</td><td>260</td><td>216</td><td>270</td><td>228</td><td>340</td><td>300</td></tr> <tr><td>W4</td><td></td><td>240</td><td>198</td><td>250</td><td>210</td><td>320</td><td>282</td></tr> <tr><td>W3</td><td>SUL</td><td>240</td><td>198</td><td>240</td><td>198</td><td>300</td><td>258</td></tr> <tr><td>W2</td><td></td><td>240</td><td>198</td><td>240</td><td>198</td><td>300</td><td>258</td></tr> <tr><td>W1</td><td></td><td>240</td><td>198</td><td>240</td><td>198</td><td>300</td><td>258</td></tr> </tbody> </table>			Fan speed level	Cool	RAS-B10UFV-E		RAS-B13UFV-E		RAS-B18UFV-E		Fan speed (rpm)	Air flow rate (m3/h)	Fan speed (rpm)	Air flow rate (m3/h)	Fan speed (rpm)	Air flow rate (m3/h)	WF		530	498	560	528	650	624	WE	UH	530	498	560	528	650	624	WD	H	500	468	540	510	630	600	WC	M+	440	408	460	426	560	528	WB		440	408	460	426	560	528	WA	M	380	342	390	354	500	468	W9		340	300	350	312	450	414	W8	L+	340	300	350	312	450	414	W7	L	300	258	340	300	400	366	W6	L-	260	216	270	228	360	324	W5	UL	260	216	270	228	340	300	W4		240	198	250	210	320	282	W3	SUL	240	198	240	198	300	258	W2		240	198	240	198	300	258	W1		240	198	240	198	300	258
Fan speed level	Cool	RAS-B10UFV-E			RAS-B13UFV-E		RAS-B18UFV-E																																																																																																																																	
		Fan speed (rpm)	Air flow rate (m3/h)	Fan speed (rpm)	Air flow rate (m3/h)	Fan speed (rpm)	Air flow rate (m3/h)																																																																																																																																	
WF		530	498	560	528	650	624																																																																																																																																	
WE	UH	530	498	560	528	650	624																																																																																																																																	
WD	H	500	468	540	510	630	600																																																																																																																																	
WC	M+	440	408	460	426	560	528																																																																																																																																	
WB		440	408	460	426	560	528																																																																																																																																	
WA	M	380	342	390	354	500	468																																																																																																																																	
W9		340	300	350	312	450	414																																																																																																																																	
W8	L+	340	300	350	312	450	414																																																																																																																																	
W7	L	300	258	340	300	400	366																																																																																																																																	
W6	L-	260	216	270	228	360	324																																																																																																																																	
W5	UL	260	216	270	228	340	300																																																																																																																																	
W4		240	198	250	210	320	282																																																																																																																																	
W3	SUL	240	198	240	198	300	258																																																																																																																																	
W2		240	198	240	198	300	258																																																																																																																																	
W1		240	198	240	198	300	258																																																																																																																																	

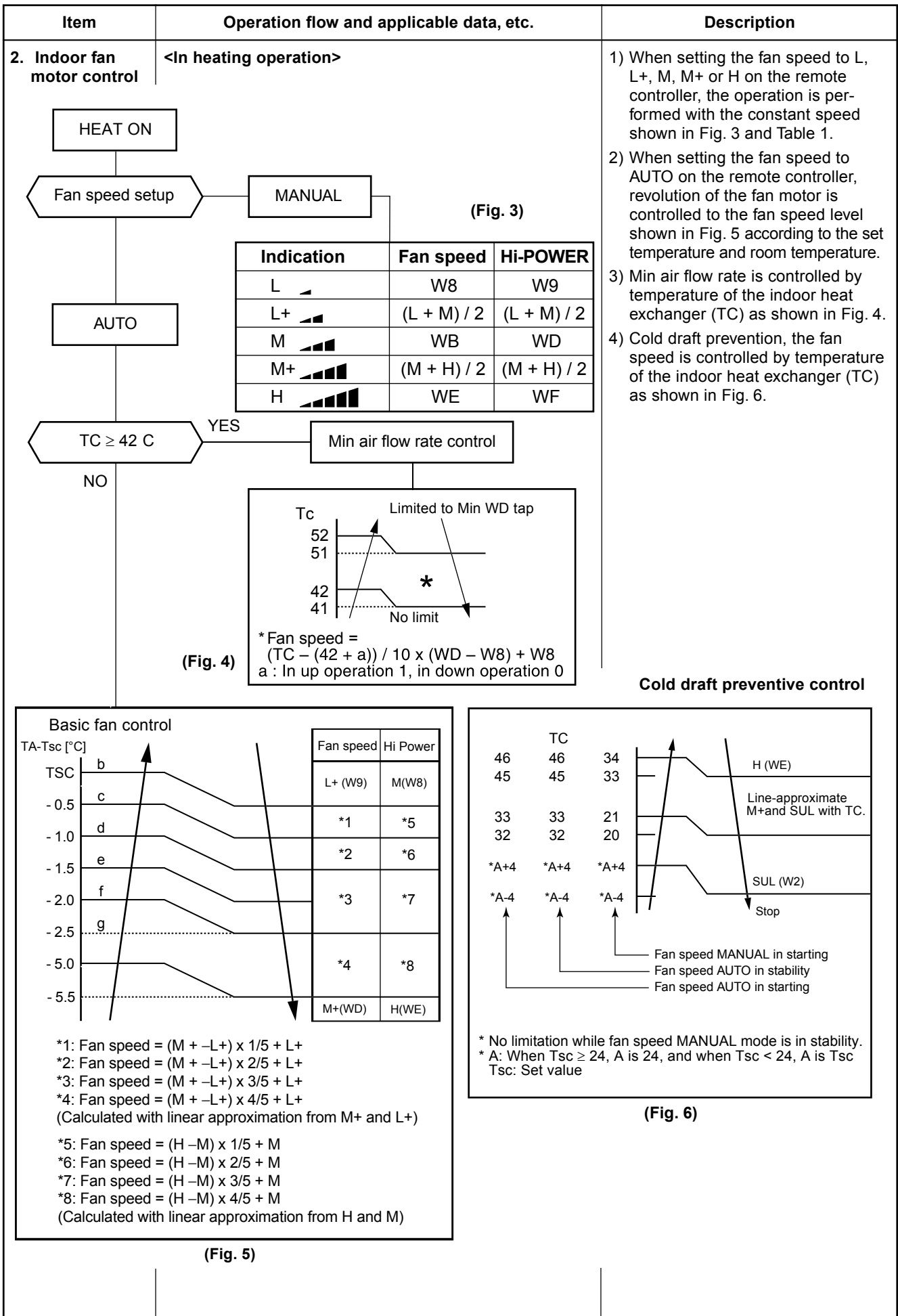

Item	Operation flow and applicable data, etc.		Description
[In starting and in stability]			
	In starting		In stability
FAN AUTO	<ul style="list-style-type: none"> • Until 12 minutes passed after operation start • When 12 to 25 minutes passed after operation start and room temp. is 3°C or lower than set temp. 		<ul style="list-style-type: none"> • When 12 to 25 minutes passed after operation start and room temp. is higher than (set temp. -3°C) • When 25 minutes or more passed after operation start
FAN Manual	• Room temp. < Set temp. -4°C		• Room temp. = Set temp. -3.5°C

(Table 2) Indoor fan air flow rate <Heating>

Fan speed level	HEAT	RAS-B10UFV-E		RAS-B13UFV-E		RAS-B18UFV-E	
		Fan speed (rpm)	Air flow rate (m3/h)	Fan speed (rpm)	Air flow rate (m3/h)	Fan speed (rpm)	Air flow rate (m3/h)
WF	UH	560	528	600	570	690	666
WE	H	540	510	580	552	670	642
WD	M+	500	468	520	486	600	570
WC		440	408	480	444	570	540
WB	M	380	342	390	354	520	486
WA		380	342	390	354	460	426
W9	L+	380	342	390	354	460	426
W8	L	300	258	350	312	400	366
W7	L-	260	216	340	300	360	324
W6		260	216	270	228	340	300
W5	UL	260	216	270	228	340	300
W4		260	216	270	228	340	300
W3		260	216	270	228	340	300
W2	SUL	240	198	250	210	320	282
W1		240	198	240	198	240	198

Item	Operation flow and applicable data, etc.	Description																																																																																																																																																	
3. Outdoor fan motor control	<p>The blowing air volume at the outdoor unit side is controlled. Receiving the operation command from the controller of indoor unit, the controller of outdoor unit controls fan speed.</p> <p>* For the fan motor, a DC motor with non-stage variable speed system is used. However, it is limited to 16 stages for reasons of controlling.</p> <p>10SAV2-E, 13SAV2-E</p> <table border="1" data-bbox="164 1375 828 1798"> <thead> <tr> <th colspan="2" rowspan="2"></th> <th colspan="6">In cooling operation</th> </tr> <tr> <th colspan="2">~ 13.8</th> <th colspan="2">~ 31.7</th> <th colspan="2">32.3 ~ MAX</th> </tr> <tr> <th rowspan="2">Compressor speed (rps)</th> <th rowspan="2">TO</th> <th>MIN</th> <th>MAX</th> <th>MIN</th> <th>MAX</th> <th>MIN</th> <th>MAX</th> </tr> </thead> <tbody> <tr> <td></td> <td>TO ≥ 38°C</td> <td>f 2</td> <td>f 3</td> <td>f C</td> <td>f D</td> <td>f E</td> <td>f F</td> </tr> <tr> <td></td> <td>TO ≥ 28°C</td> <td>f 2</td> <td>f 3</td> <td>f A</td> <td>f C</td> <td>f D</td> <td>f F</td> </tr> <tr> <td></td> <td>TO ≥ 15°C</td> <td>f 2</td> <td>f 3</td> <td>f 7</td> <td>f A</td> <td>f 9</td> <td>f C</td> </tr> <tr> <td></td> <td>TO ≥ 5.5°C</td> <td>f 1</td> <td>f 3</td> <td>f 2</td> <td>f 5</td> <td>f 4</td> <td>f 7</td> </tr> <tr> <td></td> <td>TO ≥ 0°C</td> <td>f 1</td> <td>f 1</td> <td>f 1</td> <td>f 2</td> <td>f 2</td> <td>f 4</td> </tr> <tr> <td></td> <td>TO < 0°C</td> <td>f 0</td> <td>f 0</td> <td>f 0</td> <td>f 1</td> <td>f 1</td> <td>f 2</td> </tr> <tr> <td rowspan="2">During ECO mode</td> <td>TO ≥ 38°C</td> <td>f 2</td> <td>f 3</td> <td>f B</td> <td>f C</td> <td>f C</td> <td>f D</td> </tr> <tr> <td>TO < 38°C</td> <td>f 2</td> <td>f 3</td> <td>f 2</td> <td>f 3</td> <td>f B</td> <td>f C</td> </tr> <tr> <td colspan="2">When TO is abnormal</td> <td>f D</td> <td>f F</td> <td>f D</td> <td>f F</td> <td>f D</td> <td>f F</td> </tr> </tbody> </table> <table border="1" data-bbox="858 1375 1417 1765"> <thead> <tr> <th colspan="2" rowspan="2"></th> <th colspan="3">In heating operation</th> </tr> <tr> <th>~16.8</th> <th>~47.9</th> <th>48.5 ~ MAX</th> </tr> <tr> <th rowspan="2">Compressor speed (rps)</th> <th rowspan="2">TO</th> <td>TO ≥ 15°C</td> <td>f 3</td> <td>f 8</td> <td>f 9</td> </tr> </thead> <tbody> <tr> <td></td> <td>TO < 15°C</td> <td>f 3</td> <td>f 9</td> <td>f A</td> </tr> <tr> <td></td> <td>TO < 5.5°C</td> <td>f 8</td> <td>f A</td> <td>f D</td> </tr> <tr> <td></td> <td>TO < -5.0°C</td> <td>f B</td> <td>f C</td> <td>f D</td> </tr> <tr> <td rowspan="3">During ECO mode</td> <td>TO ≥ 15°C</td> <td>f 3</td> <td>f 3</td> <td>f 6</td> </tr> <tr> <td>TO < 15°C</td> <td>f 3</td> <td>f 3</td> <td>f 8</td> </tr> <tr> <td>TO < 5.5°C</td> <td>f 5</td> <td>f 9</td> <td>f 9</td> </tr> <tr> <td></td> <td>TO < -5.5°C</td> <td>f 7</td> <td>f A</td> <td>f B</td> </tr> <tr> <td colspan="2">When TO is abnormal</td> <td>f A</td> <td>f B</td> <td>f D</td> </tr> </tbody> </table>			In cooling operation						~ 13.8		~ 31.7		32.3 ~ MAX		Compressor speed (rps)	TO	MIN	MAX	MIN	MAX	MIN	MAX		TO ≥ 38°C	f 2	f 3	f C	f D	f E	f F		TO ≥ 28°C	f 2	f 3	f A	f C	f D	f F		TO ≥ 15°C	f 2	f 3	f 7	f A	f 9	f C		TO ≥ 5.5°C	f 1	f 3	f 2	f 5	f 4	f 7		TO ≥ 0°C	f 1	f 1	f 1	f 2	f 2	f 4		TO < 0°C	f 0	f 0	f 0	f 1	f 1	f 2	During ECO mode	TO ≥ 38°C	f 2	f 3	f B	f C	f C	f D	TO < 38°C	f 2	f 3	f 2	f 3	f B	f C	When TO is abnormal		f D	f F	f D	f F	f D	f F			In heating operation			~16.8	~47.9	48.5 ~ MAX	Compressor speed (rps)	TO	TO ≥ 15°C	f 3	f 8	f 9		TO < 15°C	f 3	f 9	f A		TO < 5.5°C	f 8	f A	f D		TO < -5.0°C	f B	f C	f D	During ECO mode	TO ≥ 15°C	f 3	f 3	f 6	TO < 15°C	f 3	f 3	f 8	TO < 5.5°C	f 5	f 9	f 9		TO < -5.5°C	f 7	f A	f B	When TO is abnormal		f A	f B	f D	<ol style="list-style-type: none"> 1) The operation command sent from the remote controller is processed by the indoor unit controller and transferred to the controller of the outdoor unit. 2) When strong wind blows at outdoor side, the operation of air conditioner continues with the fan motor stopped. 3) Whether the fan is locked or not is detected, and the operation of air conditioner stops and an alarm is displayed if the fan is locked. 4) According to each operation mode, by the conditions of outdoor temperature (TO) and compressor revolution, the speed of the outdoor fan shown in the table is selected.
				In cooling operation																																																																																																																																															
		~ 13.8		~ 31.7		32.3 ~ MAX																																																																																																																																													
Compressor speed (rps)	TO	MIN	MAX	MIN	MAX	MIN	MAX																																																																																																																																												
			TO ≥ 38°C	f 2	f 3	f C	f D	f E	f F																																																																																																																																										
	TO ≥ 28°C	f 2	f 3	f A	f C	f D	f F																																																																																																																																												
	TO ≥ 15°C	f 2	f 3	f 7	f A	f 9	f C																																																																																																																																												
	TO ≥ 5.5°C	f 1	f 3	f 2	f 5	f 4	f 7																																																																																																																																												
	TO ≥ 0°C	f 1	f 1	f 1	f 2	f 2	f 4																																																																																																																																												
	TO < 0°C	f 0	f 0	f 0	f 1	f 1	f 2																																																																																																																																												
During ECO mode	TO ≥ 38°C	f 2	f 3	f B	f C	f C	f D																																																																																																																																												
	TO < 38°C	f 2	f 3	f 2	f 3	f B	f C																																																																																																																																												
When TO is abnormal		f D	f F	f D	f F	f D	f F																																																																																																																																												
		In heating operation																																																																																																																																																	
		~16.8	~47.9	48.5 ~ MAX																																																																																																																																															
Compressor speed (rps)	TO	TO ≥ 15°C	f 3	f 8	f 9																																																																																																																																														
			TO < 15°C	f 3	f 9	f A																																																																																																																																													
	TO < 5.5°C	f 8	f A	f D																																																																																																																																															
	TO < -5.0°C	f B	f C	f D																																																																																																																																															
During ECO mode	TO ≥ 15°C	f 3	f 3	f 6																																																																																																																																															
	TO < 15°C	f 3	f 3	f 8																																																																																																																																															
	TO < 5.5°C	f 5	f 9	f 9																																																																																																																																															
	TO < -5.5°C	f 7	f A	f B																																																																																																																																															
When TO is abnormal		f A	f B	f D																																																																																																																																															

Item	Operation flow and applicable data, etc.						Description		
18SAV-E, 18SAV2-E									
In cooling operation									
Compressor speed (rps)		< 22.1		< 50.3		50.3 ≤			
		MIN	MAX	MIN	MAX	MIN	MAX		
TO	TO ≥ 38°C	f6	f9	f8	fB	fA	fE		
	TO ≥ 28°C	f5	f9	f7	fB	f9	fE		
	TO ≥ 15°C	f3	f7	f5	f9	f7	fB		
	TO ≥ 5.5°C	f1	f3	f1	f7	f3	f9		
	TO ≥ 0°C	f1	f3	f1	f5	f3	f7		
	TO < 0°C	f0	f1	f0	f3	f1	f4		
During ECO, QUIET and comfort sleep	TO ≥ 38°C	f6	f9	f8	fB	fA	fB		
	TO ≥ 28°C	f5	f9	f7	fB	f9	fB		
	TO ≥ 15°C	f3	f7	f5	f9	f7	fB		
	TO ≥ 5.5°C	f1	f3	f1	f7	f3	f9		
	TO ≥ 0°C	f1	f3	f1	f5	f3	f7		
	TO < 0°C	f0	f1	f0	f3	f1	f4		
When TO is abnormal		f1	fF	f1	fF	f1	fF		
In heating operation									
Compressor speed (rps)		< 30.5		< 55.1		55.1 ≤			
TO	TO ≥ 10°C	f6	f8	f9					
	TO ≥ 5.5°C	f9	fA	fC					
	TO ≥ -5.0°	fA	fB	fD					
	TO < -5.0°C	fA	fB	fD					
During ECO mode	TO ≥ 10°C	f5	f7	f9					
	TO ≥ 5.5°C	f7	f9	fB					
	TO ≥ -5.0°C	f9	fA	fB					
When TO is abnormal		fD	fD	fD					
Outdoor fan speed (rpm)									
Tap	10SAV2-E	13SAV2-E	18SAV-E	18SAV2-E	Tap	10SAV2-E	13SAV2-E	18SAV-E	18SAV2-E
f 0	0	0	0	0	f 9	600	650	640	640
f 1	200	200	230	230	f A	600	700	700	700
f 2	300	300	300	300	f B	650	700	700	700
f 3	370	370	350	350	f C	700	800	800	900
f 4	440	440	410	410	f D	700	800	800	900
f 5	440	440	480	480	f E	700	800	800	900
f 6	500	500	500	500	f F	700	800	800	900
f 7	550	550	530	530					
f 8	600	600	560	560					

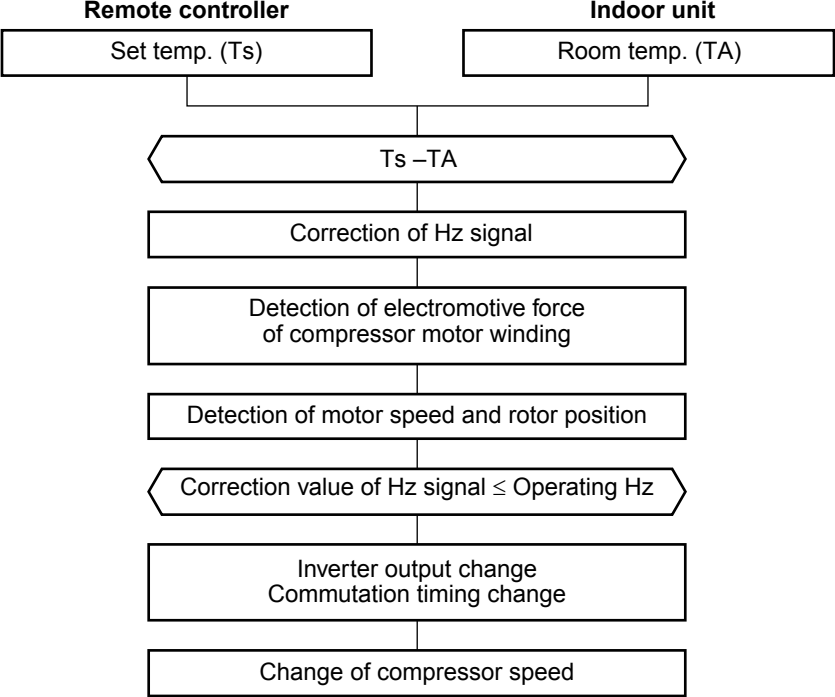
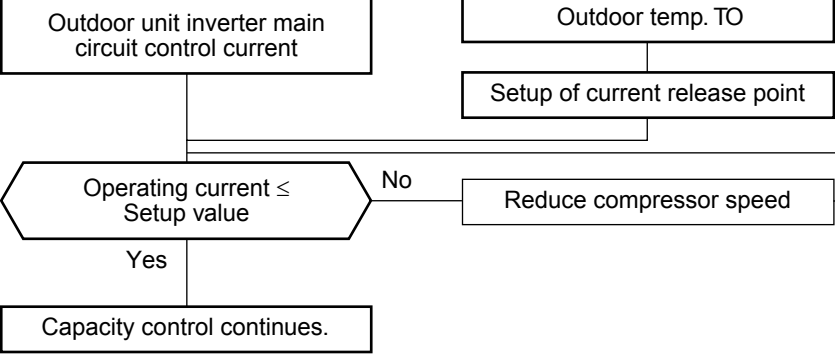
Item	Operation flow and applicable data, etc.	Description																																						
<p>4. Capacity control</p>	<p>The cooling or heating capacity depending on the load is adjusted.</p> <p>According to difference between the setup value of temperature and the room temperature, the capacity is adjusted by the compressor revolution.</p> 	<ol style="list-style-type: none"> 1) The difference between set temperature on remote controller (Ts) and room temperature (TA) is calculated. 2) According to the temperature difference, the correction value of Hz signal which determines the compressor speed is set up. 3) The rotating position and speed of the motor are detected by the electromotive force occurred on the motor winding with operation of the compressor. 4) According to the difference resulted from comparison of the correction value of Hz signal with the present operation Hz, the inverter output and the commutation timing are varied. 5) Change the compressor motor speed by outputting power to the compressor. <p>* The contents of control operation are same in cooling operation and heating operation</p>																																						
<p>5. Current release control</p>	<p>This function prevents troubles on the electronic parts of the compressor driving inverter.</p> <p>This function also controls drive circuit of the compressor speed so that electric power of the compressor drive circuit does not exceed the specified value.</p> 	<ol style="list-style-type: none"> 1) The input current of the outdoor unit is detected in the inverter section of the outdoor unit. 2) According to the detected outdoor temperature, the specified value of the current is selected. 3) Whether the current value exceeds the specified value or not is judged. 4) If the current value exceeds the specified value, this function reduces the compressor speed and controls speed up to the closest one commanded from the indoor unit within the range which does not exceed the specified value. 																																						
<table border="1"> <thead> <tr> <th rowspan="2">Outdoor temp.</th> <th colspan="3">Cooling current release value</th> <th colspan="3">Heating current release value</th> </tr> <tr> <th>10SAV2-E</th> <th>13SAV2-E</th> <th>18SAV-E 18SAV2-E</th> <th>10SAV2-E</th> <th>13SAV2-E</th> <th>18SAV-E 18SAV2-E</th> </tr> </thead> <tbody> <tr> <td>45°C</td> <td rowspan="2">3.97A</td> <td rowspan="2">4.27A</td> <td rowspan="2">6.07A</td> <td rowspan="3">6.30A</td> <td rowspan="3">6.30A</td> <td rowspan="3">8.77A</td> </tr> <tr> <td>40°C</td> <td>4.35A</td> <td>4.88A</td> <td>7.12A</td> </tr> <tr> <td>16°C</td> <td>6.30A</td> <td>6.30A</td> <td>8.47A</td> </tr> <tr> <td>11°C</td> <td rowspan="2">6.30A</td> <td rowspan="2">6.30A</td> <td rowspan="2">8.47A</td> <td>6.30A</td> <td>6.30A</td> <td rowspan="2">8.77A</td> </tr> <tr> <td>10.5°C</td> <td>6.30A</td> <td>6.30A</td> </tr> </tbody> </table>			Outdoor temp.	Cooling current release value			Heating current release value			10SAV2-E	13SAV2-E	18SAV-E 18SAV2-E	10SAV2-E	13SAV2-E	18SAV-E 18SAV2-E	45°C	3.97A	4.27A	6.07A	6.30A	6.30A	8.77A	40°C	4.35A	4.88A	7.12A	16°C	6.30A	6.30A	8.47A	11°C	6.30A	6.30A	8.47A	6.30A	6.30A	8.77A	10.5°C	6.30A	6.30A
Outdoor temp.	Cooling current release value			Heating current release value																																				
	10SAV2-E	13SAV2-E	18SAV-E 18SAV2-E	10SAV2-E	13SAV2-E	18SAV-E 18SAV2-E																																		
45°C	3.97A	4.27A	6.07A	6.30A	6.30A	8.77A																																		
40°C							4.35A	4.88A	7.12A																															
16°C	6.30A	6.30A	8.47A																																					
11°C	6.30A	6.30A	8.47A	6.30A	6.30A	8.77A																																		
10.5°C				6.30A	6.30A																																			

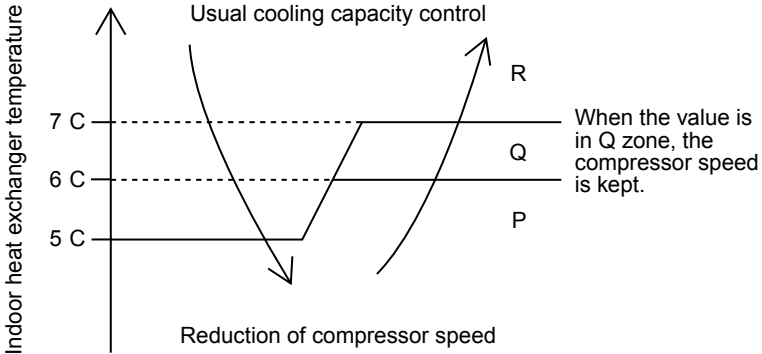
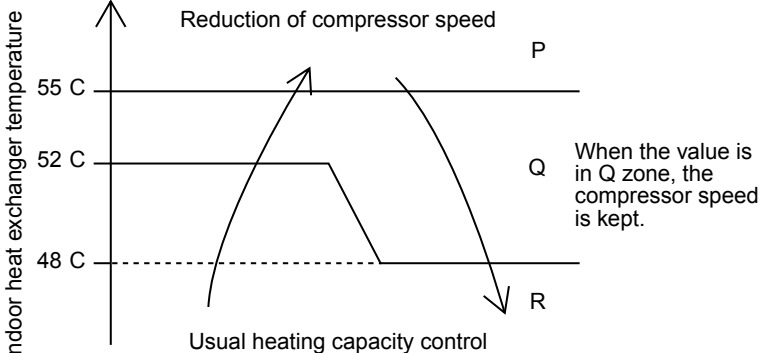
Item	Operation flow and applicable data, etc.	Description
<p>6. Release protective control by temperature of indoor heat exchanger</p>	<p><In cooling/dry operation> (Prevent-freezing control for indoor heat exchanger) In cooling/dry operation, the sensor of indoor heat exchanger detects evaporation temperature and controls the compressor speed so that temperature of the heat exchanger does not exceed the specified value.</p> 	<ol style="list-style-type: none"> 1) When temperature of the indoor heat exchanger drops below 5°C, the compressor speed is reduced. (P zone) 2) When temperature of the indoor heat exchanger rises in the range from 6°C to under 7°C, the compressor speed is kept. (Q zone) 3) When temperature of the indoor heat exchanger rises to 7°C or higher, the capacity control operation returns to the usual control in cooling operation. (R zone)
	<p><In heating operation> (Prevent-overpressure control for refrigerating cycle) In heating operation, the sensor of indoor heat exchanger detects condensation temperature and controls the compressor speed so that temperature of the heat exchanger does not exceed the specified value.</p> 	<ol style="list-style-type: none"> 1) When temperature of the indoor heat exchanger rises in the range from 50°C to 55°C, the compressor speed is kept. (Q zone) When temperature of the indoor heat exchanger drops in the range from 46°C to under 55°C, the compressor speed is kept. (Q zone) 2) When temperature of the indoor heat exchanger rises to 55°C or higher, the compressor speed is reduced. (P zone) 3) When temperature of the indoor heat exchanger does not rise to 50°C, or when it drops below to 46°C, the capacity control operation returns to the usual control in heating operation. (R zone)

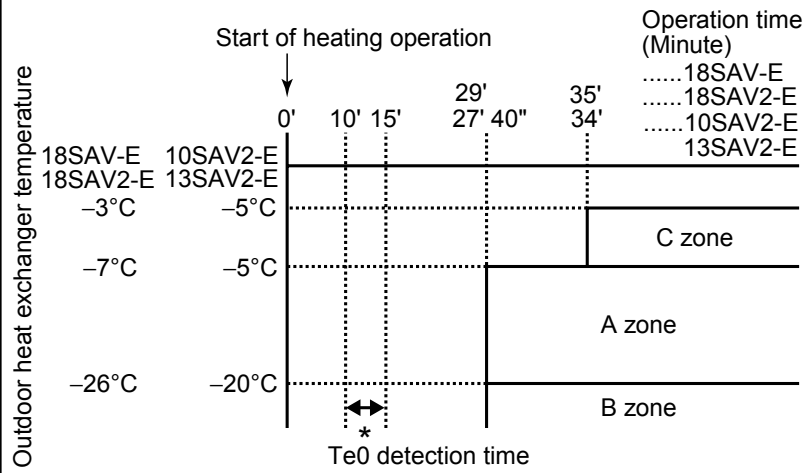
Item	Operation flow and applicable data, etc.	Description								
<p>7. Defrost control (Only in heating operation)</p>	<p>(This function removes frost adhered to the outdoor heat exchanger.)</p> <p>The temperature sensor of the outdoor heat exchanger (TE sensor) judges the frosting status of the outdoor heat exchanger and the defrost operation is performed with 4-way valve reverse defrost system.</p>  <p style="text-align: center;">* The minimum value of Te sensor 10 to 15 minutes after start of operation is stored in memory as Te0.</p> <p style="text-align: center;">Table 1</p> <table border="1" data-bbox="172 1041 938 1249"> <thead> <tr> <th>Zone</th> <th>Condition</th> </tr> </thead> <tbody> <tr> <td>A zone</td> <td>When $Te_0 - TE = 2.5$ continued for 2 minutes in A zone, defrost operation starts.</td> </tr> <tr> <td>B zone</td> <td>When the operation continued for 2 minutes in B zone, defrost operation starts.</td> </tr> <tr> <td>C zone</td> <td>When $Te_0 - TE = 3$ continued for 2 minutes in C zone, defrost operation starts.</td> </tr> </tbody> </table>	Zone	Condition	A zone	When $Te_0 - TE = 2.5$ continued for 2 minutes in A zone, defrost operation starts.	B zone	When the operation continued for 2 minutes in B zone, defrost operation starts.	C zone	When $Te_0 - TE = 3$ continued for 2 minutes in C zone, defrost operation starts.	<p>The necessity of defrost operation is detected by the outdoor heat exchanger temperature. The conditions to detect the necessity of defrost operation differ in A, B, or C zone each. (Table 1)</p> <p><Defrost operation></p> <ul style="list-style-type: none"> Defrost operation in A to C zones <ol style="list-style-type: none"> 1) Stop operation of the compressor for 20 seconds. 2) Invert (ON) 4-way valve 10 seconds after stop of the compressor. 3) The outdoor fan stops at the same time when the compressor stops. 4) When temperature of the indoor heat exchanger becomes 38°C or lower, stop the indoor fan. <p><Finish of defrost operation></p> <ul style="list-style-type: none"> Returning conditions from defrost operation to heating operation <ol style="list-style-type: none"> 1) Temperature of outdoor heat exchanger rises to +8°C or higher. 2) Temperature of outdoor heat exchanger is kept at +5°C or higher for 80 seconds. 3) Defrost operation continues for 15 minutes. <p><Returning from defrost operation></p> <ol style="list-style-type: none"> 1) Stop operation of the compressor for approx. 50 seconds. 2) Invert (OFF) 4-way valve approx. 40 seconds after stop of the compressor. 3) The outdoor fan starts rotating at the same time when the compressor starts.
Zone	Condition									
A zone	When $Te_0 - TE = 2.5$ continued for 2 minutes in A zone, defrost operation starts.									
B zone	When the operation continued for 2 minutes in B zone, defrost operation starts.									
C zone	When $Te_0 - TE = 3$ continued for 2 minutes in C zone, defrost operation starts.									

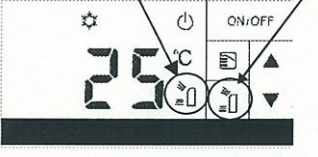
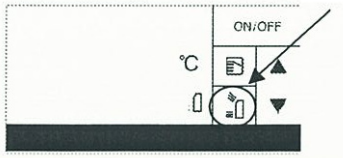
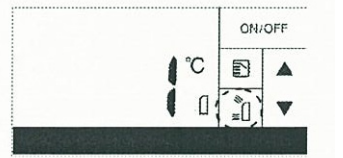
Item	Operation flow and applicable data,etc	Description																											
<p>8. Air outlet selection</p>	<p>< How to change air outlet selection ></p> <ol style="list-style-type: none"> Operate the air conditioner and select cooling or heating mode. (Air outlet selection can't be changed at standby mode.) Push AIR OUTLET SELECT button on the unit operation panel to change air outlet selection. <p>AIR OUTLET indication AIR OUTLET SELECT button</p>  <p>Air outlet is controlled as below.</p> <table border="1" data-bbox="159 728 981 1400"> <thead> <tr> <th rowspan="2">AIR OUTLET indicator</th> <th colspan="4">Mode</th> </tr> <tr> <th colspan="2">Cooling</th> <th>Dry mode</th> <th colspan="2">Heating</th> </tr> </thead> <tbody> <tr> <td>Bi-flow</td> <td>$TA > T_{sc} + 1^{\circ}C$</td> <td>$TA \leq T_{sc} + 1^{\circ}C$ or ($TA \leq T_{sc} + 1.5$ and after 1 hour running)</td> <td rowspan="2" style="text-align: center;">/</td> <td>$TC < 33^{\circ}C$</td> <td>$TC \geq 33^{\circ}C$</td> </tr> <tr> <td>Upper flow</td> <td colspan="2" style="text-align: center;">/</td> <td colspan="2" style="text-align: center;">/</td> </tr> <tr> <td>Lower-flow</td> <td colspan="2" style="text-align: center;">/</td> <td colspan="2" style="text-align: center;">/</td> <td style="text-align: center;">/</td> </tr> </tbody> </table>	AIR OUTLET indicator	Mode				Cooling		Dry mode	Heating		Bi-flow	$TA > T_{sc} + 1^{\circ}C$	$TA \leq T_{sc} + 1^{\circ}C$ or ($TA \leq T_{sc} + 1.5$ and after 1 hour running)	/	$TC < 33^{\circ}C$	$TC \geq 33^{\circ}C$	Upper flow	/		/		Lower-flow	/		/		/	<ol style="list-style-type: none"> Purpose Description <ul style="list-style-type: none"> In Cooling operation, only lower-flow can't be selected. In Dry mode operation, bi-flow and lower-flow can't be selected. In heating operation and bi-flow setting, the air outlet is set only upper flow for preventing cold draft when the indoor heat exchanger sensor temperature (TC) is lower than 33 degrees. In cooling operation and bi-flow setting, the air outlet is set only upper flow for preventing the room from overcooling when the room temperature (TA) is nearing the setup temperature. This function can be cancelled to change setting.
AIR OUTLET indicator	Mode																												
	Cooling		Dry mode	Heating																									
Bi-flow	$TA > T_{sc} + 1^{\circ}C$	$TA \leq T_{sc} + 1^{\circ}C$ or ($TA \leq T_{sc} + 1.5$ and after 1 hour running)	/	$TC < 33^{\circ}C$	$TC \geq 33^{\circ}C$																								
Upper flow	/			/																									
Lower-flow	/		/		/																								
	<p>< How to cancel to change upper-flow at Bi-flow setting in cooling ></p> <ol style="list-style-type: none"> Stop operation. Push and hold AIR OUTLET SELECT button on the unit operation panel over 10seconds (less than 20seconds). <p>AIR OUTLET SELECT button</p>  <ol style="list-style-type: none"> After holding 10seconds, 4 beep sounds in heard and TEMPERATURE indicator displays "1" for 5seconds. Release AIR OUTLET SELECT button. 																												

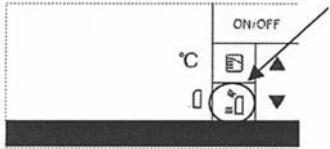
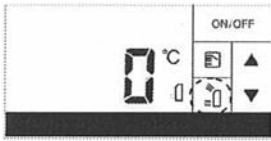
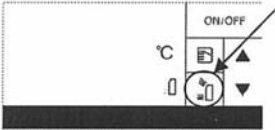
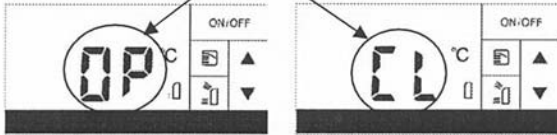
Item	Operation flow and applicable data,etc	Description															
<p>8. Air outlet selection</p>	<p>< How to set to change upper-flow at Bi-flow setting in cooling</p> <ol style="list-style-type: none"> 1. Stop operation. 2. Push and hold AIR OUTLET SELECT button on the unit operation panel over 10seconds (less than 20seconds). <p style="text-align: center;">AIR OUTLET SELECT button</p>  <ol style="list-style-type: none"> 3. After holding 10seconds, 4 beep sounds in heard and TEMPERATURE indicator displays "1" for 5seconds. Release AIR OUTLET SELECT button. 																
<p>9. Lower air outlet louver control</p>	<p>< How to open or close the lower louver at standby mode ></p> <ol style="list-style-type: none"> 1. Push AIR OUTLET SELECT button on the unit operation panel. <p style="text-align: center;">AIR OUTLET SELECT button</p>  <ol style="list-style-type: none"> 2. When lower louver is closed, lower louver moves to open position and TEMPERATURE indicator displays "OP" (OPEN) during louver moving. <p>When lower louver is open, lower louver moves to open position and TEMPERATURE indicator displays "CL" (CLOSE) during louver moving.</p> <p><Close->Open> <Open->Close></p> <p style="text-align: center;">TEMPERATURE indicator</p>  <p>< Louver position in operation ></p> <p>Lower louver is controlled in operation as below.</p> <table border="1" data-bbox="395 1816 900 2069"> <thead> <tr> <th rowspan="2">Louver Position</th> <th colspan="3">Air outlet</th> </tr> <tr> <th>Bi-flow</th> <th>Upper-flow</th> <th>Lower-flow</th> </tr> </thead> <tbody> <tr> <td>OPEN</td> <td></td> <td></td> <td></td> </tr> <tr> <td>CLOSE</td> <td></td> <td></td> <td></td> </tr> </tbody> </table>	Louver Position	Air outlet			Bi-flow	Upper-flow	Lower-flow	OPEN				CLOSE				<ol style="list-style-type: none"> 1. Purpose When something is dropped to inside of the unit from upper air outlet, this function helps to remove something from lower air outlet
Louver Position	Air outlet																
	Bi-flow	Upper-flow	Lower-flow														
OPEN																	
CLOSE																	

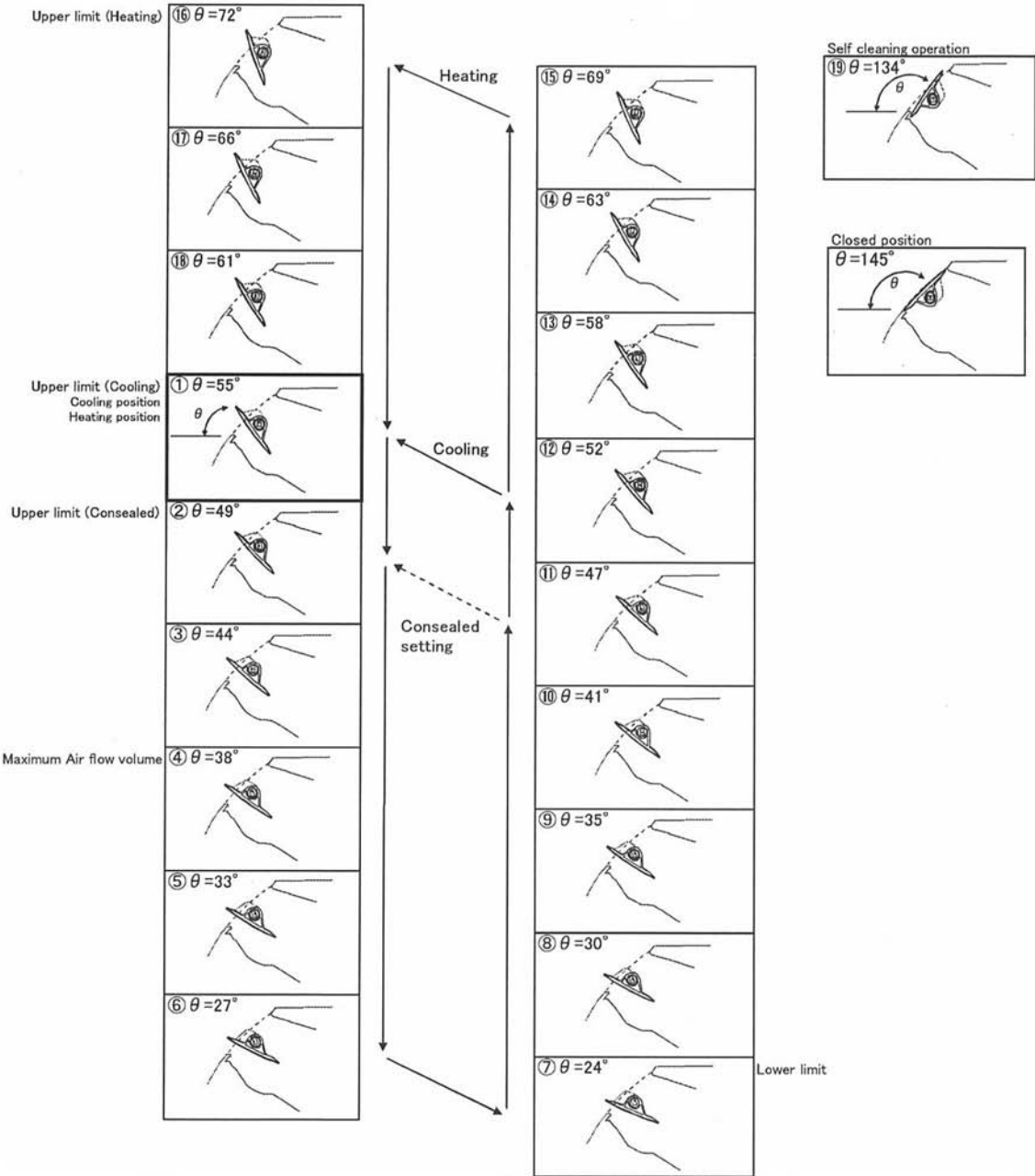
Item	Operation flow and applicable data,etc	Description												
10. Upper air outlet louver control	<p>Upper louver position can be arbitrarily set up by pushing [FIX] button of the remote control.</p> <p>The position is controlled as below.</p> <table border="1" data-bbox="336 524 1465 667"> <thead> <tr> <th>Mode</th> <th>louver position</th> </tr> </thead> <tbody> <tr> <td>Cooling</td> <td>①→②→③→④→⑤→⑥→⑦→⑧→⑨→⑩→⑪→⑫→①.....</td> </tr> <tr> <td>Heating</td> <td>①→②→③→④→⑤→⑥→⑦→⑧→⑨→⑩→⑪→⑫→⑬→⑭→⑮→⑯→⑰→⑱→①...</td> </tr> <tr> <td>Cooling (Consealed setting)</td> <td>②→③→④→⑤→⑥→⑦→⑧→⑨→⑩→⑪→⑫→②.....</td> </tr> <tr> <td>Heating (Consealed setting)</td> <td>②→③→④→⑤→⑥→⑦→⑧→⑨→⑩→⑪→⑫→②.....</td> </tr> <tr> <td>Self cleaning</td> <td>⑱</td> </tr> </tbody> </table>	Mode	louver position	Cooling	①→②→③→④→⑤→⑥→⑦→⑧→⑨→⑩→⑪→⑫→①.....	Heating	①→②→③→④→⑤→⑥→⑦→⑧→⑨→⑩→⑪→⑫→⑬→⑭→⑮→⑯→⑰→⑱→①...	Cooling (Consealed setting)	②→③→④→⑤→⑥→⑦→⑧→⑨→⑩→⑪→⑫→②.....	Heating (Consealed setting)	②→③→④→⑤→⑥→⑦→⑧→⑨→⑩→⑪→⑫→②.....	Self cleaning	⑱	<p>1. Description</p> <ul style="list-style-type: none"> Upper louver position is stored in memory by the microcomputer, and the louver returns to the stored position when the next operation is performed. (Cooling/heating memory position)
Mode	louver position													
Cooling	①→②→③→④→⑤→⑥→⑦→⑧→⑨→⑩→⑪→⑫→①.....													
Heating	①→②→③→④→⑤→⑥→⑦→⑧→⑨→⑩→⑪→⑫→⑬→⑭→⑮→⑯→⑰→⑱→①...													
Cooling (Consealed setting)	②→③→④→⑤→⑥→⑦→⑧→⑨→⑩→⑪→⑫→②.....													
Heating (Consealed setting)	②→③→④→⑤→⑥→⑦→⑧→⑨→⑩→⑪→⑫→②.....													
Self cleaning	⑱													
	 <p>The diagram illustrates the louver control sequence. It shows two columns of louver positions. The left column shows positions for Heating (⑬ to ⑱), Cooling (① to ⑫), and Consealed setting (② to ⑥). The right column shows positions for Heating (⑦ to ⑮), Cooling (⑫ to ⑩), and Consealed setting (⑩ to ④). Arrows indicate the direction of movement: Heating (upward), Cooling (downward), and Consealed setting (upward). Specific limits are marked: Upper limit (Heating) at 72°, Upper limit (Cooling) at 55°, Upper limit (Consealed) at 49°, and Lower limit at 24°. Special operations are shown: Self cleaning operation at 134° and Closed position at 145°.</p>													

Item	Operation flow and applicable data, etc.	Description																								
<p>11. ECO operation</p>	<p>When pressing [ECO] button on the remote controller, a Economic operation is performed.</p> <p><Cooling operation></p> <p>This function operates the air conditioner with the difference between the set and the room temperature as shown in the following figure.</p> <p style="text-align: center;">1H 2H 3H 4H Time</p> <p style="text-align: center;">* 12 (DRY max - COOL min) /6 x 5 + COOL min * 11 (DRY max - COOL min) /6 x 4 + COOL min * 10 (DRY max - COOL min) /6 x 3 + COOL min * 9 (DRY max - COOL min) /6 x 2 + COOL min * 8 (DRY max - COOL min) /6 x 1 + COOL min</p> <table border="1" style="margin-left: auto; margin-right: auto;"> <thead> <tr> <th>Hz</th> <th>B10UFV-E</th> <th>B13UFV-E</th> <th>B18UFV-E</th> </tr> </thead> <tbody> <tr> <td>Cool min</td> <td>20</td> <td>20</td> <td>11</td> </tr> <tr> <td>DRY max</td> <td>35</td> <td>37</td> <td>49</td> </tr> </tbody> </table> <p><Heating operation></p> <p style="text-align: center;">30 minutes → Time Compressor speed</p> <table border="1" style="margin-left: auto; margin-right: auto;"> <thead> <tr> <th>Hz</th> <th>B10UFV-E</th> <th>B13UFV-E</th> <th>B18UFV-E</th> </tr> </thead> <tbody> <tr> <td>a</td> <td>20</td> <td>20</td> <td>15</td> </tr> <tr> <td>c</td> <td>50</td> <td>50</td> <td>68</td> </tr> </tbody> </table>	Hz	B10UFV-E	B13UFV-E	B18UFV-E	Cool min	20	20	11	DRY max	35	37	49	Hz	B10UFV-E	B13UFV-E	B18UFV-E	a	20	20	15	c	50	50	68	<p><Cooling operation></p> <ol style="list-style-type: none"> 1) The control target temperature increase 0.5°C per hour up to 2°C starting from the set temperature when ECONO has been received. 2) The indoor fan speed is depend on presetting and can change every speed after setting ECO operation. 3) The compressor speed is controlled as shown in the left figure. 4) The time correction is performed every 8minutes. <p><Heating operation></p> <ol style="list-style-type: none"> 1) Setting the compressor speed to Max. aHz, the temperature zone in which the operation can be performed with Max. cHz is gradually widened after 30 minutes passed when starting ECO operation. 2) The indoor fan speed is depend on presetting and can change every speed after setting ECO operation.
Hz	B10UFV-E	B13UFV-E	B18UFV-E																							
Cool min	20	20	11																							
DRY max	35	37	49																							
Hz	B10UFV-E	B13UFV-E	B18UFV-E																							
a	20	20	15																							
c	50	50	68																							

Item	Operation flow and applicable data, etc.	Description														
12. Test operation	<p>When keeping [OPERATION] button pressed for 10 seconds or more, the temporary [COOL] operation is performed.</p> <pre> graph TD A[Filter lamp ON] -- NO --> B{Did you press [OPERATION] button for 3 seconds or more?} A -- YES --> C[Press [OPERATION] button.] B -- YES --> C B -- NO --> D[Previous setting operation] C --> E[Test [COOL] Operation] F{Did you press [OPERATION] button for 10 seconds or more?} -- YES --> E F -- NO --> G[Switch to [AUTO RESTART] control.] </pre>	<ol style="list-style-type: none"> 1) When pressing [OPERATION] button, the previous setting operation starts. 2) When keeping [OPERATION] button pressed for 3 seconds or more, Pi, Pi, Pi sound is heard and [AUTO RESTART] control is changed. 3) When keeping [OPERATION] button pressed for 10 seconds or more, "Pi" sound is heard and the test [COOL] operation starts. 4) If the filter lamp goes on, press [OPERATION] button to go off the filter lamp, and then press [OPERATION] button again. 5) To stop the test operation, press the button again. 														
13. Discharge temperature control	<table border="1" data-bbox="165 860 922 1196"> <thead> <tr> <th data-bbox="165 860 320 898">Td value</th> <th data-bbox="320 860 922 898">Control operation</th> </tr> </thead> <tbody> <tr> <td data-bbox="165 898 320 936">117°C</td> <td data-bbox="320 898 922 936">Judges as an error and stops the compressor.</td> </tr> <tr> <td data-bbox="165 936 320 974">112°C</td> <td data-bbox="320 936 922 974">Reduce the compressor speed.</td> </tr> <tr> <td data-bbox="165 974 320 1012">108°C</td> <td data-bbox="320 974 922 1012">Reduce slowly compressor speed.</td> </tr> <tr> <td data-bbox="165 1012 320 1050">105°C</td> <td data-bbox="320 1012 922 1050">Keeps the compressor speed.</td> </tr> <tr> <td data-bbox="165 1050 320 1149">98°C</td> <td data-bbox="320 1050 922 1149">If the operation is performed with lower speed than one commanded by the serial signal, speed is slowly raised up to the commanded speed.</td> </tr> <tr> <td data-bbox="165 1149 320 1196">98°C</td> <td data-bbox="320 1149 922 1196">Operates with speed commanded by the serial signal.</td> </tr> </tbody> </table>	Td value	Control operation	117°C	Judges as an error and stops the compressor.	112°C	Reduce the compressor speed.	108°C	Reduce slowly compressor speed.	105°C	Keeps the compressor speed.	98°C	If the operation is performed with lower speed than one commanded by the serial signal, speed is slowly raised up to the commanded speed.	98°C	Operates with speed commanded by the serial signal.	<ol style="list-style-type: none"> 1. Purpose This function detects error on the refrigerating cycle or error on the compressor, and performs protective control. 2. Operation <ul style="list-style-type: none"> • Control of the compressor speed The speed control is performed as described in the left table based upon the discharge temperature.
Td value	Control operation															
117°C	Judges as an error and stops the compressor.															
112°C	Reduce the compressor speed.															
108°C	Reduce slowly compressor speed.															
105°C	Keeps the compressor speed.															
98°C	If the operation is performed with lower speed than one commanded by the serial signal, speed is slowly raised up to the commanded speed.															
98°C	Operates with speed commanded by the serial signal.															

Item	Operation flow and applicable data, etc.	Description
<p>14. Pulse Modulating value (P.M.V.) control</p>	<p>This function controls throttle amount of the refrigerant in the refrigerating cycle. According to operating status of the air conditioner, this function also controls the open degree of valve with an expansion valve with pulse Modulation.</p> <pre> graph TD Start[Starting up] --> Init[Initialize] Init --> Move[Move to initial position] Move --> Comp[Compressor ON] Comp --> SH[*SH control] Comp --> Td[Td release control] SH --> PMV[*PMV open degree control] Td --> PMV PMV --> Remote[Stop by remote controller] PMV --> Room[Room temp. sensor (Ta sensor) control] Remote --> Power[Power OFF] Room --> Defrost[Defrost] Defrost --> Move </pre> <p>* SH (Super Heat amount) = TS (Temperature of suction pipe of the compressor) – TC or TE (Heat exchanger temperature at evaporation side)</p> <p>* PMV: Pulse Modulating Valve</p>	<ol style="list-style-type: none"> 1) When starting the operation, move the valve once until it fits to the stopper. (Initialize) In this time, "Click" sound may be heard. 2) Adjust the open degree of valve by super heat amount. (SH control) 3) If the discharge temperature was excessively up, adjust the open degree of valve so that it is in the range of set temperature. (Discharge temp. control) 4) When defrost operation is performed, the open degree of valve is adjusted according to each setup conditions during preparation for defrost and during defrost operation (4-way valve is inversed.). 5) To turn off the compressor while the air conditioner stops by control of the thermostat or by remote controller, adjust the open degree of valve to the setup value before stop of the compressor.

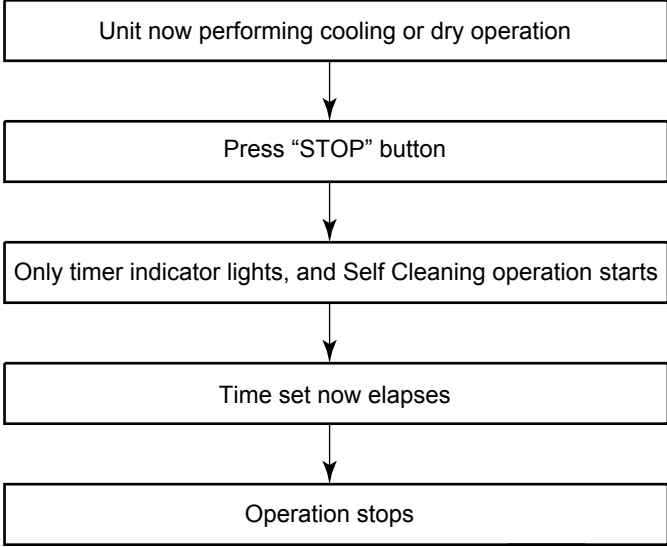
Item	Operation flow and applicable data, etc.	Description													
<p>15. Self-Cleaning function</p>	 <pre> graph TD A[Unit now performing cooling or dry operation] --> B[Press "STOP" button] B --> C[Only timer indicator lights, and Self-Cleaning operation starts] C --> D[Time set now elapses] D --> E[Operation stops] </pre> <ul style="list-style-type: none"> • During Self-Cleaning operations: The louver opens slightly. The indoor fan operates continuously at a speed of 240 rpm. <p>Self-Cleaning operation times</p> <table border="1" data-bbox="397 1227 1262 1576"> <thead> <tr> <th></th> <th>Operation time</th> <th>Self-Cleaning operation time</th> </tr> </thead> <tbody> <tr> <td rowspan="2">Cooling: Auto (cooling) Dry</td> <td>Up to 10 minutes</td> <td>No Self-Cleaning operation performed (0 minutes)</td> </tr> <tr> <td>10 minutes or longer</td> <td>30 mins.</td> </tr> <tr> <td>Heating: Auto (heating)</td> <td colspan="2" rowspan="3">No Self-Cleaning operation performed</td> </tr> <tr> <td>Auto (fan only)</td> </tr> <tr> <td>Shutdown</td> </tr> </tbody> </table> <ul style="list-style-type: none"> • To stop an ongoing Self-Cleaning operation at any time Press the start/stop button on the remote controller twice during the Self-Cleaning operation. (After pressing the button for the first time, press it for the second time without delay (within 10 minutes).) 		Operation time	Self-Cleaning operation time	Cooling: Auto (cooling) Dry	Up to 10 minutes	No Self-Cleaning operation performed (0 minutes)	10 minutes or longer	30 mins.	Heating: Auto (heating)	No Self-Cleaning operation performed		Auto (fan only)	Shutdown	<p>1. Purpose</p> <p>The Self-Cleaning operation is to minimize the growth of mold, bacteria etc. by running the fan and drying so as to keep the inside of the air conditioner clean.</p> <p>Self-Cleaning operation</p> <p>When the cooling or dry operation shuts down, the unit automatically starts the Self-Cleaning operation which is then performed for the specified period based on duration of the operation which was performed prior to the shutdown, after which the Self-Cleaning operation stops. (The Self-Cleaning operation is not performed after a heating operation.)</p> <p>2. Operation</p> <ol style="list-style-type: none"> 1) When the stop signal from the remote controller or timer-off function is received, only the timer indicator light. 2) The period of the Self-Cleaning operation is determined by the duration of the operation performed prior to the reception of the stop code. 3) After the Self-Cleaning operation has been performed for the specified period, the unit stops operating.
	Operation time	Self-Cleaning operation time													
Cooling: Auto (cooling) Dry	Up to 10 minutes	No Self-Cleaning operation performed (0 minutes)													
	10 minutes or longer	30 mins.													
Heating: Auto (heating)	No Self-Cleaning operation performed														
Auto (fan only)															
Shutdown															

Item	Operation flow and applicable data, etc.	Description																													
15. Self-Cleaning function	<ul style="list-style-type: none"> Self-Cleaning diagram 	<table border="1" data-bbox="156 271 1433 719"> <thead> <tr> <th data-bbox="156 271 336 315">Operation display</th> <th data-bbox="336 271 775 315">ON</th> <th data-bbox="775 271 1054 315">OFF</th> <th data-bbox="1054 271 1433 315">OFF</th> </tr> </thead> <tbody> <tr> <td data-bbox="156 315 336 387">FCU fan</td> <td data-bbox="336 315 775 387">ON rpm is depend on presetting.</td> <td data-bbox="775 315 1054 387">ON (240RPM)</td> <td data-bbox="1054 315 1433 387">OFF</td> </tr> <tr> <td data-bbox="156 387 336 432">Upper airoutlet</td> <td data-bbox="336 387 775 432">OPEN</td> <td data-bbox="775 387 1054 432">OPEN (11°)</td> <td data-bbox="1054 387 1433 432">CLOSE</td> </tr> <tr> <td data-bbox="156 432 336 504">Lower airoutlet</td> <td data-bbox="336 432 775 504">OPEN or CLOSE depend on airoutlet selection</td> <td data-bbox="775 432 1054 504">OPEN or CLOSE depend on airoutlet selection</td> <td data-bbox="1054 432 1433 504">OPEN or CLOSE depend on airoutlet selection</td> </tr> <tr> <td data-bbox="156 504 336 575">Timer display</td> <td data-bbox="336 504 775 575">ON or OFF depend on presetting of timer function.</td> <td data-bbox="775 504 1054 575">ON</td> <td data-bbox="1054 504 1433 575">ON or OFF depend on presetting of timer function.</td> </tr> <tr> <td data-bbox="156 575 336 647">Compressor</td> <td data-bbox="336 575 775 647">ON or OFF depend on presetting per room temperature.</td> <td data-bbox="775 575 1054 647">OFF</td> <td data-bbox="1054 575 1433 647">OFF</td> </tr> <tr> <td data-bbox="156 647 336 719">CDU fan</td> <td data-bbox="336 647 775 719">ON or OFF depend on presetting per room temperature.</td> <td data-bbox="775 647 1054 719">OFF</td> <td data-bbox="1054 647 1433 719">OFF</td> </tr> </tbody> </table> <div data-bbox="336 719 1433 907" style="text-align: center;"> <p style="text-align: center;">Turn off by remote controller or timer-off function. Automatically turn-off.</p> </div>		Operation display	ON	OFF	OFF	FCU fan	ON rpm is depend on presetting.	ON (240RPM)	OFF	Upper airoutlet	OPEN	OPEN (11°)	CLOSE	Lower airoutlet	OPEN or CLOSE depend on airoutlet selection	OPEN or CLOSE depend on airoutlet selection	OPEN or CLOSE depend on airoutlet selection	Timer display	ON or OFF depend on presetting of timer function.	ON	ON or OFF depend on presetting of timer function.	Compressor	ON or OFF depend on presetting per room temperature.	OFF	OFF	CDU fan	ON or OFF depend on presetting per room temperature.	OFF	OFF
Operation display	ON	OFF	OFF																												
FCU fan	ON rpm is depend on presetting.	ON (240RPM)	OFF																												
Upper airoutlet	OPEN	OPEN (11°)	CLOSE																												
Lower airoutlet	OPEN or CLOSE depend on airoutlet selection	OPEN or CLOSE depend on airoutlet selection	OPEN or CLOSE depend on airoutlet selection																												
Timer display	ON or OFF depend on presetting of timer function.	ON	ON or OFF depend on presetting of timer function.																												
Compressor	ON or OFF depend on presetting per room temperature.	OFF	OFF																												
CDU fan	ON or OFF depend on presetting per room temperature.	OFF	OFF																												
16. Self-Cleaning function release	<p>How to cancel Self-Cleaning function</p> <p>To cancel the Self-Cleaning function, proceed as follows:</p> <p>Press and hold [MODE] button on operation panel for more than 10 seconds. (less than 20 seconds)</p> <p>After holding about 10 seconds, the air conditioner beep 4 times without any blinking of display.</p> <p>After releasing [Mode] button, Self-Cleaning function is cancelled.</p> <p>How to set Self-Cleaning function</p> <p>To set the Self-Cleaning function, proceed as follows:</p> <p>Press and hold [MODE] button on operation panel for more than 10 seconds. (less than 20 seconds)</p> <p>After holding about 10 seconds, the air conditioner beep 4 times and OPERATION display blinks 5 seconds.</p> <p>After releasing [Mode] button, Self-Cleaning function is set.</p>																														

Item	Operation flow and applicable data, etc.	Description
<p>17. Remote-A or B selection</p>	<p>To separate using of remote control for each indoor unit in case of 2 air conditioner are installed nearby.</p> <p>Remote Control B Setup.</p> <ol style="list-style-type: none"> 1) Press RESET button on the indoor unit to turn the air conditioner ON. 2) Point the remote control at the indoor unit. 3) Push and hold CHK ● button on the Remote Control by the tip of the pencil. "00" will be shown shown on the display. 4) Press MODE ● during pushing CHK ●. "B" will show on the display and "00" will disappear and the air conditioner will turn OFF. The Remote Control B is memorized. <p>Note : 1. Repeat above step to reset Remote Control to be A. 2. Remote Control A has not "A" display. 3. Default setting of Remote Control from factory is A.</p> <div data-bbox="432 913 887 1099" style="text-align: center;"> </div> <p>Indoor Unit B Setup.</p> <ol style="list-style-type: none"> 1) Press and hold [Mode] button for more than 20 seconds. 2) After holding 20 seconds, the air conditioner beep 5 times, without any blinking of display. 3) After releasing [Mode] button, Indoor Unit B is set. <p>Note :</p> <ol style="list-style-type: none"> 1. After holding 10 seconds, the air conditioner beep 4 times, but continue to hold [Mode] button. 2. Repeat above step to reset Indoor Unit A. After holding 20 seconds, the airconditioner beep 5 times and operation display blinks for 5 seconds. 	<ol style="list-style-type: none"> 1. Purpose This operation is to operate only one indoor unit using one remote controller. 2. Description When operating one indoor unit in a situation where two indoor units have been installed in the same room or nearby rooms, this operation prevents the remote controll signal from being received simultaneously by both units, thus preventing both units from operating. 3. Operation The indoor unit on which the remote controll selection has been set to B receives the signal of the remote control also set to B. (At the factory the remote controller selection is set to A on all the indoor units. There is no A setting display.)

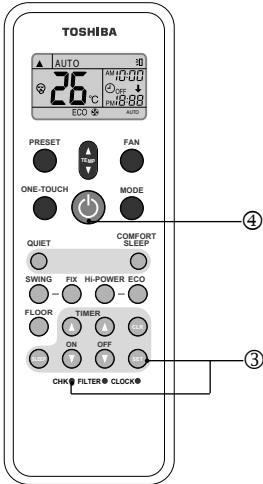
Item	Operation flow and applicable data, etc.	Description
18. QUIET mode	When the [QUIET] button is pressed, the fan of the indoor unit will be restricted the revolving speed at speed L – until the [QUIET] button is pressed once again (cancel Quiet mode).	Quiet mode is the system which, control the revolving speed of indoor fan to work constantly at lower than speed L. In addition, noise level of indoor unit is less than usual. Remarks : 1. Quiet mode is unable to work in dry mode. 2. Quiet mode is appropriate to work with less cooling load and less heating load condition. Because of the fan speed L- may cause not enough the cooling capacity or heating capacity.
19. COMFORT SLEEP	<p>Cooling mode</p> <ul style="list-style-type: none"> The preset temperature will increase as show on ECO operation (Item No. 9) Press the [COMFORT SLEEP] button to choose the operating hours. Repeat pressing to select the hours. (1hr, 3hr, 5hr or 9hr) If the [COMFORT SLEEP] button is pressed again means cancel comfort sleep mode. <p>Heating mode</p> <ul style="list-style-type: none"> The preset temperature will drop down as show on ECO operation (Item No. 9) Press the [COMFORT SLEEP] button to choose the operating hours. Repeat pressing to select the hours. (1hr, 3hr, 5hr or 9 hr) If the [COMFORT SLEEP] button is pressed again means cancel comfort sleep mode. 	The principles of comfort sleep mode are: <ul style="list-style-type: none"> Quietness for more comfortable. When room temperature reach setting temperature Save energy by changing room temperature automatically. The air condition can shut down by itself automatically. Remarks: 1. Comfort sleep mode will not operate in dry mode.
20. Short Timer	In the normal condition, after switching one circuit breaker, 3-minute delay time for compressor and 1 hour for plasma air purifier are set for the maintenance of the unit. 	<p>Purpose</p> To start the unit immediately for the purpose of testing, trial...etc, short timer can be used. maintenance of the unit. <p>Short Timer Setting</p> <ol style="list-style-type: none"> Press [⏻] button to turn the unit OFF. Set the operation mode on the remote control without sending the signal to the unit. Use the tip of the pencil to push the [CHK] button and hold, "00" will show on display, then press [SET] button to make "00" disappear. Press [⏻] button to turn the unit ON. When short timer is activated, all setting on the remote operates immediately, besides, all indications on front panel turns ON continuously for 3 seconds.

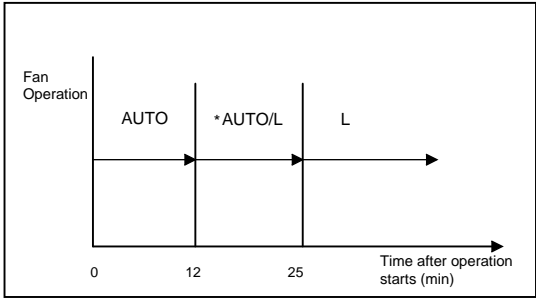
Item	Operation flow and applicable data, etc.	Description
<p>21. One-Touch Comfort</p>	<p>One touch comfort is the fully automated operation that is set according to the preferable condition in a region.</p>  <p>*AUTO/L: Fan operates depends on the setting temperature and room temperature.</p> <p>During the One Touch Comfort mode if the indoor unit receives any signal with other operation mode, the unit will cancel the comfort mode and operates according to the signal received.</p>	<p>Operation condition for model to Europe market</p> <p>When an indoor unit receives "One Touch Comfort Signal" from the remote controller, the indoor unit operates as following.</p> <ol style="list-style-type: none"> 1) Air conditioner starts to operation when the signal is received, even if the air conditioner was OFF. 2) Operation mode is set according to room temperature, the same as AUTO mode. 3) Target temperature is 24°C. 4) Louver position is set as stored position of the operating mode. 5) Fan is controlled as followings.
<p>22. Hi-POWER Mode</p>	<p>([Hi-POWER] button on the remote controller is pressed)</p> <p>When [Hi-POWER] button is pressed while the indoor unit is in Auto, Cooling or Heating operation, Hi-POWER mark is indicated on the display of the remote controller and the unit operates as follows.</p> <ol style="list-style-type: none"> 1. Automatic operation <ul style="list-style-type: none"> • The indoor unit operates in according to the current operation. 2. Cooling operation <ul style="list-style-type: none"> • The preset temperature drops 1°C (The value of the preset temperature on the remote controller does not change.) The indoor unit's fan speed level increase 1 tap 3. Heating operation <ul style="list-style-type: none"> • The preset temperature increases 2°C (The value of the preset temperature on the remote controller does not change.) The indoor unit's fan speed level increase 1 tap 4. The Hi-POWER mode can not be set in Dry operation 	
<p>23. FILTER Indicator</p>	<p>When the elapsed time reaches 1000 hours after operation, the FILTER indicator lights. After cleaning the filters, turn off the FILTER indicator.</p> <p>How to Turn Off FILTER Indicator Press [OPERATION] button on the indoor unit.</p>	

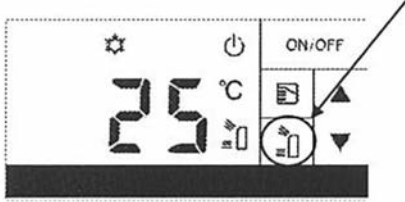
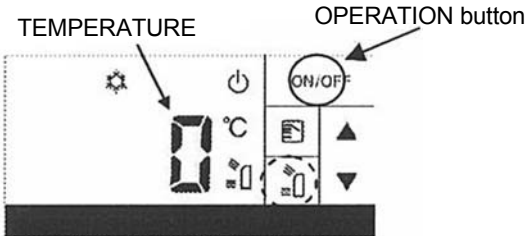
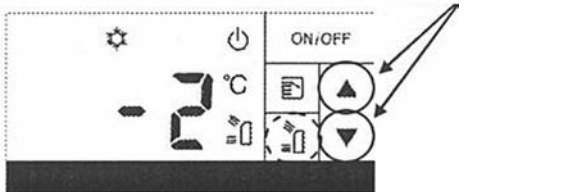
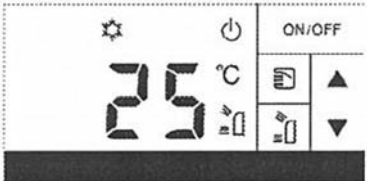
Item	Operation flow and applicable data,etc	Description						
<p>24. Set temp. correction</p>	<p>Set temp. can be corrected by changing the set temp. correction value. Initial setting of the set temp. correction value is 0.</p> <p>Set temp. = Set temp. (TS)+ Set temp. correction Set temp. (TS) : remote control or indoor unit display setting</p> <table border="1" data-bbox="359 392 890 537"> <thead> <tr> <th></th> <th>Set temp. correction</th> </tr> </thead> <tbody> <tr> <td>Cooling (Dry mode)</td> <td>-5 ~ +5°C</td> </tr> <tr> <td>Heating</td> <td>-5 ~ +5°C</td> </tr> </tbody> </table> <p>< How to change the set temp. correction ></p> <ol style="list-style-type: none"> Operate the air conditioner and select cooling or heating mode. (The set temp. correction can't be changed at standby mode.) Push and hold AIR OUTLET SELECT button on the unit operation panel <p style="text-align: center;">AIR OUTLET SELECT button</p>  <ol style="list-style-type: none"> Push OPERATION button on the unit operation panel 10 times. Set temp. correction value is displayed on the TEMPERATURE indicator. <p style="text-align: center;">TEMPERATURE OPERATION button</p>  <ol style="list-style-type: none"> Push TEMPERATURE button (UP or DOWN) to change set temp. correction. <p style="text-align: center;">TEMPERATURE button</p>  <ol style="list-style-type: none"> Release AIR OUTLET SELECT button. Set temp. correction is memorized and set temp. value is displayed on the TEMPERATURE indicator again. 		Set temp. correction	Cooling (Dry mode)	-5 ~ +5°C	Heating	-5 ~ +5°C	<ol style="list-style-type: none"> Purpose When the difference between the set temperature of the remote control and the room temperature is wide due to the installation condition, etc, the set temperature can be corrected. Description For example, when set temp. is 25°C but room temp. is stable 27°C at cooling mode, change set temp. correction (Cooling) from 0 to -2°C <ul style="list-style-type: none"> Continue to push and hold AIR OUTLET SELECT button. Continue to push and hold AIR OUTLET SELECT button.
	Set temp. correction							
Cooling (Dry mode)	-5 ~ +5°C							
Heating	-5 ~ +5°C							

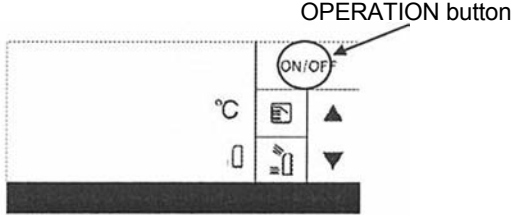
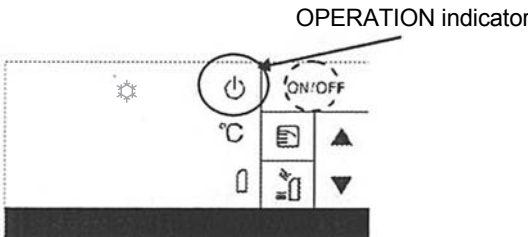
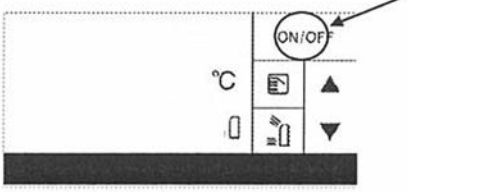
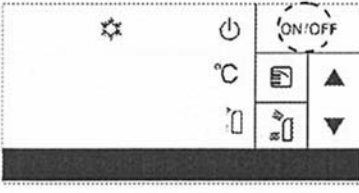
Item	Operation flow and applicable data,etc	Description																											
<p>25. Outdoor Quiet control (for only 1:1 outdoor unit)</p>	<p>As shown in the table, the max. revolution number of compressor can be reduced. As the max. number of revolution of compressor is restricted, the rise-up performance at the start time is weakened. This function is disable with multi-outdoor unit connecting.</p> <table border="1" data-bbox="343 392 981 537"> <thead> <tr> <th rowspan="2">MODE</th> <th colspan="2">RAS-B10UFV-E</th> <th colspan="2">RAS-B13UFV-E</th> <th colspan="2">RAS-B18UFV-E</th> </tr> <tr> <th>Normal (rps)</th> <th>Normal (rps)</th> <th>Normal (rps)</th> <th>Normal (rps)</th> <th>Normal (rps)</th> <th>Normal (rps)</th> </tr> </thead> <tbody> <tr> <td>Cooling</td> <td>62</td> <td>53</td> <td>94</td> <td>77</td> <td>85</td> <td>72</td> </tr> <tr> <td>Heating</td> <td>86</td> <td>73</td> <td>99</td> <td>76</td> <td>85</td> <td>72</td> </tr> </tbody> </table> <p>When air conditioner is on standby before setting. < How to set Outdoor Quiet control ></p> <ol style="list-style-type: none"> Push and hold OPERATION button for 20seconds.  <ol style="list-style-type: none"> After holding 20seconds, beep sounds is heard and OPERATION indicator flashes for 5seconds. Release OPERATION button.  <ol style="list-style-type: none"> Push OPERATION button to stop temporary operation. (Set Auto restart function again) <p>< How to cancel Outdoor Quiet control ></p> <ol style="list-style-type: none"> Push and hold OPERATION button for 20seconds.  <ol style="list-style-type: none"> After holding 20seconds, beep sounds is heard. (OPERATION indicator doesn't flash). Release OPERATION button.  <ol style="list-style-type: none"> Push OPERATION button to stop temporary operation. (Set Auto restart function again) 	MODE	RAS-B10UFV-E		RAS-B13UFV-E		RAS-B18UFV-E		Normal (rps)	Normal (rps)	Normal (rps)	Normal (rps)	Normal (rps)	Normal (rps)	Cooling	62	53	94	77	85	72	Heating	86	73	99	76	85	72	<ol style="list-style-type: none"> Purpose For the users who concern about noise of the outdoor unit, this control controls the max. revolution number of the compressor to reduce the noise. Description <ul style="list-style-type: none"> It can be change setting whether air conditioner is operating or not. After pushing OPERATION button, air conditioner starts operation. After 3seconds, 3 beeps are heard. (Auto restart setting is changed.) After 10seconds, a beep is heard. (Temporary operation starts and Auto restart function is cancelled.)
MODE	RAS-B10UFV-E		RAS-B13UFV-E		RAS-B18UFV-E																								
	Normal (rps)	Normal (rps)	Normal (rps)	Normal (rps)	Normal (rps)	Normal (rps)																							
Cooling	62	53	94	77	85	72																							
Heating	86	73	99	76	85	72																							

9-3. Auto Restart Function

This indoor unit is equipped with an automatic restarting function which allows the unit to restart operating with the set operating conditions in the event of a power supply being accidentally shut down.

The operation will resume without warning three minutes after power is restored.

This function is not set to work when shipped from the factory. Therefore it is necessary to set it to work.

9-3-1. How to Set the Auto Restart Function

To set the auto restart function, proceed as follows:

The power supply to the unit must be on ; the function will not set if the power is off.

Press the [OPERATION] button located in the display of the indoor unit continuously for three seconds.

The unit receives the signal and beeps three times.

The unit then restarts operating automatically in the event of power supply being accidentally shut down.

• When the unit is standby (Not operating)

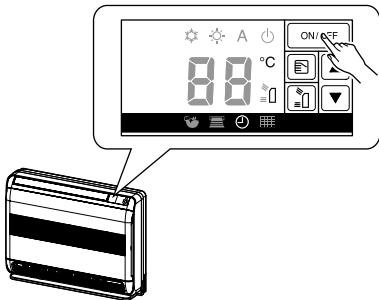
Operation	Motions
<p>Press [OPERATION] button for more than three seconds. (Less than 10 seconds)</p> 	<p>The unit is on standby.</p> <p>The unit starts to operate. The operation indicator is on.</p> <p>After approx. three seconds,</p> <p>The unit beeps three times and continues to operate. The operation indicator flashes for 5 seconds.</p> <p>If the unit is not required to operate at this time, press [OPERATION] button once more or use the remote control to turn it off.</p>

• When the unit is in operation

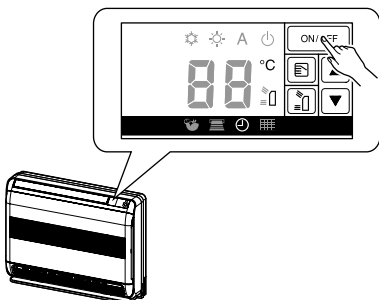
Operation	Motions
<p>Press [OPERATION] button for more than three seconds. (Less than 10 seconds)</p> 	<p>The unit is in operation. The operation indicator is on.</p> <p>The unit stops operating. The operation indicator is turned off.</p> <p>After approx. three seconds,</p> <p>The unit beeps three times. The operation indicator flashes for 5 seconds.</p> <p>If the unit is required to operate at this time, press [OPERATION] button once more or use the remote control to turn it on.</p>

- While the filter check indicator is on, OPERATION button has the function of filter reset button.

9-3-2. How to Cancel the Auto Restart Function

To cancel auto restart function, proceed as follows :

Repeat the setting procedure : the unit receives the signal and beeps three times.

The unit will be required to be turned on with the remote control after the main power supply is turned off.

• When the system is on stand-by (not operating)

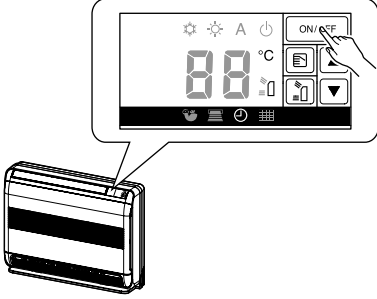
Operation	Motions
<p>Press [OPERATION] button for more than three seconds. (Less than 10 seconds)</p> 	<p>The unit is on standby.</p> <p>The unit starts to operate. The operation indicator is on.</p> <p>After approx. three seconds,</p> <p>The unit beeps three times and continues to operate.</p> <p>If the unit is not required to operate at this time, press [OPERATION] button once more or use the remote control to turn it off.</p>

• When the system is operating

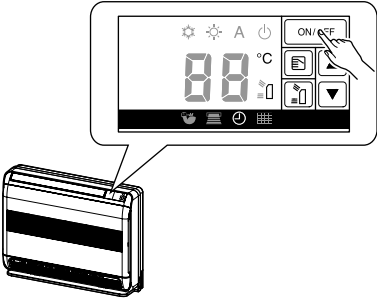
Operation	Motions
<p>Press [OPERATION] button for more than three seconds. (Less than 10 seconds)</p> 	<p>The unit is in operation. The operation indicator is on.</p> <p>The unit stops operating. The operation indicator is turned off.</p> <p>After approx. three seconds,</p> <p>The unit beeps three times.</p> <p>If the unit is required to operate at this time, press [OPERATION] button once more or use the remote control to turn it on.</p>

9-3-3. Power Failure During Timer Operation

When the unit is turned off because of power failure during timer operation, the timer operation is cancelled. In that case, set the timer operation again.

NOTE :

The Everyday Timer is reset while a command signal can be received from the remote control even if it stopped due to a power failure.

9-4. Remote control

9-4-1. Remote control and its functions

- ① Infrared signal emitter
- ② Start/Stop button
- ③ Mode select button (MODE)
- ④ Temperature button (TEMP)
- ⑤ Fan speed button (FAN)
- ⑥ Swing louver button (SWING)
- ⑦ Set louver button (FIX)
- ⑧ On timer button (ON)
- ⑨ Off timer button (OFF)
- ⑩ Sleep timer button (SLEEP)
- ⑪ Setup button (SET)
- ⑫ Clear button (CLR)
- ⑬ Memory and Preset button (PRESET)
- ⑭ One Touch button (ONE-TOUCH)
- ⑮ High power button (Hi-POWER)
- ⑯ Economy button (ECO)
- ⑰ Quiet button (QUIET)
- ⑱ Comfort sleep button (COMFORT SLEEP)
- ⑲ Filter reset button (FILTER)
- ⑳ Clock Reset button (CLOCK)
- ㉑ Check button (CHK)
- ㉒ Floor warming mode button (FLOOR)

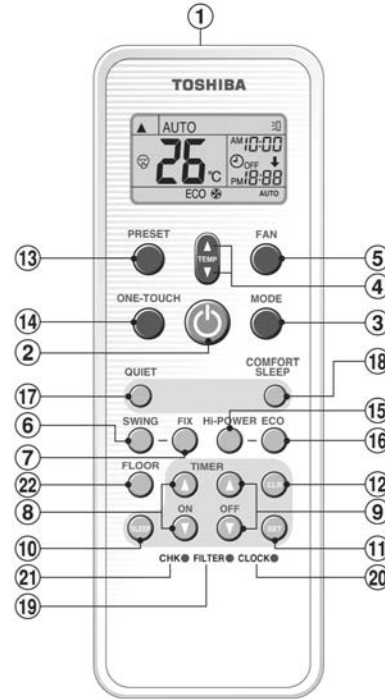

9-4-2. Operation of remote control

1. ONE-TOUCH

Press the "ONE-TOUCH" button for fully automated operation that is customised to the typical consumer preferences in your region of the world. The customised settings control temperature air flow strength, air flow direction and other settings to provide you alternate contact with "ONE-TOUCH" of the button. If you prefer other settings you can select from the many other operation functions of your Toshiba unit









Press ● ONE-TOUCH : Start the operation.

2. AUTOMATIC OPERATION

To automatically select cooling, heating operation.



1. Press ● MODE : Select A.
2. Press  MODE : Select A.

3. COOLING / HEATING OPERATION

1. Press ● MODE : Select Cool  or Heat .
2. Press  MODE : Set the desired temperature.
Cooling: Min. 17°C, Heating : Max. 30°C.
3. Press ● FAN : Select AUTO, LOW , LOW+ , MED , MED+ , or HIGH .

4. DRY OPERATION (COOLING ONLY)

For dehumidification, a moderate cooling performance is controlled automatically.

1. Press  MODE : Select Dry .
2. Press  MODE : Set the desired temperature.

5. HI-POWER OPERATION

To automatically control room temperature and airflow for faster cooling or heating operation (except in DRY and FAN ONLY mode)

Press  HI-POWER : Start and stop the operation.

6. FLOOR WARMING OPERATION

Heating will operate with downward blowing only.
Temperature of air outlet will be higher than usual.

7. ECO OPERATION

To automatically control room to save energy (except in DRY and FAN ONLY mode)

Press  ECO : Start and stop the operation.







Note: Cooling operation; the set temperature will increase automatically 1 degree/hour for 2 hours (maximum 2 degrees increase). For heating operation the set temperature will decrease.

8. TEMPORARY OPERATION

In case of the misplaced or discharged remote control





- Pressing the RESET button, the unit can start or stop without using the remote control.
- Operation mode is set on AUTOMATIC operation, preset temperature is 24°C and fan operation is automatic speed.

9. TIMER OPERATION

Setting the ON Timer		Setting the OFF Timer	
1	Press  : Set the desired ON timer.	Press  : Set the desired OFF timer.	
2	Press  : Set the timer	Press  : Set the timer.	
3	Press  : Cancel the timer	Press  : Cancel the timer.	

Everyday timer allows the user to set both the ON & OFF timers and will be activated on a daily basis.

Setting Everyday Timer

1	Press  : Set the ON timer.	3	Press  .
2	Press  : Set the OFF timer.	4	Press  button during the (↑ or ↓) mark flashing.

- During the every day timer is activation, both arrows (↑ or ↓) are indicated.

Note:

- Keep the remote control in accessible transmission to the indoor unit; otherwise, the time lag of up to 15 minutes will occur.
- The setting will be saved for the next same operation.

10. PRESET OPERATION

Set your preferred operation for future use. The setting will be memorized by the unit for future operation (except air flow direction).

1. Select your preferred operation.
2. Press and hold ● PRESET for 3 seconds to memorize the setting. The ● mark displays.
3. Press ● PRESET : Operate the preset operation.

11. AUTO RESTART OPERATION

To automatically restart the conditioner after the power failure (Power of the unit must be on.)

Setting

1. Press and hold the RESET button on the indoor unit for 3 seconds to set the operation. (3 beep sound and OPERATION lamp blink 5 time/sec for 5 secpmds)
 - Do not operate ON timer and OFF timer.
2. Press and hold the RESET button on the indoor unit for 3 seconds to cancel the operation. (3 beep sound but OPERATION lamp does not blink)

12. QUIET OPERATION

To operate at super low fan speed for quiet operation (except in DRY mode)

Press ● QUIET : Start and stop the operation.

Note: Under certain conditions, QUIET operation may not provide adequate cooling or heating due to low sound features.

13. COMFORT SLEEP OPERATION

To save energy while sleeping, automatically control air flow and automatically turn OFF.

Press ● COMFORT SLEEP : Select 1, 3, 5 or 9 hrs for OFF timer operation.

Note: The cooling operation, the set temperature will increase automatically 1 degree/hour for 2 hours (maximum 2 degrees increase). For heating operation, the set temperature will decrease.

14. SLEEP TIMER OPERATION

To start the sleep timer (OFF timer) operation

Press ● SLEEP : Select 1, 3, 5 or 9 hrs for OFF timer operation.

Press ● CLR to cancel the sleep timer operation.

15. FILTER RESET

⚠ Firstly, turn off the circuit breaker.

FILTER lamp lights on; the filter must be cleaned.

To turn off the lamp, push OPERATION button on the indoor unit or the FILTER button on the remote control.

Note: The filter indicator turns on after turns on after about 1000 hours.

Indoor Unit and Remote Control

- Clean the indoor unit and the remote control with a wet cloth when needed.
- No benzine, thinner, polishing powder or chemically-treated duster.

16. SELF CLEANING OPERATION (COOL AND DRY OPERATION ONLY)

Cleaning operation

This function is used to dry the inside of the air conditioner to reduce the growth of mold, etc. inside the air conditioner.

- When the unit shuts down after having operated for 10 or more minutes in the cooling or dry mode, the cleaning operation is started automatically, and the TIMER indicator on the unit's display panel turns on.

Cleaning operation duration

- The cleaning operation lasts for 30 minutes if the unit has been operating in the cooling or dry mode for 10 minutes or more.

Note:

- SELF CLEANING operation is default setting from factory.
- How to cancel SELF CLEANING operation.
Press and hold MODE button on operation panel for more than 10 seconds (less than 20 seconds). When canceling, 4 beeps sound.
- How to activate SELF CLEANING operation.
Press and hold MODE button on operation panel for more than 10 seconds (less than 20 seconds). Then, 4 beeps will sound and operation lamp will blink for 5 seconds.

17. OPERATION AND PERFORMANCE

1. Three-minute protection feature: To prevent the unit from being activated for 3 minutes when suddenly restarted or switched to ON.
2. Preheating operation: Warm up the unit for 5 minutes before blowing warm air.
3. Warm air control: When the room temperature reaches the set temperature, the fan speed is automatically reduced and the outdoor unit will stop.
4. Automatic defrosting: Fans will stop during defrost operation.
5. Heating capacity: heat is absorbed from outdoor and released into the room.
When the outdoor temperature is too low, use another recommended heating apparatus in combination with the air conditioner.
6. Consideration for accumulated snow: Select the position for outdoor unit when it will not be subjected to snow drifts, accumulation of leaves or other seasonal debris.
7. Some minor cracking sound may occur when unit operating. This is normal because the cracking sound may be caused by expansion/contraction of plastic.

Operation \ Temp.	Outdoor Temperature	Room Temperature
	RAS-10, 13,18SAV Series	
Heating	-15°C ~ 24°C	Less than 28°C
Cooling	-10°C ~ 46°C	21°C ~ 32°C
Dry	-10°C ~ 46°C	21°C ~ 32°C

* Concerning multiple connections, please inquire to the dealership or refer to the catalog.

18. TROUBLESHOOTING (CHECK POINT)

The unit does not operate.	Cooling or Heating is abnormally low
<ul style="list-style-type: none"> • The power main switch is turned off. • The circuit breaker is activated to cut off the power supply. • Stoppage of electric current. • ON timer is set. 	<ul style="list-style-type: none"> • The filters are blocked with dust. • The temperature has been set improperly. • The windows or doors are opened. • The air inlet or outlet of the outdoor unit is blocked. • The fan speed is too low. • The operation mode is DRY.

Note: When there is an abnormality in the product, abnormal code (2 digits) will be displayed on the unit display panel. Please contact the dealership.

In case of multiple connection

- Check whether the operation mode is different from what has been selected for the units in the other rooms (The following combinations of operations cannot be performed: COOL and HEAT, DRY and HEAT).
- Select the same operation mode as for the other rooms.

19. REMOTE CONTROL A-B SELECTION

To separate using of remote control for each indoor unit in case of 2 air conditioners are installed nearby.

Remote Control B Setup.

1. Push and hold CHK · button on the Remote Control by the tip of the pencil.
"00" will be shown on the display.
2. Press ● MODE : during pushing CHK ·. "B" will show on the display and "00" will disappear and the air conditioner will turn OFF. The Remote Control B is memorized.

- Note:**
1. Repeat above step to reset Remote Control to be A.
 2. Remote Control A has not "A" display.
 3. Default setting of Remote Control from factory is A.

Unit B setup.

Press and hold MODE button for more than 20 seconds.

When A setup changed to B setup : 5 beeps will sound and operation lamp blinks for 5 seconds.

When B setup changed to A setup : 5 beeps will sound.

20. ADJUSTING BRIGHTNESS OF UNIT DISPLAY PANEL

1. Press and hold AIR OUTLET SELECT button then press MODE button for 3 times (All lamp of the unit display panel will be switched on).
(At that time, please press and hold the AIR OUTLET SELECT button)
2. Press and hold AIR OUTLET SELECT button on Unit display panel, then press TEMPERATURE button (Up), (Down) for select the desired brightness.
3. Brightness will be settled when AIR OUTLET SELECT button is released.
Although the temperature indicator is switched off, if press the temperature button (up) and (down), the set temperature will be indicated, and then can adjust the temperature.
10 seconds after stopped pressing the button, the temperature indication will be switched off.

4 stages of brightness can be changed.

	Temperature indicator	Other lamp
1	Usual	Usual
2	Darkness	Darkness
3	Turn off	Darkness
4	Turn off	Turn off

21. CHANGE AIR OUTLET GRILLE ON STABLE TIME (COOLING ONLY)

On cooling operation, whichever air outlet is set, only Upper is used when the room temperature approaches the set temperature.

In case to keep pu/down blowing, operate as below;

Press and hold AIR OUTLET SELECT button for more than 10 seconds (less than 20 seconds) (4 beeps will sound then "1" indication at TEMPERATURE indicator will light up for 5 seconds).

For return to the former status, press and hold AIR OUTLET SELECT button for more than 4 seconds once again (In this time, 4 beeps will sound then "0" indication at TEMPERATURE indicator will blink for 5 seconds).

22. AIR INLET GRILLE MAINTENANCE

Wash the air inlet grille with water using the soft sponge or towel.

- Dry it well in a shadow area after washing.
- Scour heavy dirt with neutral detergent for kitchen, and rinse it with the water (Do not use the wire wool).
- Do not press the front panel strongly. It may be cracked.

9-4-3. Name and Functions of Indications on Remote Controller



[Display]

All indications, except for the clock time indicator, are displayed by pressing the  button.

1 Transmission mark

This transmission mark  indicates when the remote controller transmits signals to the indoor unit.







2 Mode indicator

Indicates the current operation mode.
(A : Auto changeover control,
 : Cool,  : Dry,  : Heat)

3 Temperature indicator

Indicates the temperature setting.
(17°C to 30°C)

4 FAN speed indicator

Indicates the selected fan speed.
AUTO or five fan speed levels
(LOW , LOW+ , MED , MED+ , HIGH ) can be shown.
Indicates AUTO when the operating mode is either AUTO or  : Dry.

5 TIMER and clock time indicator

The time setting for timer operation or the clock time is indicated.
The current time is always indicated except during TIMER operation.

6 Hi-POWER indicator

Indicates when the Hi-POWER operation starts.
Press the Hi-POWER button to start and press it again to stop the operation.

7 (PRESET) indicator

Flashes for 3 seconds when the PRESET button is pressed during operation.
The  mark is shown when holding down the button for more than 3 seconds while the mark is flashing.
Press another button to turn off the mark.

8 ECO indicator

Indicates when the ECO is in activated.
Press the ECO button to start and press it again to stop operation.

9 A, B change indicator remote controller

When the remote controller switching function is set, "B" appears in the remote controller display.
(When the remote controller setting is "A", there is no indication at this position.)

10 Comfort sleep

Indicates when comfort sleep is activated.
Press comfort sleep button to selectter

11 Quiet

Indicates when quiet is activated.
Press quiet button to start and press it again to stop operation.

12 One-Touch

Indicates when one touch comfort is activated.
Press one-touch button to start the operation.

13 Swing

Indicates when louver is swing.
Press swing button to start the swing operation and press it again to stop the swing operation.

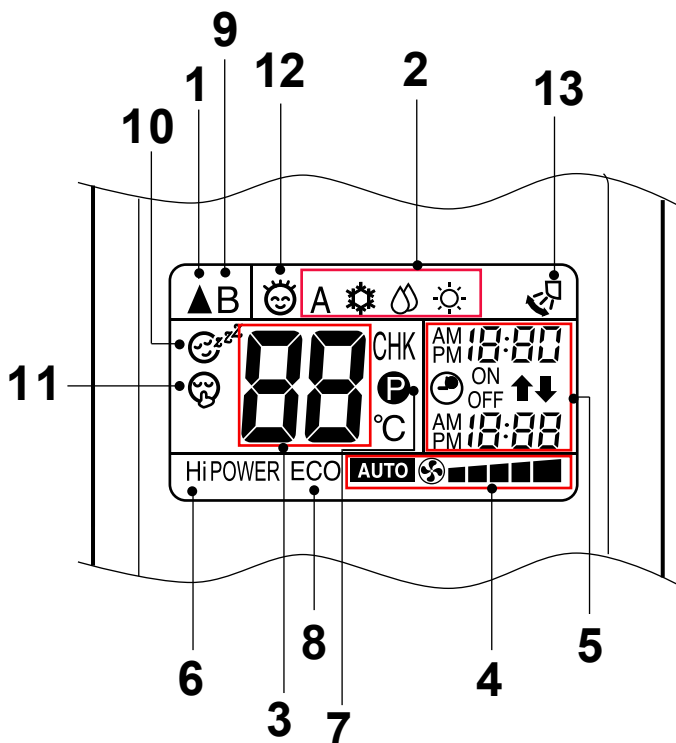

9-5. Indoor Unit Display & Unit Operation Panel

This indoor unit can be operated with the unit operation panel or using remote control.

Operational contents will be followed the one which was operated later.

If change the set temperature with operation panel of unit, temperature indication will be changed, but the temperature display on the remote control will not change.

If set the air flow only with the upper port, a little air flow may happen at the lower port.

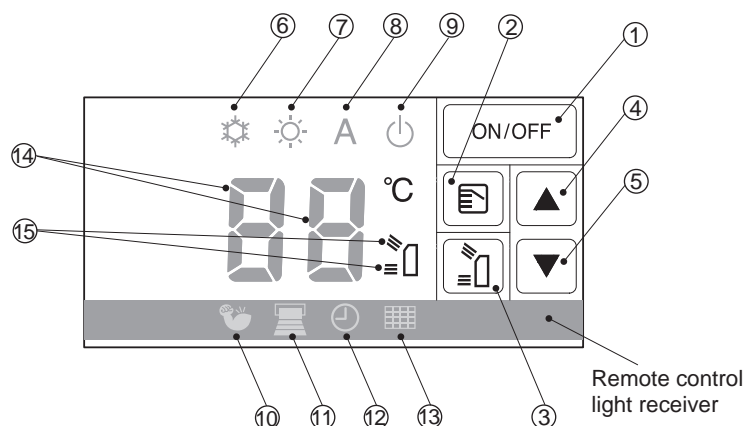

- ① OPERATION button : Unit operation ON/OFF button, turn off FILTER CHECK indicator.
- ② MODE button : Operation mode (Auto→Cooling→Heating→Auto→•••)
- * CHILD LOCK function : Press MODE button for 3 seconds. (It is possible to operate even when stopping.)
 To cancel CHILD LOCK function, press MODE button for 3 seconds once again.
 When CHILD LOCK function is activated, 3 beeps will sound.
 When press MODE button to cancel the function, a beep will sound and then 3 seconds later 3 beep sound may occur.
 The indicator button will be invalid while the child lock function is activated.
 (When press the button, 1 beep will sound).
 Operation with remote control during the CHILD LOCK function works.
 This function is cancelled when the power supply is off or failure.
- ③ AIR OUTLET SELECT button : Cooling, Auto (Upper & Lower→Upper→Upper & Lower→•••)
 Dry (upper only)
 Heating (Upper & Lower→Upper→Upper & Lower→•••)
 On cooling operation, whichever air outlet is set, only Upper is used when the room temperature approaches the set temperature.
 During stop operation : Open/Close the lower air outlet grille.
 When the TEMPERATURE indicator display "CL" the lower air outlet grille will be in closed status.
 When the TEMPERATURE indicator display "OP" the lower air outlet grille will be in open status.
- ④ TEMPERATURE button (Up) : Setting temperature increase by 1°C (17°C→18°C••• 30°C)
- ⑤ TEMPERATURE button (Down) : Setting temperature decrease by 1°C (30°C→ 29°C••• 17°C)
- ⑥ COOL and DRY indicator (Blue)
- ⑦ HEAT indicator (Orange)
- ⑧ AUTO indicator (Green)
- ⑨ OPERATION indicator (Green)
- ⑩ HI-POWER indicator (Green)
- ⑪ FLOOR indicator (Orange)
- ⑫ TIMER indicator (Yellow)
- ⑬ FILTER CHECK indicator (Red)
- ⑭ TEMPERATURE indicator (Blue)
- ⑮ AIR OUTLET indicator (Green)

10. INSTALLATION PROCEDURE

10-1. Installation Diagram of Indoor and Outdoor Units

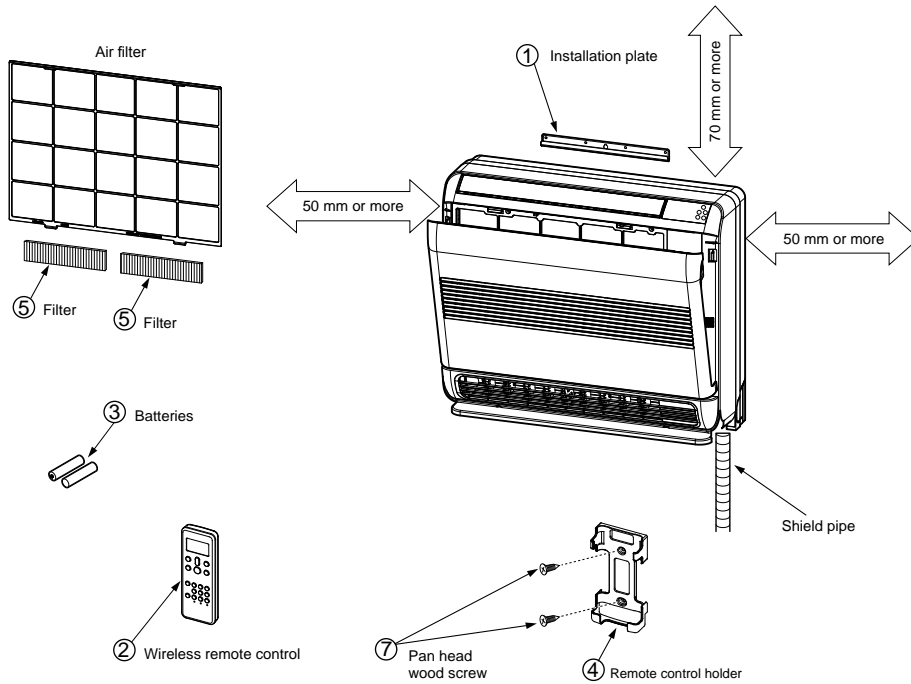

Do not allow the drain hose to get slack.

Cut the piping hole sloped slightly.

Make sure to run the drain hose sloped downward.

The auxiliary piping can be connected to the left, rear left, rear right, right, bottom right or bottom left.

Insulate the refrigerant pipes separately with insulation, not together.

8 mm thick heat resisting polyethylene foam

In case of right or left piping

cut dot-line area

Heat insulation block can cut to an appropriate size and use for completely fill pipe hole to protect water dew.

Heat insulation block

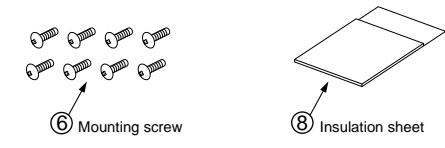

When installing the outdoor unit, leave open in at least two of direction (A), (B), (C) and (D) shown in the figure on the right.

Remark :
 • Detail of accessory and installation parts can see in the accessory sheet.

CAUTION
 Install in rooms that are 13 m³ or larger.
 If a leak of refrigerator gas occurs inside the room, an oxygen deficiency can occur.

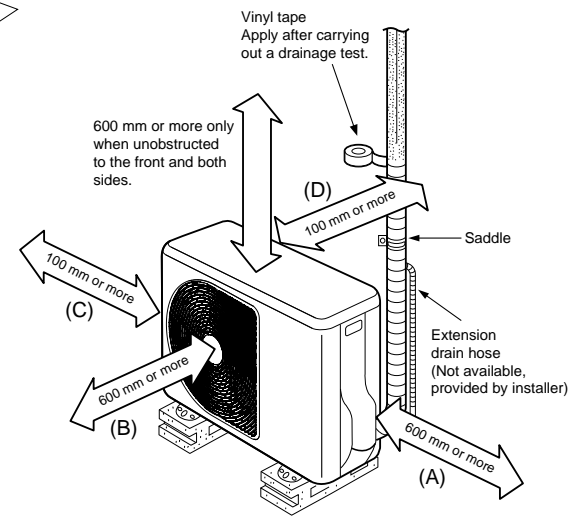

Before installing the wireless remote controller

- Loading Batteries
 1. Remove the battery cover.
 2. Insert 2 new batteries (AAA type) following the (+) and (-) positions.

② Wireless remote controller

③ Batteries

10-2. Optional Parts, Accessories and Tools

10-2-1. Optional Installation Parts

Part Code	Parts name	Q'ty
Ⓐ	Refrigerant piping Liquid side : $\varnothing 6.35$ mm Gas side : $\varnothing 9.52$ mm (RAS-(B) 10,13UFV Series) $\varnothing 12.70$ mm (RAS-(B) 18UFV Series)	One each
Ⓑ	Pipe insulating material (polyethylene foam, 8 mm thick)	1
Ⓒ	Putty, PVC tapes	One each

<Fixing bolt arrangement of outdoor unit>

- Secure the outdoor unit with fixing bolts and nuts if the unit is likely to be exposed to a strong wind.
- Use $\varnothing 8$ mm or $\varnothing 10$ mm anchor bolts and nuts.
- If it is necessary to drain the defrost water, attach drain nipple ⑨ and cap water proof ⑩ to the bottom plate of the outdoor unit before installing it.

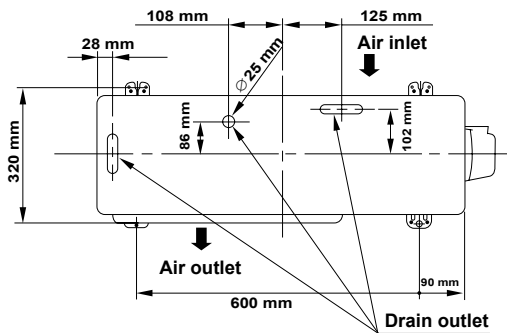





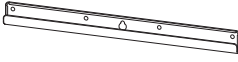
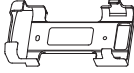

* Drain nipple and cap water proof are packed in outdoor unit.

Fig. 10-2-1

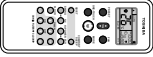
When using a multi-system outdoor unit is used, refer to the installation manual provided with the model concerned.

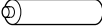
10-2-2. Accessory and installation parts

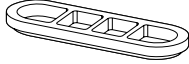
Part No.	Part name (Q'ty)	Part No.	Part name (Q'ty)	Part No.	Part name (Q'ty)			
①	 Installation plate x 1	④	 Remote control holder x 1	⑦	 Flat head wood screw Ø 3.1 x 16 l x 2			
②	 Wireless remote control x 1	⑤	 Filter (RB-A620DE) x 2	⑧	 Insulation sheet x 1			
③	 Battery x 2	⑥	 Mounting screw Ø 4 x 25 l x 8	⑨	 Drain nipple* x 1			
Others	<table border="1"> <thead> <tr> <th>Name</th> </tr> </thead> <tbody> <tr> <td>Owner's manual</td> </tr> <tr> <td>Installation manual</td> </tr> </tbody> </table>	Name	Owner's manual	Installation manual			⑩	 Cap water proof x 2
Name								
Owner's manual								
Installation manual								

The part marked with asterisk (*) is packaged with the outdoor unit.







10-2-3. Installation/Service Tools

Changes in the product and components

In the case of an air conditioner using R410A, in order to prevent any other refrigerant from being charged accidentally, the service port diameter of the outdoor unit control valve (3 way valve) has been changed. (1/2 UNF 20 threads per inch)

- In order to increase the pressure resisting strength of the refrigerant piping flare processing diameter and size of opposite side of flare nuts has been changed. (for copper pipes with nominal dimensions 1/2 and 5/8)

New tools for R410A

New tools for R410A	Applicable to R22 model		Changes
Gauge manifold	×		As pressure is high, it is impossible to measure by means of conventional gauge. In order to prevent any other refrigerant from being charged, each port diameter has been changed.
Charge hose	×		In order to increase pressure resisting strength, hose materials and port size have been changed (to 1/2 UNF 20 threads per inch). When purchasing a charge hose, be sure to confirm the port size.
Electronic balance for refrigerant charging	○		As pressure is high and gasification speed is fast, it is difficult to read the indicated value by means of charging cylinder, as air bubbles occur.
Torque wrench (nominal diam. 1/2, 5/8)	×		The size of opposite sides of flare nuts have been increased. Incidentally, a common wrench is used for nominal diameters 1/4 and 3/8.
Flare tool (clutch type)	○		By increasing the clamp bar's receiving hole, strength of spring in the tool has been improved.
Gauge for projection adjustment	—	—	Used when flare is made by using conventional flare tool.
Vacuum pump adapter	○		Connected to conventional vacuum pump. It is necessary to use an adapter to prevent vacuum pump oil from flowing back to the charge hose. The charge hose connecting part has two ports-one for conventional refrigerant (7/16 UNF 20 threads per inch) and one for R410A. If the vacuum pump oil (mineral) mixes with R410A a sludge may occur and damage the equipment.
Gas leakage detector	×		Exclusive for HFC refrigerant.

- Incidentally, the “refrigerant cylinder” comes with the refrigerant designation (R410A) and protector coating in the U. S's ARI specified rose color (ARI color code: PMS 507).
- Also, the “charge port and packing for refrigerant cylinder” require 1/2 UNF 20 threads per inch corresponding to the charge hose's port size.

10-3. Indoor Unit

10-3-1. Installation Place

- A place which provides the spaces around the indoor unit as shown in the diagram.
- A place where there are no obstacles near the air inlet and outlet.
- A place which allows easy installation of the piping to the outdoor unit.
- A place which allows the front panel to be opened.

CAUTION

- Direct sunlight to the indoor unit's wireless receiver should be avoided.
- The microprocessor in the indoor unit should not be too close to RF noise sources.
(For details, see the owner's manual)

Remote control

- A place where there are no obstacles such as a curtain that may block the signal from the remote control.
- Do not install the remote control in a place exposed to direct sunlight or close to a heating source such as a stove.
- Keep the remote control at least 1 m apart from the nearest TV set or stereo equipment (This is necessary to prevent image disturbances or noise interference).
- The location of the remote control should be determined as shown below.

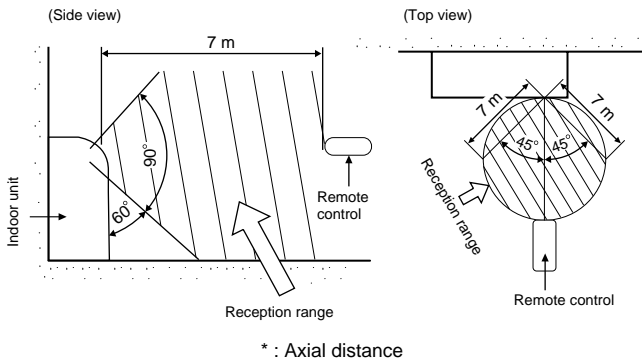

10-3-2. Cutting a Hole and Mounting Installation Plate

Cutting a hole

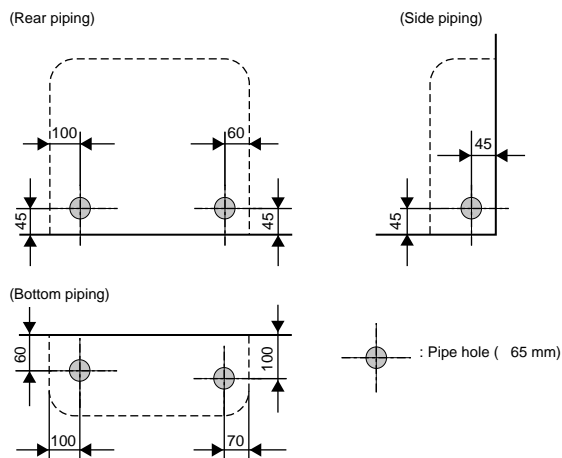

1. After determining the pipe hole position, drill the pipe hole ($\varnothing 65$ mm) at a slight downward slant to the outdoor side.

NOTE

- When drilling a wall that contains a metal lath, wire lath or metal plate, be sure to use a pipe hole brim ring sold separately.

Mounting the installation plate and screw position

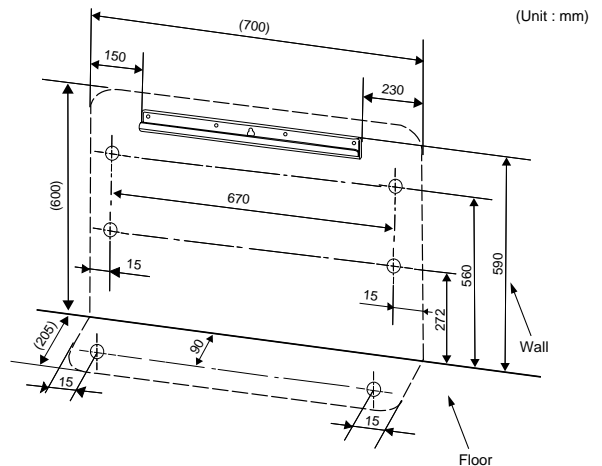

When the installation plate is directly mounted on the wall

1. Securely fit the installation plate onto the wall by screwing it in the upper and lower parts to hook up the indoor unit.
2. To mount the installation plate on a concrete wall with anchor bolts, use the anchor bolt holes as illustrated in the below figure.
3. Install the installation plate horizontally in the wall.

Installation plate
(Keep horizontal direction)

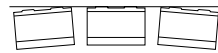

5 mm hole

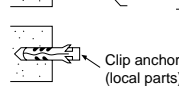
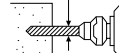

⑥ Mounting screw
 $\varnothing 4$ mm x 25 ℓ

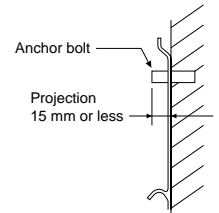

CAUTION

Failure to firmly install the unit may result in personal injury and property damage if the unit falls.

- In case of block, brick, concrete or similar type walls, make $\varnothing 5$ mm holes in the wall.
- Insert clip anchors for appropriate mounting screws ⑥.

10-3-3. How to Install Indoor Unit

1. Remove the air inlet grille. Open the air inlet grille and remove the strap.
2. Remove the front panel (Remove the 4 screws).

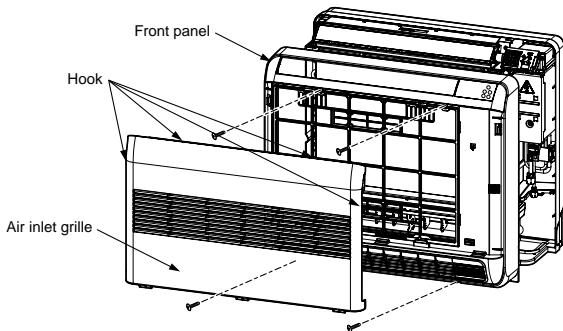

Layout of connection piping

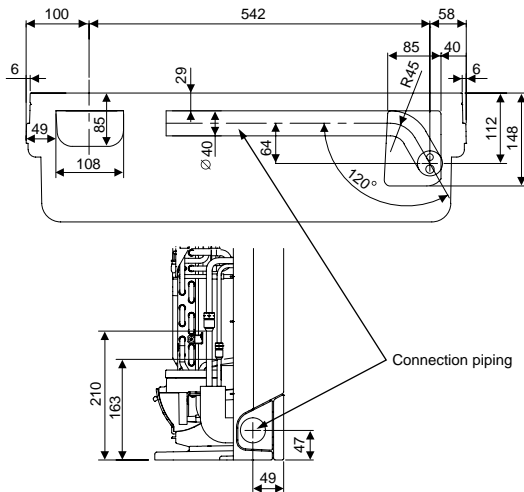

Treatment of piping connection

- 1) Check the flare nut connections for the gas leak with a gas leak detector or soap water.
- 2) To prevent gap in slit, fasten top and bottom with tape.
- 3) Slit is covered with tape.
- 4) Fasten with supplied Insulate sheet to prevent gap on the top of slit.

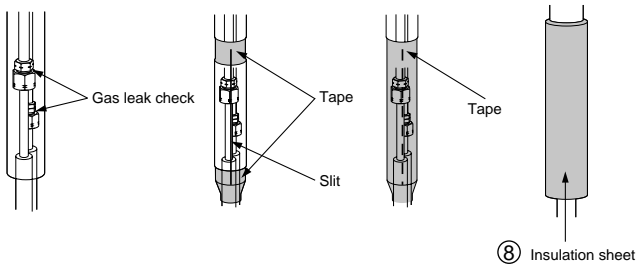

Drainage

1. Run the drain hose sloped downwards.

NOTE

- The hole should be made at a slight downward slant on the outdoor side.

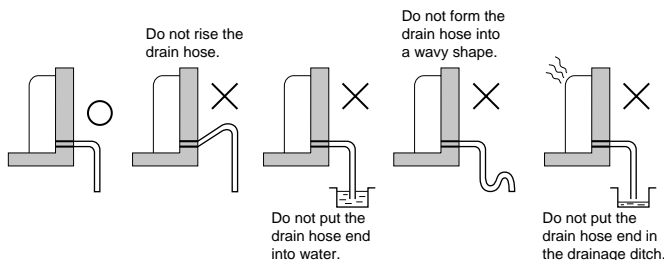

2. Put water in the drain pan and make sure that the water is drained out of doors.
3. When connecting extension drain hose, insulate the connecting part of extension drain hose with shield pipe.

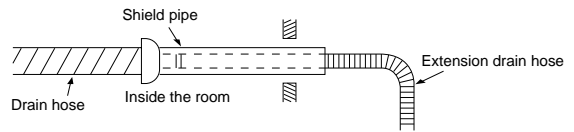

CAUTION

Arrange the drain pipe for proper drainage from the unit. Improper drainage can result in dew-dropping.

Wiring connection

Wiring of the connection cable is necessary to remove the front panel.

1. Remove the terminal cover and cord clamp.
2. Insert the connecting cable (according to the local rule) into the pipe hole on the wall.
3. Take out the connecting cable through the cable slot on the rear panel so that it protrudes about 50 cm from the front.
4. Insert the connecting cable fully into the terminal block and secure it tightly with screws.
5. Tightening torque : 1.2 N·m (0.12 kgf·m)
6. Secure the connecting cable with the cord clamp.
7. Fix the terminal cover, install the front panel and grille inlet.

CAUTION

- Be sure to refer to the wiring system diagram labeled inside the front panel.
- Check local electrical cords and also any specific wiring instructions or limitations.

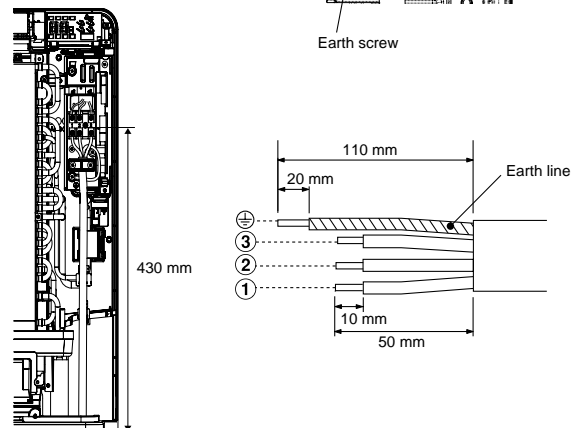
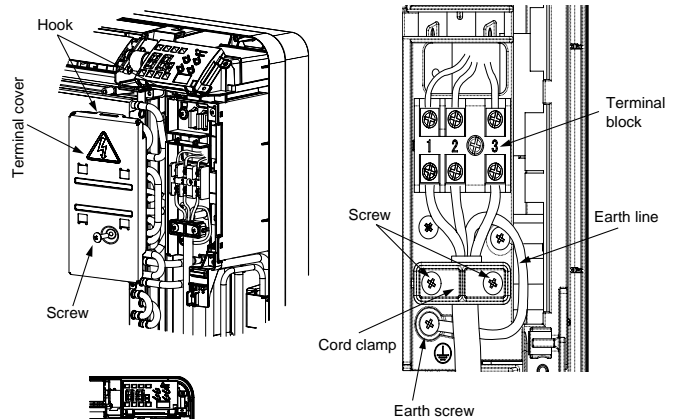

Stripping length of the connecting cable

NOTE

- Use stranded wire only.
- Wire type : H07RN-F or 60245 IEC66 (1.0 mm² or more)

Mounting directly on the floor

- 1) Fix the leg of indoor unit on the floor with 2 mounting screws.
- 2) Fix the upper part of indoor unit on the wall with 4 mounting screws.

(Floor installation)

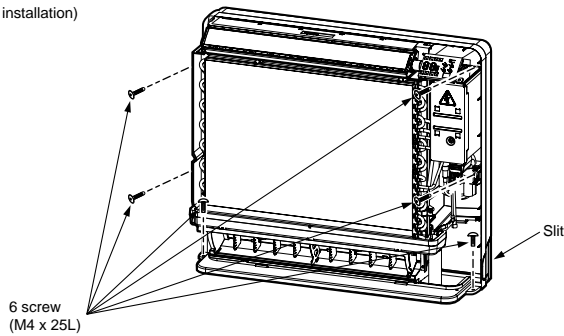

NOTE

- In case the plinth is fixed to the wall, please make sure to cut out the slit on the left and right side of the main part.

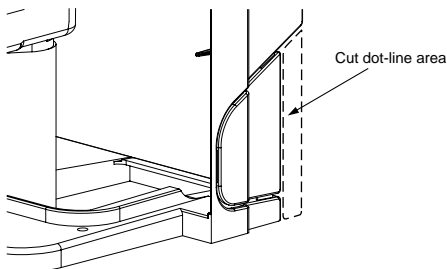

Installation on the wall

- 1) Fix the installation plate on the wall with 4 mounting screws.
- 2) Hook the indoor unit on the installation plate.
- 3) Fix the upper part of indoor unit on the wall with 4 mounting screws.

(Wall installation)

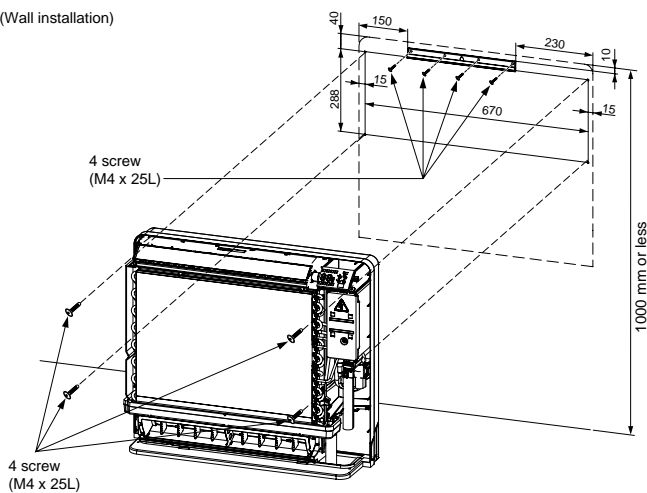

CAUTION

Make sure to fix it at a designated position with the screws.
Failure may result the damage of piping by the turning over of a set.

10-3-4. Concealed Installation

The special method to install the indoor unit bury in the wall is shown here. Please make sure to change to wall burying mode.

1. To switch to the wall burying mode
 - To switch to the wall burying mode, press and hold AIR OUTLET SELECT button for 20 seconds.
 - When the operation set up and 5 beep sounds. Then indication at Temperature indicator will light up for 5 seconds.
 - To cancel, press AIR OUTLET SELECT button for 20 seconds then, 5 beep sounds. Then indication at Temperature indicator will blinks for 5 seconds.
 - To prevent dewfall, above plate angle should be narrow.

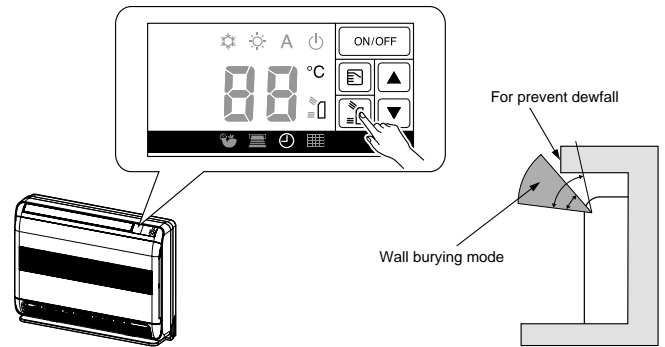

2. Wall hole size

Wall hole size should be enough to keep the distance with indoor unit as shown in the following figure.

(Front view)

(Unit : mm)

(Side view)

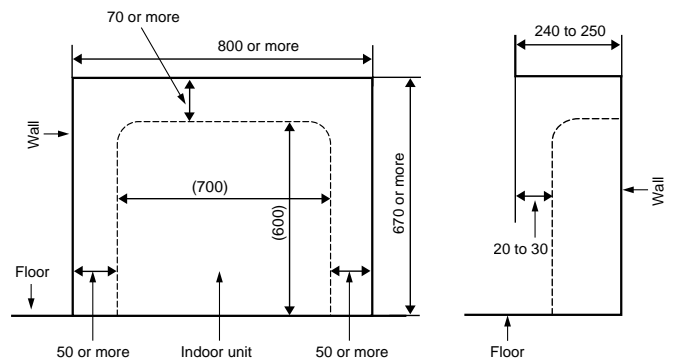

3. Installation using the supporting plate

- To install into the existing wall hole, if it is impossible to keep 20-30 mm of depth, use the supporting plate for securing the distance.
- Arrange the screw positions and supporting plate as shown in the figure.
- Be sure to switch to wall burying mode.

(Rear screws position)

(Side view)

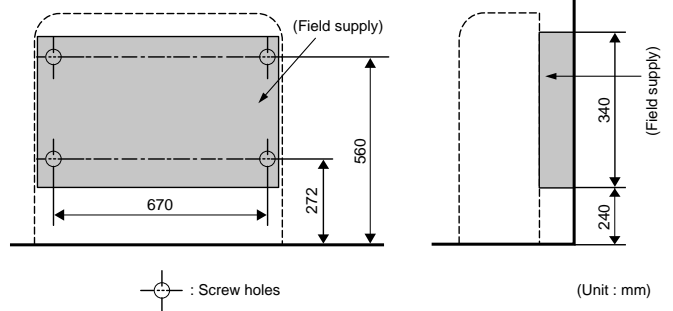

⊕ : Screw holes

(Unit : mm)

4. In case of lattice establishment

- Follow the following figure, make sure to keep enough distance between lattice, frame and wall.
- Be sure to switch to wall burying mode.
- The lattice should be made of wood.
- Between the air inlet and outlet, should be divided with partition board.
- Be sure to establish the open part for RECEIVER.
- The open part of lattice must be open 70% or more of the wall hole.
- The open part of lattice must be arranged uniformly.

(Top view)

(Unit : mm)

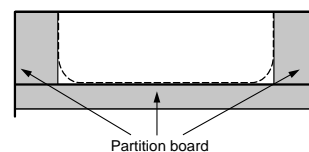

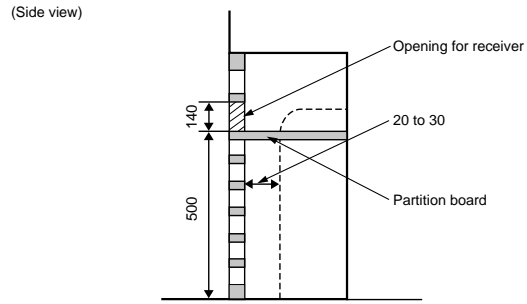
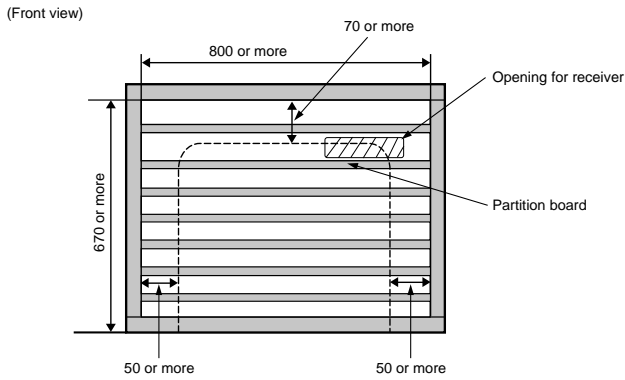

10-4. OUTDOOR UNIT

- When using a multi-system outdoor unit refer to the installation manual provided with the model concerned.

10-4-1. Installation Place

- A place which provides enough spaces around the outdoor unit as shown in the diagram.
- A place which can bear the weight of the outdoor unit and does not allow an increase in noise level and vibration.
- A place where the operation noise and discharged air do not disturb your neighbors.
- A place which is not exposed to a strong wind.
- A place free of a leakage of combustible gases.
- A place which does not block a passage.
- When the outdoor unit is to be installed in an elevated position, be sure to secure its feet.
- This air conditioner accepts a connection piping length from 2 m to 20 m.
 - There is no need to add refrigerant as long as the length of the connection piping is 15 m or less.
 - You will need to add 20 g of refrigerant per meter of added connection piping for installation requiring connection piping to be between 16 m to 20 m.
- An allowable height level is up to 10 m.
- A place where the drain water does not cause any problems.

10-4-2. Precautions about Installation in Regions with Snowfall and Cold Temperatures

- Do not use the supplied drain nipple for draining water. Drain the water from all the drain holes directly.
- To protect the outdoor unit from snow accumulation, install a holding frame, and attach a snow protection hood and plate.
- Do not use a double-stacked design.

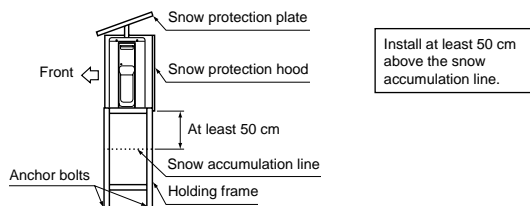

CAUTION

- Install the outdoor unit in a location where there are no obstructions near its air intake or air outlet.
- When the outdoor unit is installed in a place that is always exposed to strong winds like on the coast or on a high story of a building, secure the normal fan operation using a duct or a wind shield.
- Especially in windy areas, install the unit to prevent the admission of wind.
- Installation in the following places may result in trouble. Do not install the unit in such places.
 - A place full of machine oil.
 - A saline-place such as the coast.
 - A place full of sulfide gas.
 - A place where high-frequency waves are likely to be generated, such as from audio equipment, welders, and medical equipment.

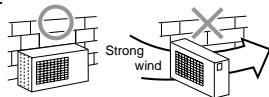

10-4-3. Draining off the Water from the Outdoor Unit

- If it is necessary to drain off the water from the outdoor unit, install two water-proofing rubber caps and a drain nipple.

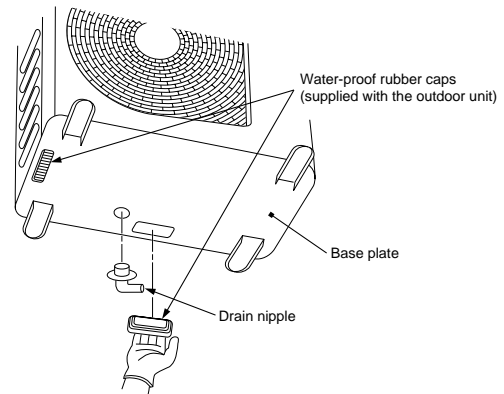

10-4-4. Refrigerant Piping Connection

Flaring

- Cut the pipe with a pipe cutter.
- Deburr the inside of the pipe at its end.
 - Take steps to ensure that the removed burrs will not enter the pipe.
- Remove the flare nuts provided with the indoor and outdoor units, and insert them into the pipe.
- Flare the pipe.
 - The projection margin of the pipe must be checked.
- Check that the flare has the appropriate shape.

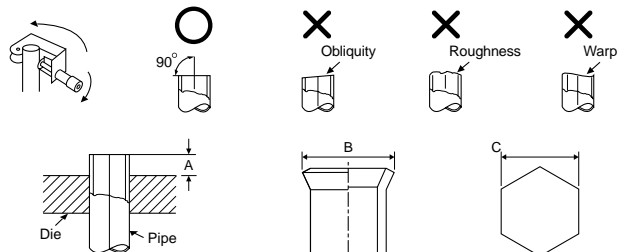

Pipe		A		B		Flare Nut	
Outside diameter	Thickness	Rigid (clutch type) R410A tool	Imperial (wing nut type) R410A tool	C		Tighten torque	
mm	mm	mm	mm	mm	mm	N-m	kgf-m
6.35	0.8	0 to 0.5	1.5 to 2.0	9.1	17	14 to 18	1.4 to 1.8
9.52	0.8	0 to 0.5	1.5 to 2.0	13.2	22	33 to 42	3.3 to 4.2
12.7	0.8	0 to 0.5	2.0 to 2.5	16.6	26	50 to 62	5.0 to 6.2

- Tightening torque for connection of flare pipe - The pressure of R410A is higher than R22 (Approx. 1.6 times). Therefore securely tighten the flare pipes which connect the outdoor unit and the indoor unit with the specified tightening torque using a torque wrench. If any flare pipe is incorrectly connected, it may cause not only a gas leakage but also trouble in the refrigeration cycle.

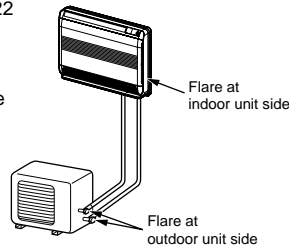

Gas side (∅12.70 mm)	50 to 62 N·m (5.0 to 6.2 kgf·m)
Gas side (∅9.52 mm)	33 to 42 N·m (3.3 to 4.2 kgf·m)
Liquid side (∅6.35 mm)	14 to 18 N·m (1.4 to 1.8 kgf·m)
Service port	14 to 18 N·m (1.4 to 1.8 kgf·m)

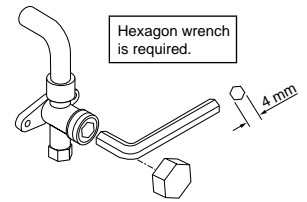

10-4-5. Evacuating

After the piping has been connected to the indoor unit, you can perform vacuuming together at once.

VACUUMING

Evacuate the air in the connecting pipes and in the indoor unit using a vacuum pump. Do not use the refrigerant in the outdoor unit. For details, see the manual of the vacuum pump.

Using a vacuum pump

Be sure to use a vacuum pump with counter-flow prevention function so that inside oil of the pump does not flow backward into pipes of the air conditioner when the pump stops. (If oil inside of the vacuum pump enters the air conditioner, which use R410A, refrigeration cycle trouble may happen.)

1. Connect the charge hose from the manifold valve to the service port of the packed valve at gas side.
2. Connect the charge hose to the port of the vacuum pump.
3. Open fully the low pressure side handle of the gauge manifold valve.
4. Operate the vacuum pump to start evacuating. Perform evacuating for about 15 minutes if the piping length is 20 meters (15 minutes for 20 meters) (assuming a pump capacity of 27 liters per minute). Then confirm that the compound pressure gauge reading is -101 kPa (-76 cmHg).
5. Close the low pressure side valve handle of the gauge manifold valve.
6. Open fully the valve stem of the packed valves (both gas and liquid sides).
7. Remove the charging hose from the service port.
8. Securely tighten the caps on the packed valves.

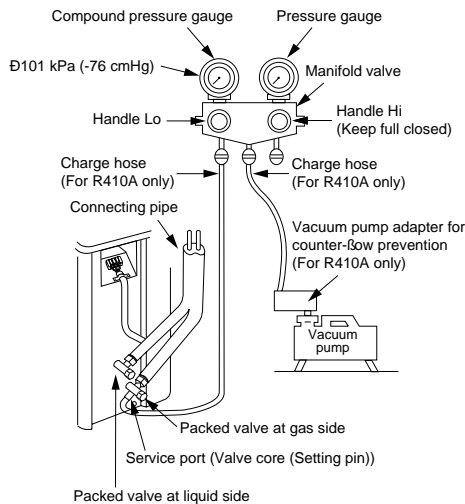

CAUTION

- KEEP IMPORTANT 5 POINTS FOR PIPING WORK.
 - (1) Take away dust and moisture (inside of the connecting pipes).
 - (2) Tighten the connections (between pipes and unit).
 - (3) Evacuate the air in the connecting pipes using a VACUUM PUMP.
 - (4) Check gas leak (connected points).
 - (5) Be sure to fully open the packed valves before operation.

Packed valve handling precautions

- Open the valve stem until it touches the stopper. Once it is in contact with the stopper, refrain from applying any more force than is necessary.
- Securely tighten the valve stem cap with torque in the following table:

10-4-6. Wiring Connection

1. Remove the valve cover, the electric parts cover and the cord clamp from the outdoor unit.
2. Connect the connecting cable to the terminal as identified by the matching numbers on the terminal block of indoor and outdoor unit.
3. Insert the power cord and the connecting cable fully into the terminal block and secure it tightly with screws.
4. Use vinyl tape, etc. to insulate the cords which are not going to be used. Locate them so that they do not touch any electrical or metal parts.
5. Secure the power cord and the connecting cable with the cord clamp.
6. Attach the electric parts cover and the valve cover on the outdoor unit.

10-4-7. Electrical Work

1. The supply voltage must be the same as the rated voltage of the air conditioner.
2. Prepare the power source for exclusive use with the air conditioner.

Model	RAS-(B)10UFV series	RAS-(B)13UFV series	RAS-(B)18UFV series
Power source	220-240V ~ 50Hz 220-230V ~ 60Hz	220-240V ~ 50Hz 220-230V ~ 60Hz	220-240V ~ 50Hz 220-230V ~ 60Hz
Maximum running current	8.5A	11.0A	12.0A
Plug socket & fuse rating	16A		
Power cord	H07RN-F or 60245 IEC66 (1.5 mm ² or more)		
Connecting cable	H07RN-F or 60245 IEC66 (1.0 mm ² or more)		

* When using a multi-system outdoor unit is used, refer to the installation manual provided with the model concerned.

Stripping length of the connecting cable

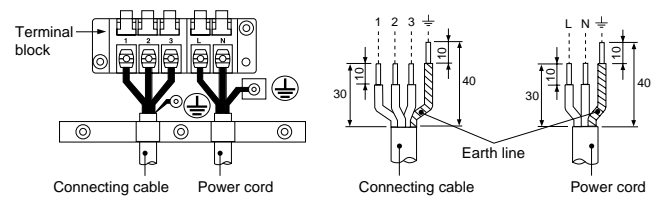

RAS-10SAVR-A, RAS-18SAV-E

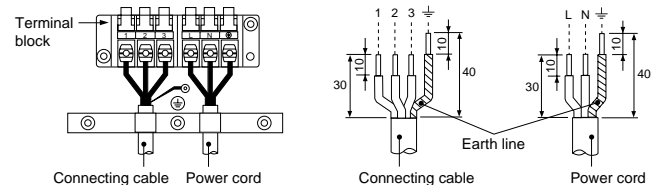

CAUTION

- Wrong wiring connection may cause some electrical parts burn out.
- Be sure to comply with local rule on running the wire from indoor unit to outdoor unit (size of wire and wiring method, etc.).
- Every wire must be connected firmly.
- If incorrect or incomplete wiring is carried out, it will cause an ignition or smoke.
- Prepare the power supply for exclusive use with the air conditioner.
- This product can be connected to the mains. Connection to fixed wiring : A switch which disconnects all poles and has a contact separation of at least 3 mm must be incorporated in the fixed wiring.

10-5. OTHERS

10-5-1. Gas Leak Test

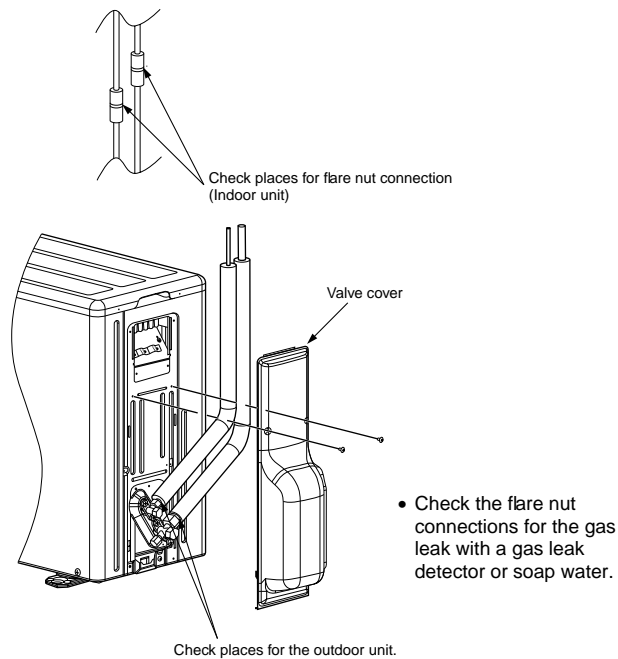

10-5-2. Setting of Remote Control Selector Switch

When two indoor units are installed in the separated rooms, it is not necessary to change the selector switches.

Remote control selector switch

- When two indoor units are installed in the same room or adjacent two rooms, if operating a unit, two units may receive the remote control signal simultaneously and operate. In this case, the operation can be preserved by setting either one indoor unit or remote control to B setting (Both are set to A setting in factory shipment).
- The remote control signal is not received when the settings of indoor unit and remote control are different.
- There is no relation between A setting/B setting and A room/B room when connecting the piping and cables.

10-5-3. Remote Control A-B Selection

To separate using of remote control for each indoor unit in case of 2 air conditioners are installed nearby.

Remote Control B Setup.

1. Push and hold **CHK** button on the Remote Control by the tip of the pencil. "00" will be shown on the display.
2. Press **MODE** during pushing **CHK**. "B" will show on the display and "00" will disappear and the air conditioner will turn OFF. The Remote Control B is memorized.

Note : 1. Repeat above step to reset Remote Control to be A.
2. Remote Control A has not "A" display.
3. Default setting of Remote Control from factory is A.

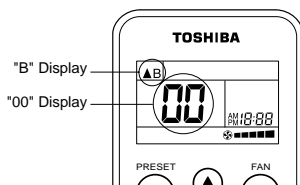

Unit B setup.

Press and hold MODE button for more than 20 seconds.
When A setup changed to B setup : 5 beeps will sound and operation lamp blinks for 5 seconds.
When B setup changed to A setup : 5 beep will sound.

10-5-4. Test Operation

To switch the TEST RUN (COOL) mode, press OPERATION button for 10 seconds (The beeper will make a short beep).

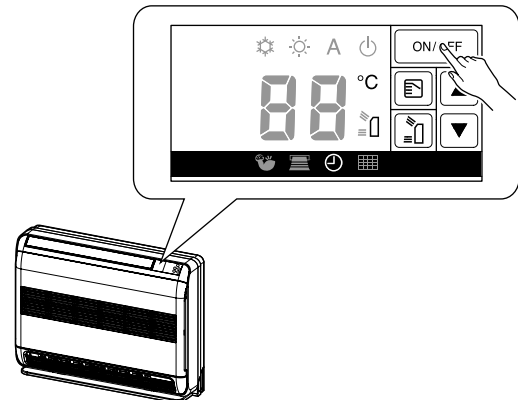

10-5-5. Auto Restart Setting

This product is designed so that, after a power failure, it can restart automatically in the same operating mode as before the power failure.

Information

The product are shipped with Auto Restart function in the off position. Turn it on as required.

How to set the Auto Restart

1. Press and hold OPERATION button on the indoor unit for 3 seconds to set the operation (3 beep sound and OPERATION lamp blink 5 time/sec for 5 seconds).
2. Press and hold OPERATION button on the indoor unit for 3 seconds to cancel the operation (3 beep sound but OPERATION lamp does not blink).
 - In case of ON timer or OFF timer are set, it dose not activate.

11. HOW TO DIAGNOSE THE TROUBLE

The pulse motor circuits are mounted to both indoor and outdoor units. Therefore, diagnose troubles according to the trouble diagnosis procedure as described below. (Refer to the check points in servicing written on the wiring diagrams attached to the indoor/outdoor units.)

Table 11-1

No.	Troubleshooting Procedure
1	First Confirmation
2	Primary Judgment
3	Judgment by Flashing LED of Indoor Unit
4	Self-Diagnosis by Remote Controller
5	Judgment of Trouble by Every Symptom

No.	Troubleshooting Procedure
6	How to Check Simply the Main Parts
7	Troubleshooting
8	How to Diagnose Trouble in Outdoor Unit
9	How to Check Simply the Main Parts
10	How to Simply Judge Whether Outdoor Fan Motor is Good or Bad

◆ Precautions when handling the new inverter (3DV Inverter)

⚠ CAUTION: HIGH VOLTAGE

The high voltage circuit is incorporated.

Be careful to do the check service, as the electric shock may be caused in case of touching parts on the P.C. board by hand.

The new inverter (3DV inverter) will be incorporated starting with this unit.

(3DV: 3-shunt Discrete Vector control)

◆ The control circuitry has an uninsulated construction.

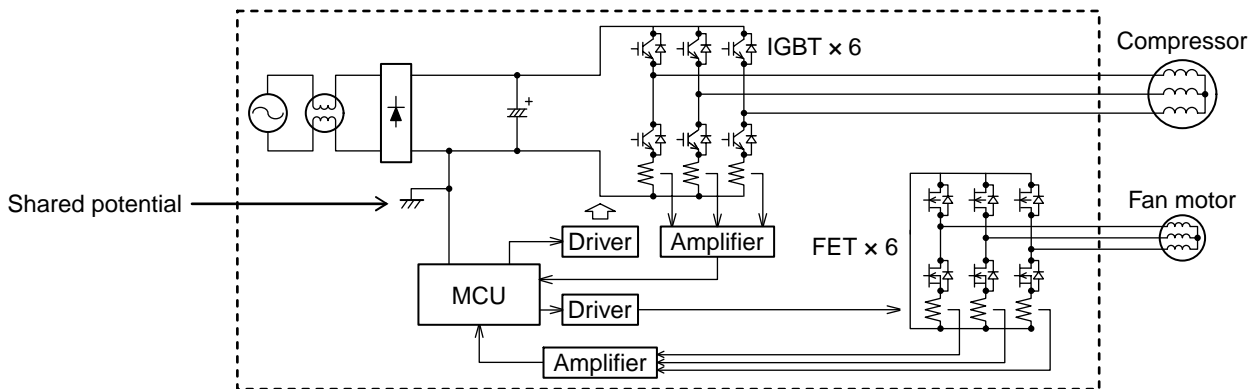

Fig. 11-1

⚠ CAUTION

A high voltage (equivalent to the supply voltage) is also energized to ground through the sensors, PMV and other low-voltage circuits. The sensor leads and other wires are covered with insulated tubes for protection. Nevertheless, care must be taken to ensure that these wires are not pinched.

Take sufficient care to avoid directly touching any of the circuit parts without first turning off the power.

At times such as when the circuit board is to be replaced, place the circuit board assembly in a vertical position.

Laying the board flat on an electrically conductive object (such as the top panel of the air conditioner's outdoor unit) while a charge is still retained by the electrolytic capacitors of the inverter's main circuit may cause short-circuiting between the electrolytic capacitors and secondary circuit components and result in damage to the components.



Sensor leads

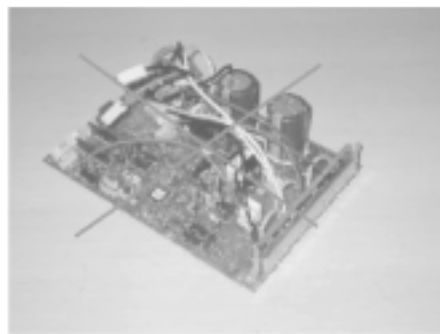

Fig. 11-2

Do NOT lay the circuit board assembly flat.

◆ **Precautions when inspecting the control section of the outdoor unit**

NOTE :

A large-capacity electrolytic capacitor is used in the outdoor unit controller (inverter). Therefore, if the power supply is turned off, charge (charging voltage DC280 to 380V) remains and discharging takes a lot of time. After turning off the power source, if touching the charging section before discharging, an electrical shock may be caused. Discharge the electrolytic capacitor completely by using soldering iron, etc.

< **Discharging method** >

1. Remove the inverter cover (plating) by opening four mounting claws.
2. As shown below, connect the discharge resistance (approx. 100. 40W) or plug of the soldering iron to voltage between + – terminals of the C14 ("CAUTION HIGH VOLTAGE" is indicated.) electrolytic capacitor on P.C. board, and then perform discharging.

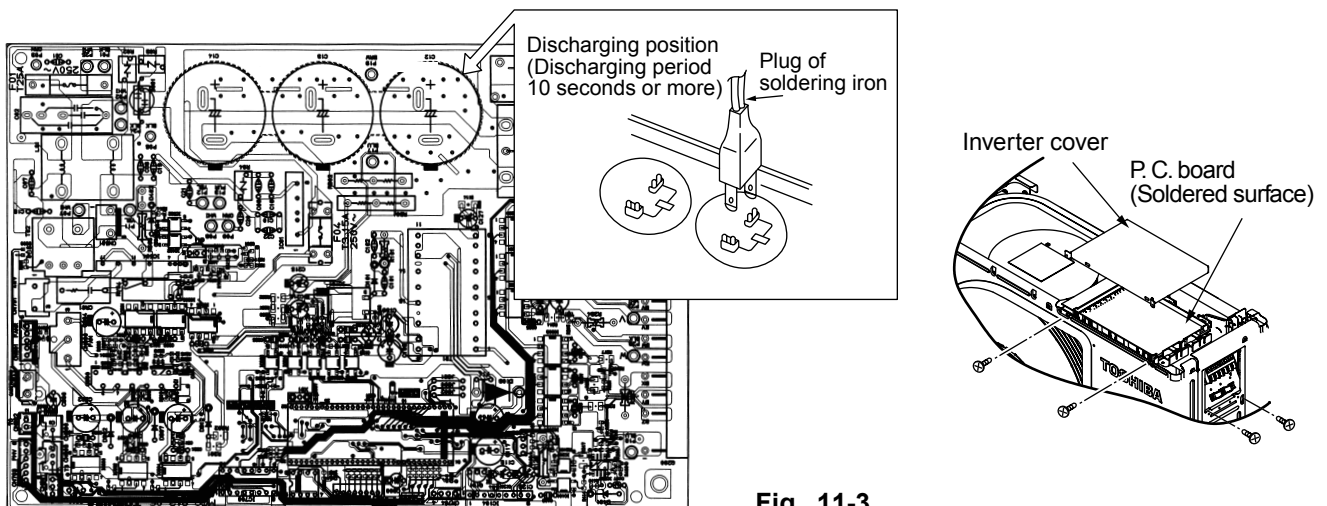

Fig. 11-3

11-1. First Confirmation

11-1-1. Confirmation of Power Supply

Confirm that the power breaker operates (ON) normally.

11-1-2. Confirmation of Power Voltage

Confirm that power voltage is AC 220–230–240 ± 10%.

If power voltage is not in this range, the unit may not operate normally.

11-1-3. Operation Which is not a Trouble (Program Operation)

For controlling the air conditioner, the program operations are built in the microcomputer as described in the following table.

If a claim is made for running operation, check whether or not it meets to the contents in the following table.

When it does, we inform you that it is not trouble of equipment, but it is indispensable for controlling and maintaining of air conditioner.

Table 11-1-1

No.	Operation of air conditioner	Description
1	When power breaker is turned "ON", the operation indicator (Green) of the indoor unit flashes.	The operation indicator of the indoor unit flashes when power source is turned on. If [START/STOP] button is operated once, flashing stops. (Flashes also in power failure)
2	Compressor may not operate even if the room temperature is within range of compressor-ON.	The compressor does not operate while compressor restart delay timer (3-minutes timer) operates. The same phenomenon is found after power source has been turned on because 3-minutes timer operates.
3	In Dry and ECO mode, FAN (air flow) display does not change even though FAN (air flow select) button is operated.	The air flow indication is fixed to [AUTO].
4	Increasing of compressor motor speed stops approx. 30 seconds after operation started, and then compressor motor speed increases again approx. 30 seconds after.	For smooth operation of the compressor, the compressor motor speed is restricted to Max. 41 rps for 2 minutes, and Max.91 rps for 2 minutes to 3 minutes, respectively after the operation has started.
5	In AUTO mode, the operation mode is changed.	After selecting Cool or Heat mode, select an operation mode again if the compressor keeps stop status for 15 minutes.
6	In HEAT mode, the compressor motor speed does not increase up to the maximum speed or decreases before the temperature arrives at the set temperature.	The compressor motor speed may decrease by high-temp. release control (Release protective operation by temp.-up of the indoor heat exchanger) or current release control.

11-2. Primary Judgment

To diagnose the troubles, use the following methods.

- 1) Judgment by flashing LED of indoor unit
- 2) Self-diagnosis by service check remote controller
- 3) Judgment of trouble by every symptom

Firstly use the method 1) for diagnosis. Then, use the method 2) or 3) to diagnose the details of troubles.

11-3. Judgment by Flashing LED of Indoor Unit

While the indoor unit monitors the operation status of the air conditioner, if the protective circuit operates, the contents of self-diagnosis are displayed with block on the indoor unit indication section.

Table 11-3-1

	Item	Check code	Block display	Description for self-diagnosis
<div style="border: 1px solid black; padding: 5px; width: fit-content;">Indoor indication lamp flashes.</div> <div style="margin: 5px 0;">↓</div> <div style="border: 1px solid black; padding: 5px; width: fit-content;">Which lamp does flash?</div> <div style="margin: 5px 0;">↓</div> <div style="border: 1px solid black; padding: 5px; width: fit-content;">C</div>	A	—	OPERATION (Green) Flashing display (1 Hz)	Power failure (when power is ON)
	B	00	OPERATION (Green) Flashing display (5 Hz)	Protective circuit operation for indoor P.C. board
	C	01	OPERATION (Green) TIMER (Yellow) Flashing display (5 Hz)	Protective circuit operation for connecting cable and serial signal system
	D	02	OPERATION (Green) FILTER (Orange) Flashing display (5 Hz)	Protective circuit operation for outdoor P.C. board
	E	03	OPERATION (Green) TIMER (Yellow) FILTER (Orange) Flashing display (5 Hz)	Protective circuit operation for others (including compressor)

NOTES :

1. The contents of items B and C and a part of item E are displayed when air conditioner operates.
2. When item B and C, and item B and a part of item E occur concurrently, priority is given to the block of item B.
3. The check codes can be confirmed on the remote controller for servicing.

11-4. Self-Diagnosis by Remote Controller (Check Code)

1. If the lamps are indicated as shown B to E in Table 11-3-1, execute the self-diagnosis by the remote controller.
2. When the remote controller is set to the service mode, the indoor controller diagnoses the operation condition and indicates the information of the self-diagnosis on the display of the remote controller with the check codes. If a fault is detected, all lamps on the indoor unit will flash at 5Hz and it will beep for 10 seconds (Beep, Beep, Beep ...). The timer lamp usually flashes (5Hz) during self-diagnosis.

11-4-1. How to Use Remote Controller in Service Mode

1 Press [CHECK] button with a tip of pencil to set the remote controller to the service mode.

- “00” is indicated on the display of the remote controller.

2 Press [ON▲] or [OFF▲] button

If there is no fault with a code, the indoor unit will beep once (Beep) and the display of the remote controller will change as follows :

00 → 01 → 02 ... 1d → 1E → 33

- The TIMER indicator of the indoor unit flashes continuously. (5 times per 1 sec.)
- Check the unit with all 52 check codes (00 to 33) as shown in Table-11-4-1.
- Press [ON▼] or [OFF▼] button to change the check code backward.

If there is a fault, the indoor unit will beep for 10 seconds (Beep, Beep, Beep...).

Note the check code on the display of the remote controller.

- 2-digits alphanumeric will be indicated on the display.
- All indicators on the indoor unit will flash. (5 times per 1 sec.)

3 Press [CLR] button. After service finish for clear service code in memory.

- "7F" is indicated on the display of the remote control.

4 Press [⏻] button to release the service mode.

- The display of the remote controller returns to as it was before service mode was engaged.

Alphanumeric characters are used for the check codes.

5	is 5.	6	is 6.
A	is A.	B	is B.
C	is C.	D	is D.

Fig. 11-4-1

11-4-2. Caution at Servicing

1. After servicing, press the [⏪] button to return to the normal mode.
2. After servicing by the check code, turn off breaker of the power supply, and turn on breaker of the power supply again so that memory in the microcomputer returns the initial status.
However, the check codes are not deleted even if the power supply is turned off because they are stored in the fixed memory.
3. After servicing, press [CLR] button under check mode status and then send the check code "7F" to the indoor unit. The error code stored in memory is cleared.

Table 11-4-1

Block distinction		Operation of diagnosis function				Judgment and action
Check code	Block	Check code	Cause of operation	Air conditioner status	Remarks	
00	Indoor P.C. board etc.	01	Short-circuit or disconnection of the room temperature sensor (TA sensor).	Operation continues.	Displayed when error is detected.	1. Check the room temp. sensor. 2. When the room temp. sensor is normal, check P.C. board.
		02	Being out of place, disconnection, short-circuit, or migration of heat exchanger sensor (TC sensor)	Operation continues.	Displayed when error is detected.	1. Check heat exchanger sensor. 2. When heat exchanger sensor is normal, check P.C. board.
		0F	Being out of place, disconnection, short-circuit, or migration of heat exchanger sensor (TCj sensor)	Operation continues.	Displayed when error is detected.	1. Check heat exchanger sensor. 2. When heat exchanger sensor is normal, check P.C. board.
		11	Lock of indoor fan or trouble on the indoor fan circuit	All off	Displayed when error is detected.	1. Check the motor. 2. When the motor is normal, check P.C. board.
	Not displayed	12	Trouble on other indoor P.C. boards	Operation continues.	Displayed when error is detected.	Replace P.C. board.
01	Connecting cable and serial signal	04	Return serial signal is not sent to indoor side from operation started. 1) Defective wiring of connecting cable 2) Operation of compressor thermo Gas shortage Gas leak	Operation continues.	Flashes when trouble is detected on Return serial signal, and normal status when signal is reset.	1. When the outdoor unit never operate: 1) Check connecting cable, and correct if defective wiring. 2) Check 25A fuse of inverter P.C. board. 3) Check 3.15A of inverter P.C. board. 2. To display [Other] block during operation, check compressor thermo. operation and supply gas (check gas leak also). 3. Unit operates normally during check. If return serial signal does not stop between indoor terminal board 2 and 3, replace inverter P.C. board. If signal stops between indoor terminal board 2 and 3, replace indoor P.C. board.

Block distinction		Operation of diagnosis function				Judgment and action
Check code	Block	Check code	Cause of operation	Air conditioner status	Remarks	
02	Outdoor P.C. board	14	Inverter over-current protective circuit operates. (Short time)	All off	Displayed when error is detected.	Even if trying operation again, all operations stop immediately. : Replace P.C. board.
		15	Position-detect circuit error or short-circuit between windings of compressor	All off	Displayed when error is detected.	1. Even if connecting lead wire of compressor is removed, position-detect circuit error occurred. : Replace P.C. board. 2. Measure resistance between wires of compressor, and perform short-circuit. : Replace compressor.
		17	Current-detect circuit error	All off	Displayed when error is detected.	Even if trying operation again, all operations stop immediately. : Replace P.C. board.
		18	Being out of place, disconnection or short-circuit of the outdoor heat exchanger sensor (TE) or suction temp. sensor (TS)	All off	Displayed when error is detected.	1. Check sensors (TE, TS). 2. Check P.C. board.
		19	Disconnection or short-circuit of discharge temp. sensor	All off	Displayed when error is detected.	1. Check discharge temp. sensor (TD). 2. Check P.C. board
		1A	Outdoor fan drive system error	All off	Displayed when error is detected.	Position-detect error, over-current protective operation of outdoor fan drive system, fan lock, etc. : Replace P.C. board or fan motor.
	Not displayed	1B	Outdoor heat exchanger temp. sensor error	Operation continues	—	1. Check outdoor temp. sensor (TO). 2. Check P.C. board.
Outdoor P.C. board	1C	Compressor drive output error, Compressor error (lock, missing, etc.), Break down	All off	Displayed when error is detected.	1. Check power voltage. (220–230–240 V +10%) 2. Overload operation of refrigeration cycle Check installation condition (Short-circuit of outdoor diffuser). 3. When 20 seconds passed after start-up, position-detect circuit error occurred. : Replace compressor. Trouble on P.M.V.	

Block distinction		Operation of diagnosis function				Judgment and action
Check code	Block	Check code	Cause of operation	Air conditioner status	Remarks	
03	Others (including compressor)	07	Return serial signal has been sent when operation started, but it is not sent from halfway. 1) Compressor thermo. operation Gas shortage Gas leak 2) Instantaneous power failure	Operation continues	Flashes when trouble is detected on return serial signal, and normal status when signal is reset.	1. Repeat Start and Stop with interval of approx. 10 to 40 minutes. (Code is not displayed during operation.) Supply gas. (Check also gas leak). 2. Unit operates normally during check. If return serial signal does not stop between indoor terminal block 2 and 3, replace inverter P.C. board. If signal stops between indoor terminal block 2 and 3, replace indoor P.C. board.
		1d	Compressor does not rotate. (Current protective circuit does not operate when a specified time passed after compressor had been activated.)	All off	Displayed when error is detected.	1. Trouble on compressor 2. Trouble on wiring of compressor (Missed phase)
		1E	Discharge temp. exceeded 117°C	All off	Displayed when error is detected.	1. Check discharge temp. sensor (TD). 2. Gas leakage 3. Trouble on P.M.V.
		1F	Break down of compressor	All off	Displayed when error is detected.	1. Check power voltage. (220–230–240 V +10%) 2. Overload operation of refrigeration cycle Check installation condition (Short-circuit of outdoor diffuser).
		08	4-way valve inverse error (TC sensor value lowered during heating operation.)	Operation continues	—	1. Check 4-way valve operation.

11-5. Judgment of Trouble by Every Symptom

11-5-1. Indoor Unit (Including Remote Controller)

(1) Power is not turned on (Does not operate entirely)

<Primary check>

1. Is the supply voltage normal?
2. Is the normal voltage provided to the outdoor unit?
3. Is the crossover cable connected properly?
4. Is the fuse (F01) blown?

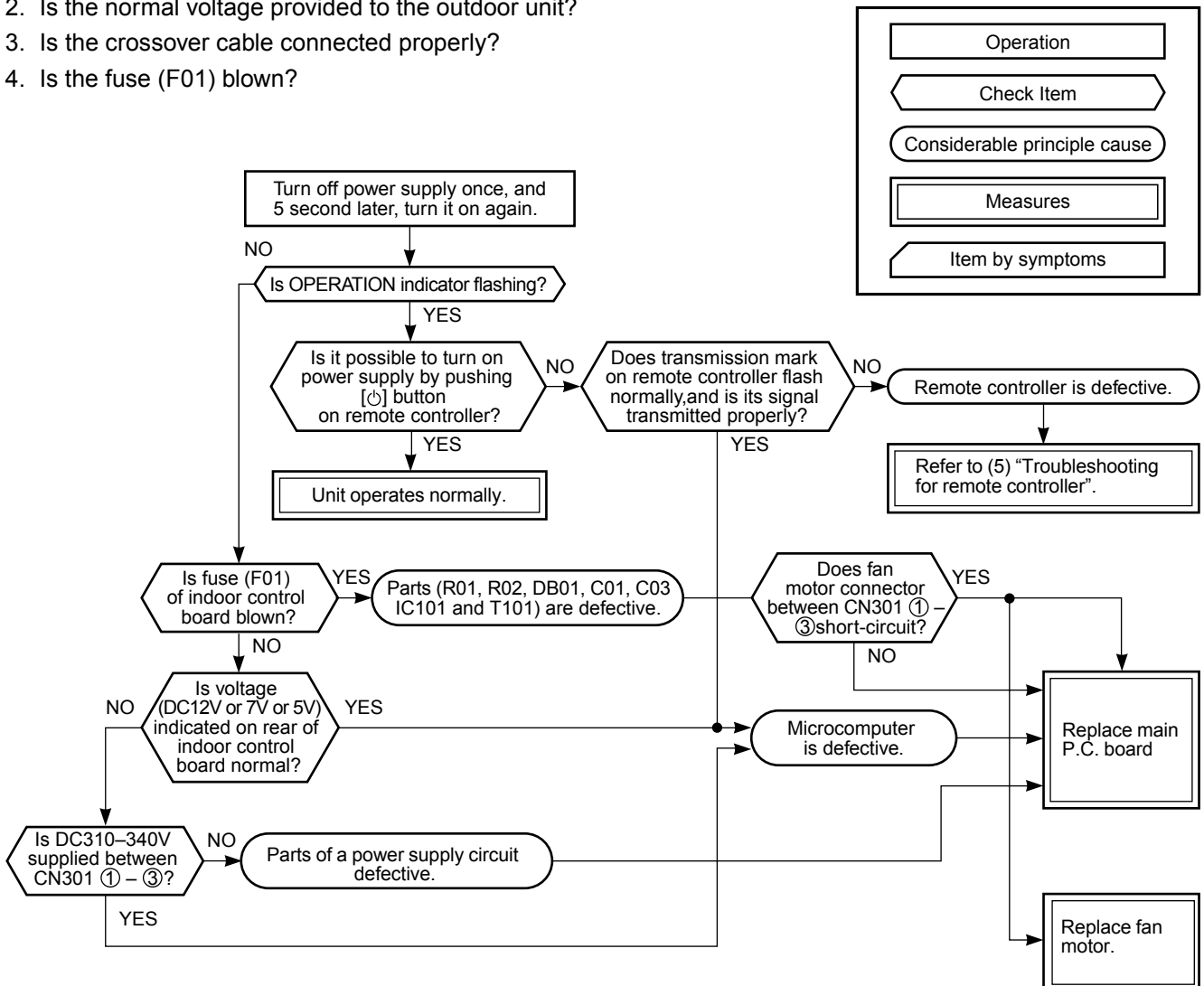

- Be sure to disconnect the motor connector CN301 after shut off the power supply, or it will be a cause of damage of the motor.

(2) Power is not turned on though Indoor P.C. board is replaced

<Confirmation procedure>

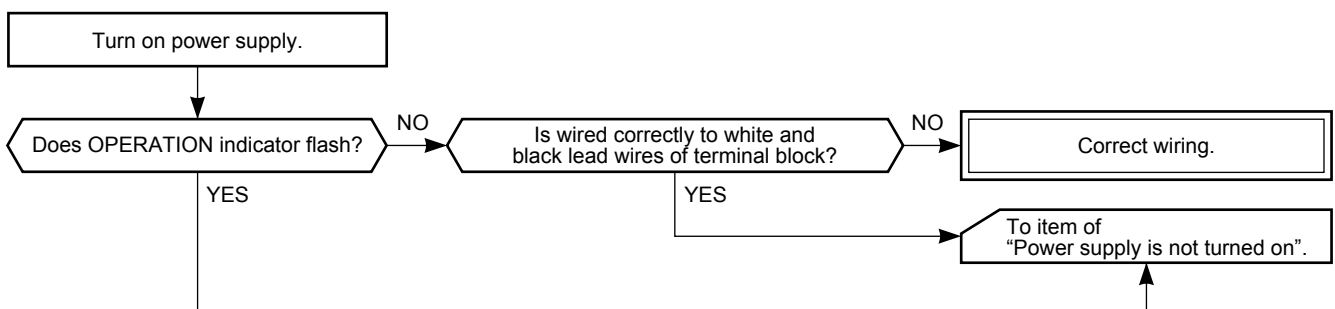

(3) Only the indoor motor fan does not operate

<Primary check>

1. Is it possible to detect the power supply voltage (AC220–240V) between ① and ② on the terminal block?
2. Does the indoor fan motor operate in cooling operation?
(In heating operation, the indoor fan motor does not operate for approximately 10 minutes after it is turned on, to prevent a cold air from blowing in.)

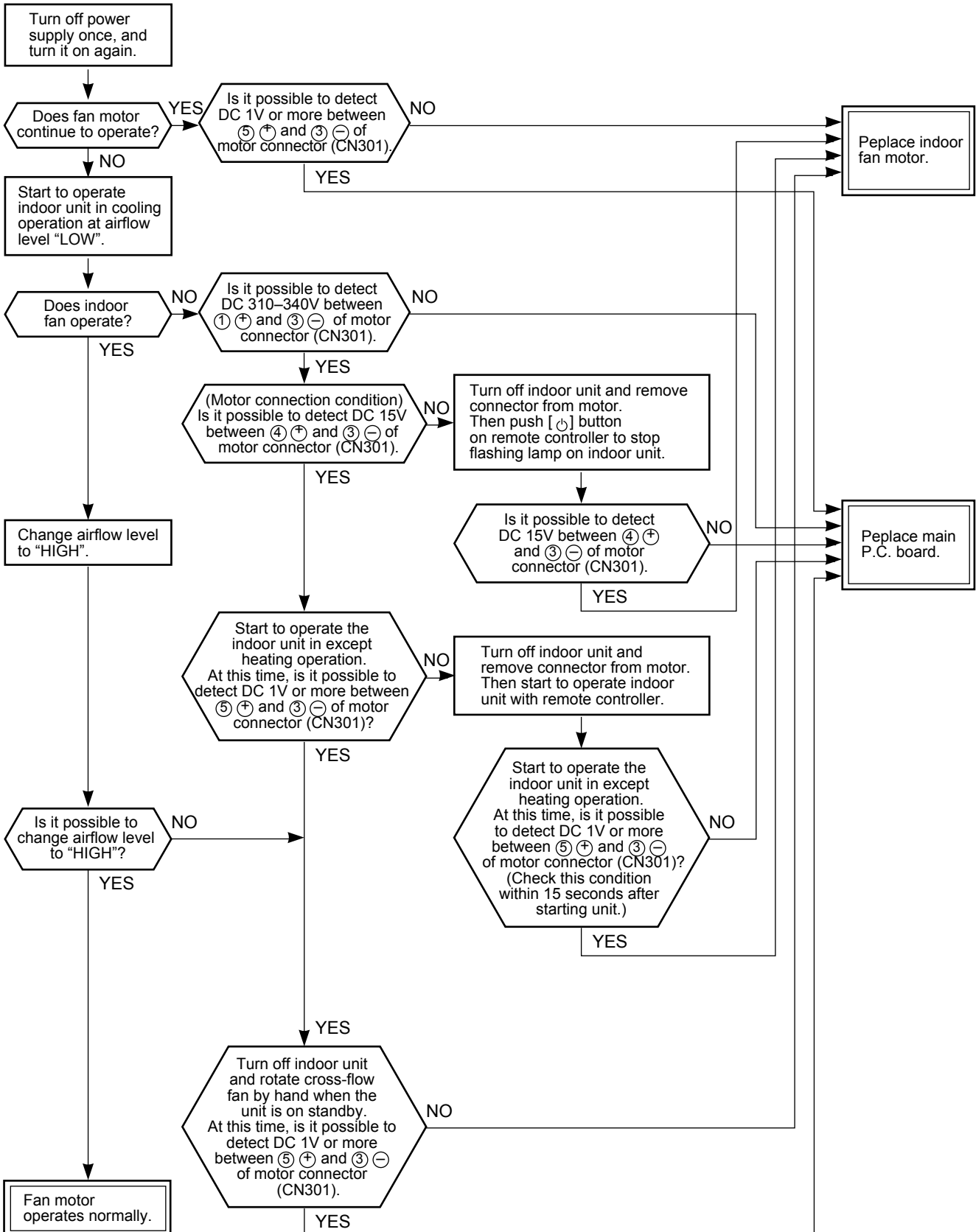

(4) Indoor fan motor automatically starts to rotate by turning on power supply

<Cause>

The IC is built in the indoor fan motor. Therefore the P.C. board is also mounted to inside of the motor.

If the P.C. board is soldered imperfectly or the IC is defective, the fan motor may automatically rotate by turning on power supply.

<Inspection procedure>

1. Remove the front panel. (Remove 4 screws.)
2. Remove the cover of the indoor unit controller. (remove 1 screw.)
3. Check DC voltage with CN301 connector while the fan motor is rotating.

NOTE :

- Do not disconnect the connector while the fan motor is rotating.
- Use a thin test rod.

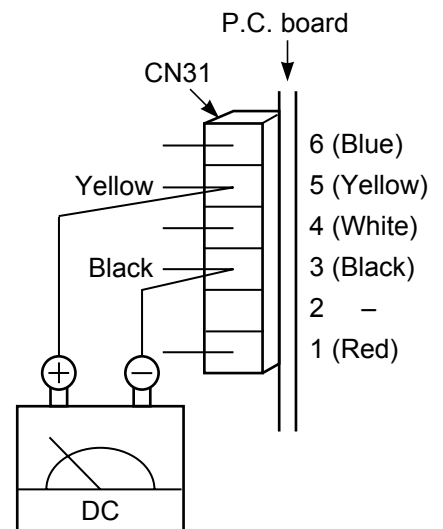
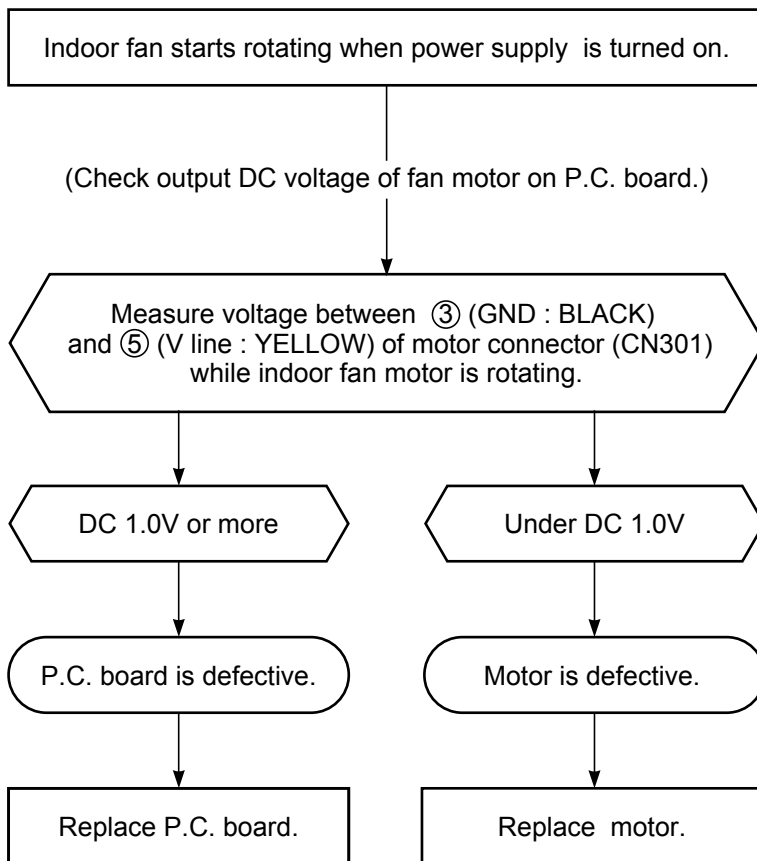

(5) Troubleshooting for remote control

<Primary check>

Check that A or B selected on the main unit is matched with A or B selected on the remote control.

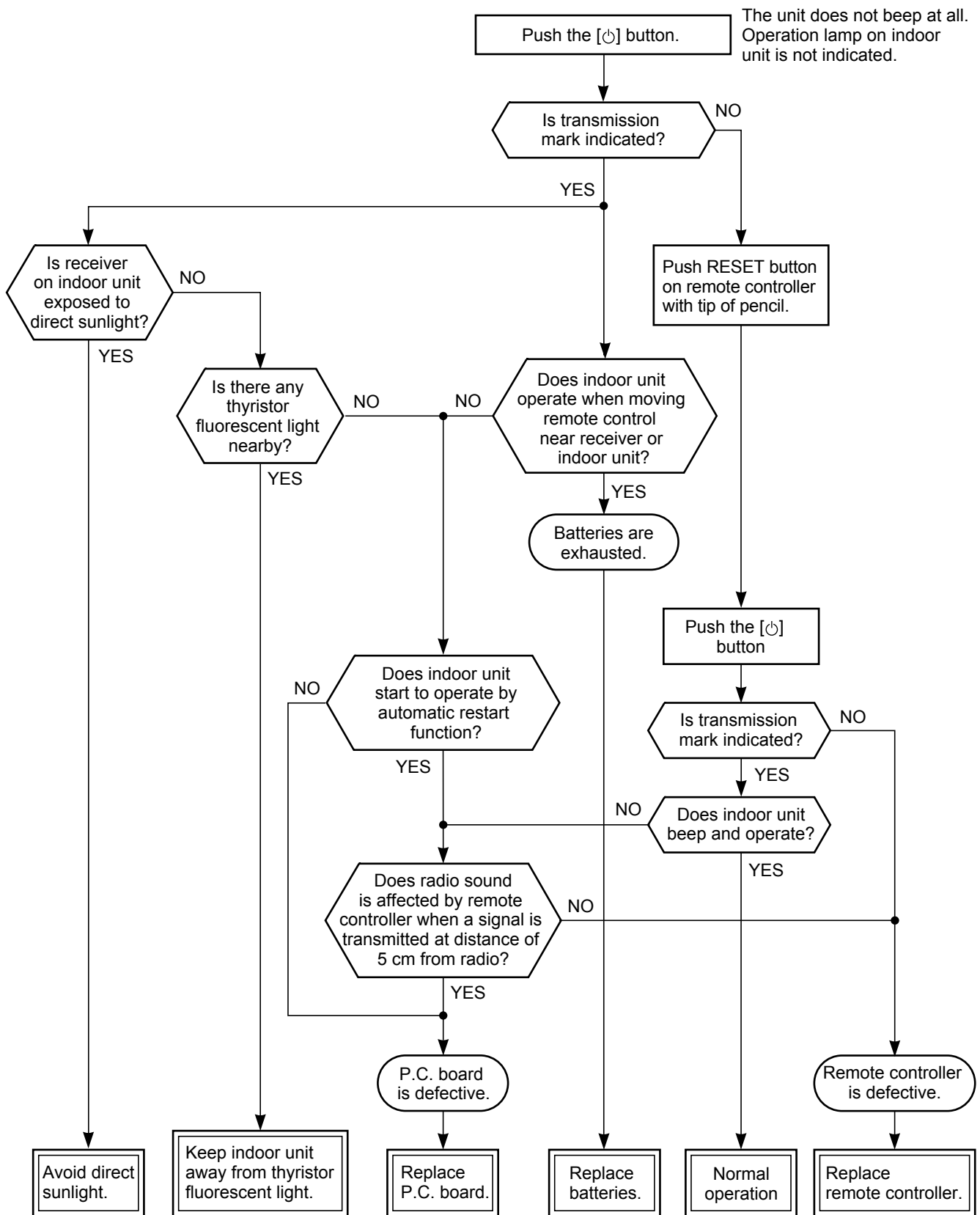

NOTE : After replacing batteries, push the RESET button with a tip of a pencil.

11-5-2. Wiring Failure (Interconnecting and Serial Signal Wire)

(1) Outdoor unit does not operate

- 1) Is the voltage between ② and ③ of the indoor terminal block varied?

Confirm that transmission from indoor unit to outdoor unit is correctly performed based upon the following diagram.

NOTE:

- Measurement should be performed 2 minutes and 30 seconds after starting of the operation.
- Be sure to prepare a diode for judgment.

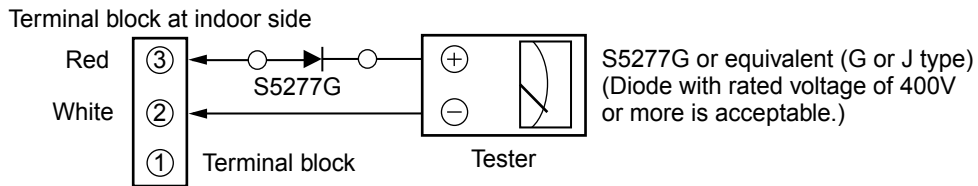

Normal time : Voltage swings between DC15 and 60V. Inverter Assembly check (11-7-1.)

Abnormal time : Voltage does not vary.

(2) Outdoor unit stops in a little while after operation started

<Check procedure> Select phenomena described below.

- 1) The outdoor unit stops 10 to 20 minutes after operation started, and 10 minutes or more are required to restart the unit.

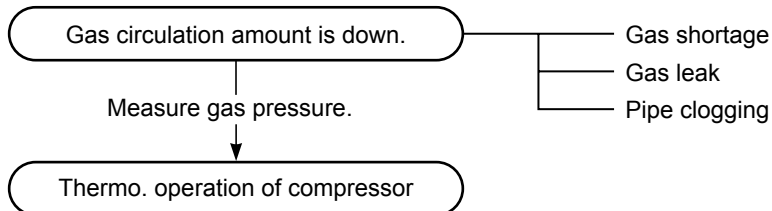

- 2) If the unit stops once, it does not operate until the power will be turned on again.

To item of Outdoor unit does not operate.

- 3) The outdoor unit stops 10 minutes to 1 hour after operation started, and an alarm is displayed. (Discharge temp. error check code 03, 1E Sensor temp. error check code 02, 1C)

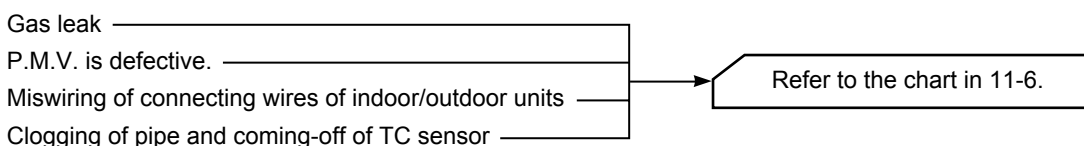

11-6. Check Code 1C (Miswiring in indoor/outdoor units) and 1E

<Check procedure>

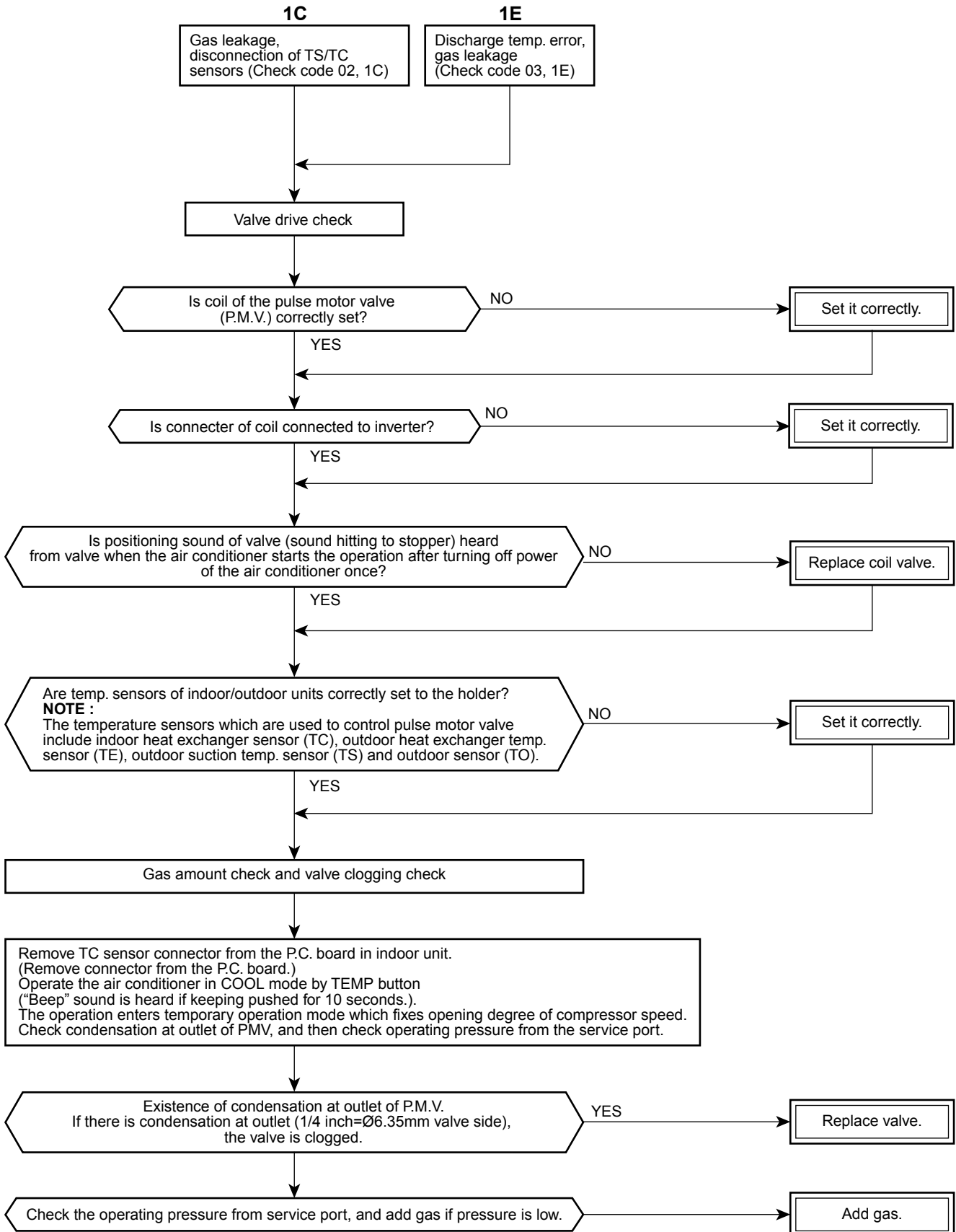

11-7. How to Diagnose Trouble in Outdoor Unit

11-7-1. Summarized Inner Diagnosis of Inverter Assembly

Table 11-7-1

Diagnosis/Process flowchart	Item	Contents	Summary		
<pre> graph TD A[Remove connector of compressor.] --> B{Check 25A fuse (Part No.F01).} B -- NG --> C[Replace fuse.] C --> D{Check electrolytic capacitor, diode block (DB01), etc.} B -- OK --> E{Check terminal voltage of electrolytic capacitor.} D -.-> E E -- NG --> F{Check electrolytic capacitor, diode (DB01), etc.} F -.-> E E -- OK --> G{Does outdoor fan rotate?} G -- YES --> H((A)) G -- NO --> I{Remove connector CN300 of outdoor fan motor, and using a tester, check resistance value between every phases at motor side.} I -- NG --> J[Replace outdoor fan motor.] I -- OK --> K((B)) </pre>	<p>Preparation</p> <p>Check</p> <p>Check</p> <p>Operation</p> <p>Measurement</p> <p>Check</p> <p>Stop</p> <p>Check Measurement</p>	<p>Turn "OFF" the power supply breaker, and remove 3P connector which connects inverter and compressor.</p> <ul style="list-style-type: none"> Check whether 25A fuse on the control board assembly is blown or not. (F01) <p>Turn on the power breaker, and operate the air conditioner in COOL mode by time shortening.</p> <p>Measure terminal voltage of the electrolytic capacity.</p> <table border="1" data-bbox="829 1545 1061 1624"> <tr> <td>500μF:400WV x 3</td> </tr> <tr> <td>760μF:400WV x 3</td> </tr> </table> <p>After operation, turn off the power breaker after 2 minutes 20 seconds passed, and discharge the electrolytic capacitor by soldering iron. Check voltage between motor phases.</p> <ul style="list-style-type: none"> Is not winding between ①-②, ②-③, or ①-③ opened or short-circuited? Is not frame grounded with ①, ②, or ③? 	500 μ F:400WV x 3	760 μ F:400WV x 3	<p>If fuse was blown, be sure to check the electrolytic capacitor and diode block. (DB01)</p> <ul style="list-style-type: none"> Connect discharge resistance (approx. 100. , 40W) or soldering iron (plug) between +, - terminals of the electrolytic capacitor (500μF or 760μF) of C14 (with printed CAUTION HIGH VOLTAGE) on P.C. board. <p>Discharging position (Discharging period 10 seconds or more)</p> <p>OK if 500μF or 760μF . DC280 to 380V</p> <p>Remove CN300 while pushing the part indicated by an arrow because CN300 is a connector with lock.</p> <p>Resistance between phases should be approx. 55 to 77.</p> <p>Should be 10M. or more.</p>
500 μ F:400WV x 3					
760 μ F:400WV x 3					

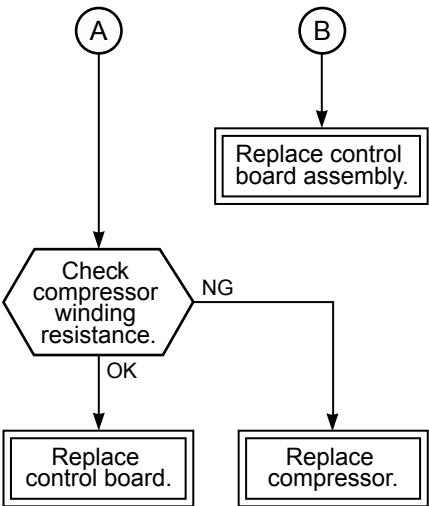
Diagnosis/Process flowchart	Item	Contents	Summary
 <pre> graph TD A((A)) --> Check{Check compressor winding resistance.} B((B)) --> ReplaceCB[Replace control board assembly.] Check -- OK --> ReplaceCB2[Replace control board.] Check -- NG --> ReplaceComp[Replace compressor.] </pre>	<p>Check</p> <p>Operation</p>	<p>Check winding resistance between phases of compressor, and resistance between outdoor frames by using a tester.</p> <ul style="list-style-type: none"> • Is not grounded. • Is not short-circuited between windings. • Winding is not opened. <p>Remove connector CN300 of the outdoor fan motor, turn on the power supply breaker, and perform the operation. (Stops though activation is prompted.)</p> <p>Check operation within 2 minutes 20 seconds after activation stopped.</p>	<p>OK if 10M. or more</p> <p>OK if 0.51. . 0.57. (Check by a digital tester.)</p>

11-9. How to Check Simply the Main Parts

11-9-1. How to Check the P.C. Board (Indoor Unit)

(1) Operating precautions

- 1) When removing the front panel or the P.C. board, be sure to shut off the power supply breaker.
- 2) When removing the P.C. board, hold the edge of the P.C. board and do not apply force to the parts.
- 3) When connecting or disconnecting the connectors on the P.C. board, hold the whole housing. Do not pull at the lead wire.

(2) Inspection procedures

- 1) When a P.C. board is judged to be defective, check for disconnection, burning, or discoloration of the copper foil pattern or this P.C. board.
- 2) The P.C. board consists of the following 2 parts

a. Main P.C. board part :

DC power supply circuit, Indoor fan motor control circuit, CPU and peripheral circuits, buzzer, and Driving circuit of louver.

b. Indication unit of infrared ray receiving infrared ray receiving circuit, LED :

To check defect of the P.C. board, follow the procedure described below.

(3) Check procedures

Table 11-9-1

			Causes
1	Turn off the power supply breaker and remove the P.C. board assembly from electronic parts base. Remove the connecting cables from the terminal block.	Check whether or not the fuse (F01) is blown.	Impulse voltage was applied or the indoor fan motor short-circuited.
2	Remove the connector of the motor and turn on the power supply breaker. If OPERATION indicator flashes (once per second), it is not necessary to check steps (1 to 3) in the right next column.	Check power supply voltage : 1. Between CN01 and No. 3 of CN301 (AC 220–240V) 2. Between ⊕ and ⊖ of C03 (DC 310–340V) 3. Between ⊖ of IC122 and output side of IC122 (DC15V) 4. Between 12V and GND 5. Between 5V and GND	1. The terminal block or the crossover cable is connected wrongly. 2. The fuse (F01), line filter (L01), resistor (R02), of the diode (DB01) is defective. 3. TC122 and T101 are defective. 4. D122, TC124 and T101 are defective 5. IC121, IC124, IC102, D121 and T101 are defective.
3	Push [⏻] button once to start the unit. (Do not set the mode to On-Timer operation.)	Check power supply voltage : 1. Between CN01 and CN501 (DC 15–60V)	IC501 and IC502 are defective.
4	Shorten the restart delay timer and start unit.	Check whether or not all indicators (OPERATION, TIMER, FILTER) are lit for 3 seconds and they return to normal 3 seconds later.	The indicators are defective or the housing assembly (CN51) display PCB is defective.
5	Push [⏻] button once to start the unit, • Shorten the restart delay timer. • Set the operation mode to COOL. • Set the fan speed level to AUTO. • Set the preset temperature much lower than the room temperature. (The unit (compressor) operates continuously in the above condition.)	1. Check whether or not the compressor operates. 2. Check whether or not the OPERATION indicator flashes.	1. The temperature of the indoor heat exchanger is extremely low. 2. The connection of the heat exchanger sensor is loose. (The connector is disconnected.) (CN602 and CN603) 3. The heat exchanger sensor and the P.C. board are defective. (Refer to Table 11-4-1.) 4. The main P.C. board is defective.
6	If the above condition (No. 5) still continues, start the unit in the following condition. • Set the operation mode to HEAT. • Set the preset temperature much higher than room temperature.	1. Check whether or not the compressor operates. 2. Check whether or not the OPERATION indicator flashes.	1. The temperature of the indoor heat exchanger is extremely high. 2. The connection of the heat exchanger sensor short-circuited. (CN602 and CN603) 3. The heat exchanger sensor and the P.C. board are defective. (Refer to Table 11-4-1.) 4. The main P.C. board is defective
7	Connect the motor connector to the motor and turn on the power supply. Start the unit the following condition. • Set the fan speed level to HIGH. (The unit (compressor) operates continuously in the above condition in No. 5.)	1. Check it is impossible to detect the voltage (AC120V or higher voltage) between red and black lead of the motor. 2. The motor does not operate or the fan motor does not rotate with high speed. (But it is possible to receive the signal from the remote controller.) 3. The motor rotates but vibrates strongly.	1. The indoor fan motor is defective. (Protected operation of P.C. board.) 2. The P.C. board is defective. 3. The connection of the motor connector is loose.

11-9-2. P.C . Board Layout

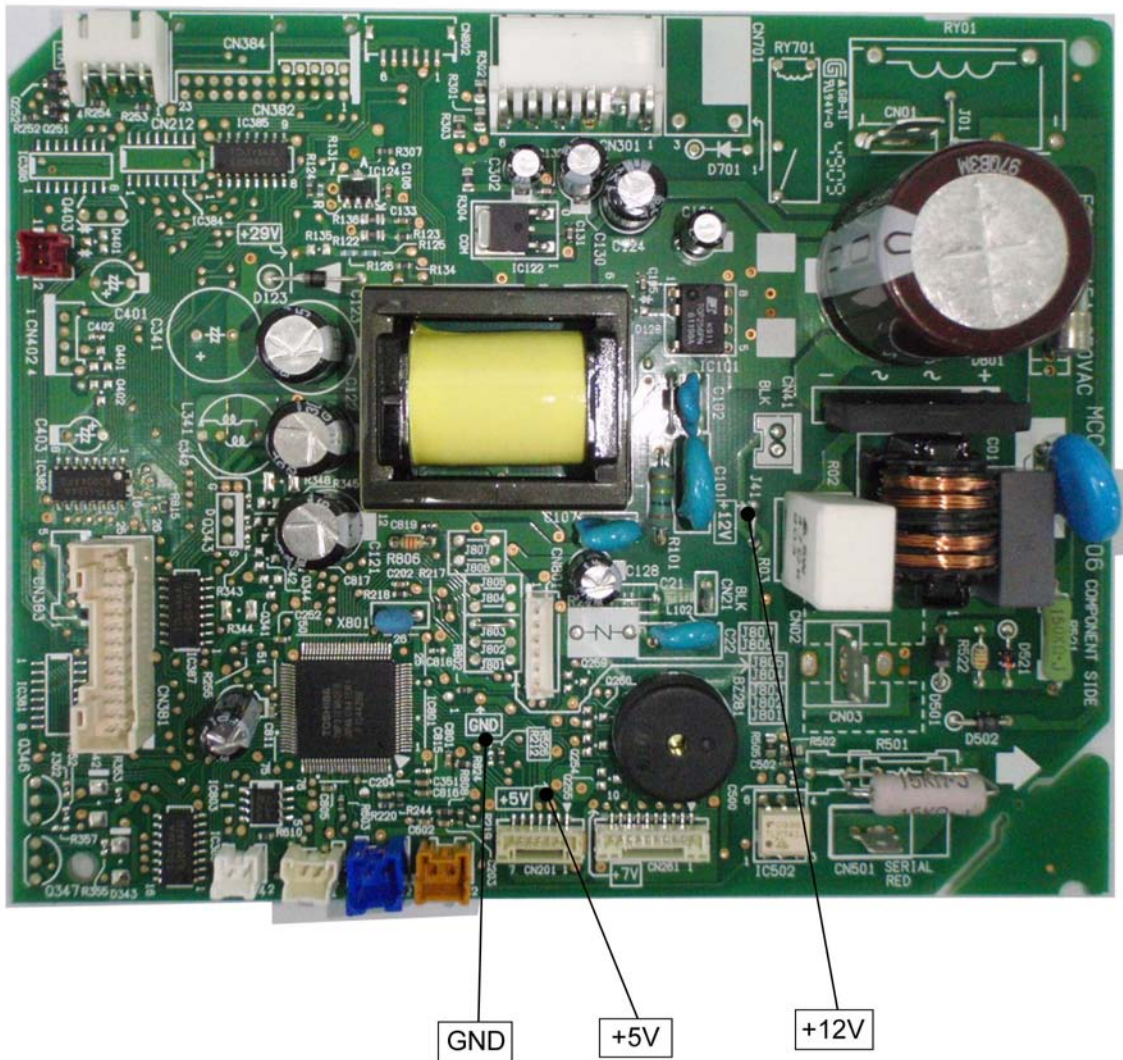

[1] Sensor characteristic table

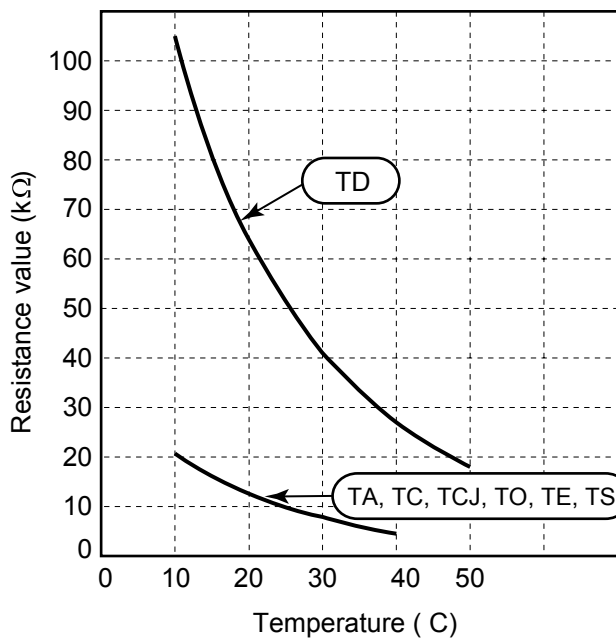

- TD : Discharge temp. sensor
- TA : Room temp. sensor
- TC, TCJ : Heat exchanger temp. sensor
- TO : Outdoor temp. sensor
- TE : Outdoor heat exchanger temp. sensor
- TS : Suction temp. sensor

11-9-3. Indoor Unit (Other Parts)

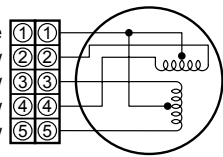
No.	Part name	Checking procedure																		
1	Room temp. (TA) sensor Heat exchanger (TC) sensor Heat exchanger (TCJ)sensor	Disconnect the connector and measure the resistance value with tester. (Normal temp.) <table border="1" style="margin-left: 20px;"> <thead> <tr> <th style="border: none;">Temperature</th> <th>10°C</th> <th>20°C</th> <th>25°C</th> <th>30°C</th> <th>40°C</th> </tr> </thead> <tbody> <tr> <th>Sensor</th> <td>20.7</td> <td>12.6</td> <td>10.0</td> <td>7.9</td> <td>4.5</td> </tr> <tr> <td colspan="6" style="text-align: center;">TA, TC, TCJ (k.)</td> </tr> </tbody> </table>	Temperature	10°C	20°C	25°C	30°C	40°C	Sensor	20.7	12.6	10.0	7.9	4.5	TA, TC, TCJ (k.)					
Temperature	10°C	20°C	25°C	30°C	40°C															
Sensor	20.7	12.6	10.0	7.9	4.5															
TA, TC, TCJ (k.)																				
2	Remote controller	Refer to 11-5-1. (5).																		
3	Louver motor & Damper motor MP24Z3T	Measure the resistance value of each winding coil by using the tester. (Under normal temp. 25°C) <div style="display: flex; align-items: center; margin-left: 20px;"> <div style="margin-right: 10px;"> White ①① Yellow ②② Yellow ③③ Yellow ④④ Yellow ⑤⑤ </div>  <table border="1" style="margin-left: 20px;"> <thead> <tr> <th>Position</th> <th>Resistance value</th> </tr> </thead> <tbody> <tr> <td>1 to 2</td> <td rowspan="4" style="text-align: center;">250 ± 20.</td> </tr> <tr> <td>1 to 3</td> </tr> <tr> <td>1 to 4</td> </tr> <tr> <td>1 to 5</td> </tr> </tbody> </table> </div>	Position	Resistance value	1 to 2	250 ± 20.	1 to 3	1 to 4	1 to 5											
Position	Resistance value																			
1 to 2	250 ± 20.																			
1 to 3																				
1 to 4																				
1 to 5																				
4	Indoor fan motor ICF-340-41-1	Refer to 11-5-1. (3) and (4).																		

11-9-4. OutdoorUnit

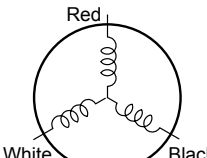
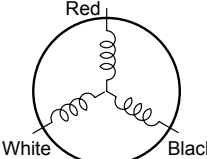
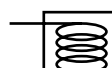
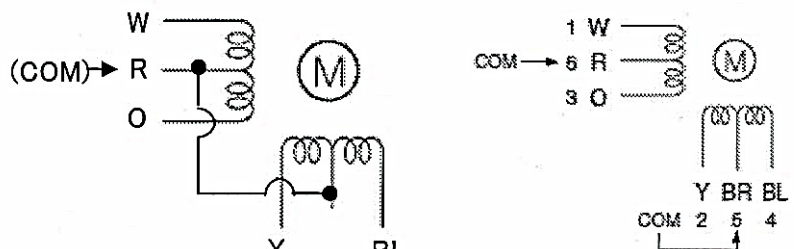
No.	Part name	Checking procedure																								
1	Compressor (Model : DA130A1F-27F) RAS-18SAV-E, RAS-18SAV2-E (Model : DA89X1C-23FZ2) RAS-10SAV2-E, RAS-13SAV2-E	Measure the resistance value of each winding by using the tester. <div style="display: flex; align-items: center; margin-left: 20px;">  <table border="1" style="margin-left: 20px;"> <thead> <tr> <th rowspan="2">Position</th> <th colspan="2">Resistance value</th> </tr> <tr> <th>DA130A1F-27F</th> <th>DA89X1C-1F-23FZ</th> </tr> </thead> <tbody> <tr> <td>Red - White</td> <td rowspan="3" style="text-align: center;">0.92 to 1.02Ω</td> <td rowspan="3" style="text-align: center;">1.04 to 1.16Ω</td> </tr> <tr> <td>White - Black</td> </tr> <tr> <td>Black - Red</td> </tr> </tbody> </table> </div> <p style="text-align: right; margin-right: 20px;">Under 20°C</p>	Position	Resistance value		DA130A1F-27F	DA89X1C-1F-23FZ	Red - White	0.92 to 1.02Ω	1.04 to 1.16Ω	White - Black	Black - Red														
Position	Resistance value																									
	DA130A1F-27F	DA89X1C-1F-23FZ																								
Red - White	0.92 to 1.02Ω	1.04 to 1.16Ω																								
White - Black																										
Black - Red																										
2	Outdoor fan motor (Model : ICF-140-43-4R)	Measure the resistance value of winding by using the tester. <div style="display: flex; align-items: center; margin-left: 20px;">  <table border="1" style="margin-left: 20px;"> <thead> <tr> <th>Position</th> <th>Resistance value</th> </tr> </thead> <tbody> <tr> <td>Red - White</td> <td>20 to 22.</td> </tr> <tr> <td>White - Black</td> <td>20 to 22.</td> </tr> <tr> <td>Black- Red</td> <td>20 to 22.</td> </tr> </tbody> </table> </div>	Position	Resistance value	Red - White	20 to 22.	White - Black	20 to 22.	Black- Red	20 to 22.																
Position	Resistance value																									
Red - White	20 to 22.																									
White - Black	20 to 22.																									
Black- Red	20 to 22.																									
3	4-way valve coil (Model : STF-01AJ646A1)	Measure the resistance value of winding by using the tester. <div style="display: flex; align-items: center; margin-left: 20px;">  <table border="1" style="margin-left: 20px;"> <thead> <tr> <th>Resistance value</th> </tr> </thead> <tbody> <tr> <td style="text-align: center;">1435 ± 144.</td> </tr> </tbody> </table> </div> <p style="text-align: right; margin-right: 20px;">Under 20°C</p>	Resistance value	1435 ± 144.																						
Resistance value																										
1435 ± 144.																										
4	Pulse motor valve coil (Model : CAM-MD12TF-16) or (Model : CAM-MD12TF-10) RAS-18SAV-E	Measure the resistance value of winding by using the tester. <div style="display: flex; justify-content: space-around; margin-left: 20px;"> <table border="1" style="font-size: small;"> <thead> <tr> <th colspan="2">CAM-MD12TF-16</th> </tr> <tr> <th>Position</th> <th>Resistance value</th> </tr> </thead> <tbody> <tr> <td>Red-White</td> <td>42 to 50Ω</td> </tr> <tr> <td>Red-Orange</td> <td>42 to 50Ω</td> </tr> <tr> <td>Red-Yellow</td> <td>42 to 50Ω</td> </tr> <tr> <td>Red-Blue</td> <td>42 to 50Ω</td> </tr> </tbody> </table> <table border="1" style="font-size: small;"> <thead> <tr> <th colspan="2">CAM-MD12TF-10</th> </tr> <tr> <th>Position</th> <th>Resistance value</th> </tr> </thead> <tbody> <tr> <td>Red-White</td> <td>42 to 50Ω</td> </tr> <tr> <td>Red-Orange</td> <td>42 to 50Ω</td> </tr> <tr> <td>Brown-Yellow</td> <td>42 to 50Ω</td> </tr> <tr> <td>Brown-Blue</td> <td>42 to 50Ω</td> </tr> </tbody> </table> </div> <div style="margin-left: 20px; margin-top: 10px;">  </div>	CAM-MD12TF-16		Position	Resistance value	Red-White	42 to 50Ω	Red-Orange	42 to 50Ω	Red-Yellow	42 to 50Ω	Red-Blue	42 to 50Ω	CAM-MD12TF-10		Position	Resistance value	Red-White	42 to 50Ω	Red-Orange	42 to 50Ω	Brown-Yellow	42 to 50Ω	Brown-Blue	42 to 50Ω
CAM-MD12TF-16																										
Position	Resistance value																									
Red-White	42 to 50Ω																									
Red-Orange	42 to 50Ω																									
Red-Yellow	42 to 50Ω																									
Red-Blue	42 to 50Ω																									
CAM-MD12TF-10																										
Position	Resistance value																									
Red-White	42 to 50Ω																									
Red-Orange	42 to 50Ω																									
Brown-Yellow	42 to 50Ω																									
Brown-Blue	42 to 50Ω																									

No.	Part name	Checking procedure																							
4	Pulse motor valve coil (Model : CAM-MD12TCTH-2) RAS-13SAV2-E RAS-10SAV2-E	<table border="1"> <thead> <tr> <th colspan="2">CAM-MD12TCTH-2</th> </tr> <tr> <th>Position</th> <th>Resistance value</th> </tr> </thead> <tbody> <tr> <td>Gray-White</td> <td>43 to 49Ω</td> </tr> <tr> <td>Gray-Orange</td> <td>43 to 49Ω</td> </tr> <tr> <td>Red-Yellow</td> <td>43 to 49Ω</td> </tr> <tr> <td>Red-Blue</td> <td>43 to 49Ω</td> </tr> </tbody> </table>	CAM-MD12TCTH-2		Position	Resistance value	Gray-White	43 to 49Ω	Gray-Orange	43 to 49Ω	Red-Yellow	43 to 49Ω	Red-Blue	43 to 49Ω											
CAM-MD12TCTH-2																									
Position	Resistance value																								
Gray-White	43 to 49Ω																								
Gray-Orange	43 to 49Ω																								
Red-Yellow	43 to 49Ω																								
Red-Blue	43 to 49Ω																								
5	Outdoor temperature sensor (TO), discharge temperature sensor (TD), suction temperature sensor (TS), outdoor heat exchanger temperature sensor (TE)	<p>Disconnect the connector and measure the resistance value with tester. (Normal temp.)</p> <table border="1"> <thead> <tr> <th colspan="2">Temperature</th> <th>10°C</th> <th>20°C</th> <th>25°C</th> <th>30°C</th> <th>40°C</th> <th>50°C</th> </tr> </thead> <tbody> <tr> <td rowspan="2">Sensor</td> <td>TD (kΩ)</td> <td>100</td> <td>64</td> <td>50</td> <td>41</td> <td>27</td> <td>18</td> </tr> <tr> <td>TO,TS,TE (kΩ)</td> <td>20.7</td> <td>12.6</td> <td>10.0</td> <td>7.9</td> <td>4.5</td> <td>—</td> </tr> </tbody> </table>	Temperature		10°C	20°C	25°C	30°C	40°C	50°C	Sensor	TD (kΩ)	100	64	50	41	27	18	TO,TS,TE (kΩ)	20.7	12.6	10.0	7.9	4.5	—
Temperature		10°C	20°C	25°C	30°C	40°C	50°C																		
Sensor	TD (kΩ)	100	64	50	41	27	18																		
	TO,TS,TE (kΩ)	20.7	12.6	10.0	7.9	4.5	—																		

11-9-5. Checking Method for Each Part

No.	Part name	Checking procedure												
1	Electrolytic capacitor (For boost, smoothing)	<ol style="list-style-type: none"> Turn OFF the power supply breaker. Discharge all three capacitors completely. Check that safety valve at the bottom of capacitor is not broken. Check that vessel is not swollen or exploded. Check that electrolytic liquid does not blow off. Check that the normal charging characteristics are shown in continuity test by the tester. <div style="border: 1px solid black; padding: 5px; margin-top: 10px;"> <p style="text-align: center;">Case that product is good</p> <p>Pointer swings once, and returns slowly. When performing test once again under another polarity, the pointer should return.</p> </div> <p>C12, C13, C14 . 500μF or 760μF/400V</p>												
2	Diode block	<ol style="list-style-type: none"> Turn OFF the power supply breaker. Completely discharge the four electrolytic capacitors. Remove the diode block from the PCB (which is soldered in place). Use a multimeter with a pointer to test the continuity, and check that the diode block has the proper rectification characteristics. <table border="1" style="margin-top: 10px;"> <thead> <tr> <th colspan="2">Tester rod</th> <th rowspan="2">Resistance value in good product</th> </tr> <tr> <th>+</th> <th>-</th> </tr> </thead> <tbody> <tr> <td>~ 2</td> <td rowspan="2">+ 1</td> <td rowspan="4" style="text-align: center; vertical-align: middle;">∞</td> </tr> <tr> <td>~ 3</td> </tr> <tr> <td rowspan="2">- 4</td> <td>~ 2</td> </tr> <tr> <td>~ 3</td> </tr> </tbody> </table> <p>10 to 20 . when the multimeter probe is reversed</p>	Tester rod		Resistance value in good product	+	-	~ 2	+ 1	∞	~ 3	- 4	~ 2	~ 3
Tester rod		Resistance value in good product												
+	-													
~ 2	+ 1	∞												
~ 3														
- 4	~ 2													
	~ 3													

11-10. How to Simply Judge Whether Outdoor Fan Motor is Good or Bad

1. Symptom

- Outdoor fan motor does not rotate.
 - Outdoor fan motor stops within several tens seconds though it started rotating.
 - Outdoor fan motor rotates or does not rotate according to the position where the fan stopped, etc.
- Remote controller check code “02 : Outdoor block, 1A : Outdoor fan drive system error”

2. Cause

The following causes are considered when the outdoor fan motor does not normally rotate.

- 1) Mechanical lock of the outdoor fan motor
- 2) Winding failure of the outdoor fan motor
- 3) Position-detect circuit failure inside of the outdoor fan motor
- 4) Motor drive circuit failure of the outdoor P.C. board

3. How to simply judge whether outdoor fan motor is good or bad

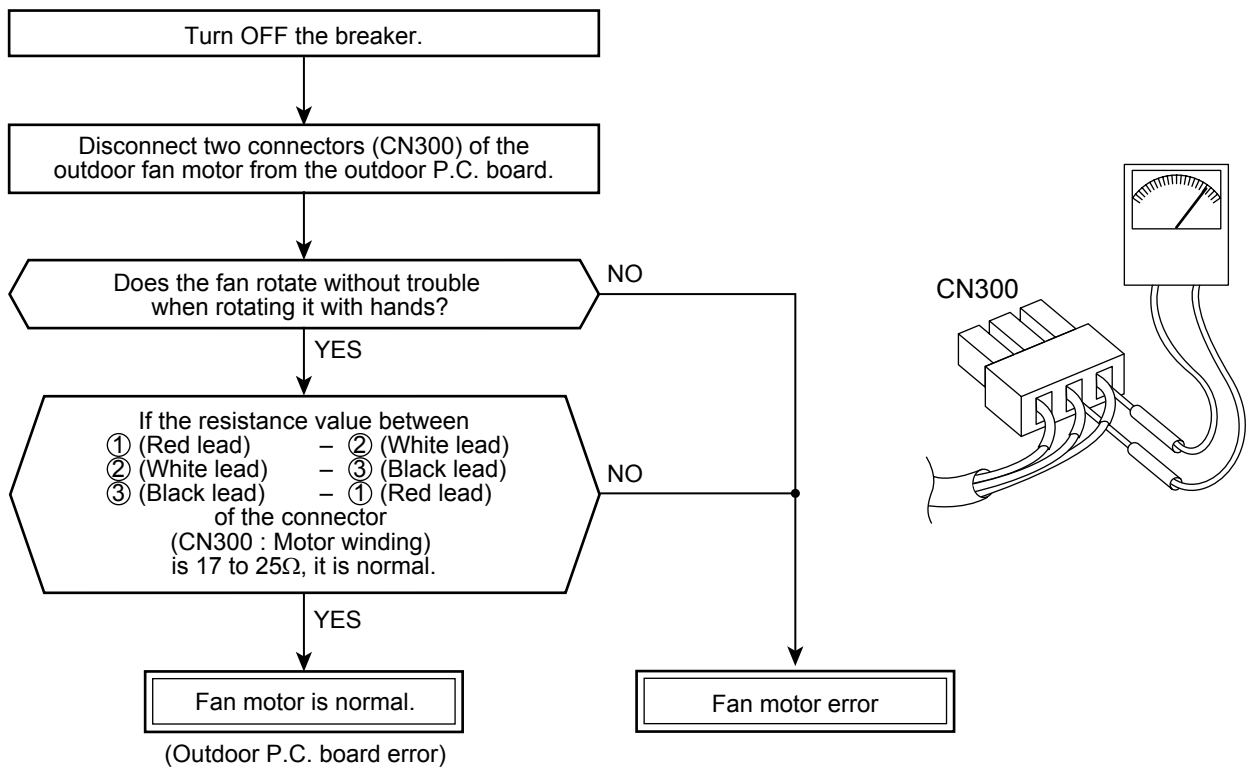

NOTE :

However, GND circuit error inside of the motor may be accepted in some cases when the above check is performed.

When the fan motor does not become normal even if P.C. board is replaced, replace the outdoor fan motor.

12. HOW TO REPLACE THE MAIN PARTS

WARNING

- Since high voltages pass through the electrical parts, turn off the power without fail before proceeding with the repairs.

Electric shocks may occur if the power plug is not disconnected.

- After the repairs have been completed (after the front panel and cabinet have been installed), perform a test run, and check for smoking, unusual sounds and other abnormalities.

If this check is omitted, a fire and/or electric shocks may occur.

Before proceeding with the test run, install the front panel and cabinet.

- Ensure that the following steps are taken when doing repairs on the refrigerating cycle.

1. Do not allow any naked flames in the surrounding area.

If a gas stove or other appliance is being used, extinguish the flames before proceeding.

If the flames are not extinguished, they may ignite any oil mixed with the refrigerant gas.

2. Do not use welding equipment in an airtight room.

Carbon monoxide poisoning may result if the room is not properly ventilated.

3. Do not bring welding equipment near flammable objects.

Flames from the equipment may cause the flammable objects to catch fire.



- **If keeping the power on is absolutely unavoidable while doing a job such as inspecting the circuitry, wear rubber gloves to avoid contact with the live parts.**



Electric shocks may be received if the live parts are touched.

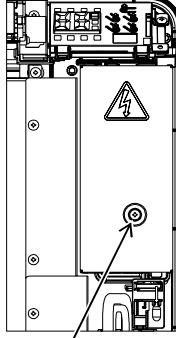
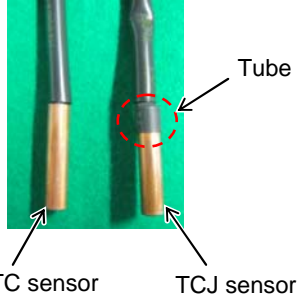
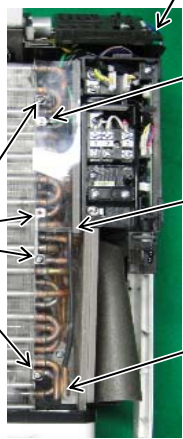
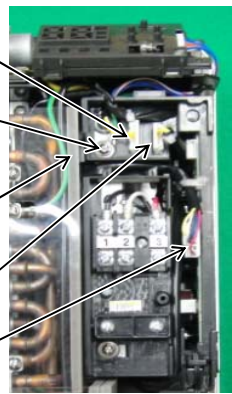
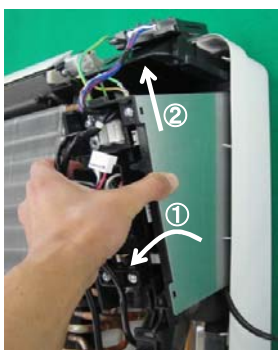

High-voltage circuits are contained inside this unit.



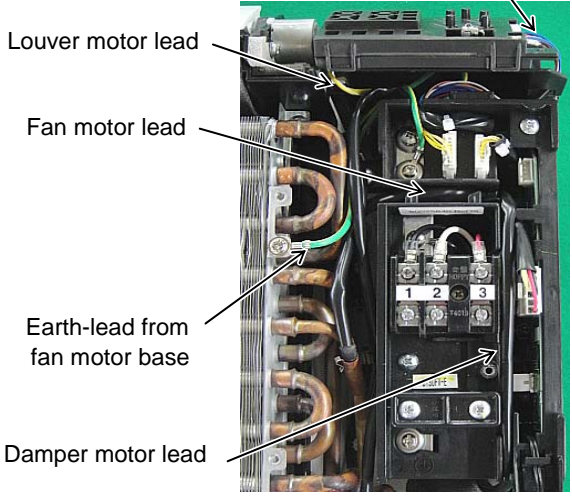
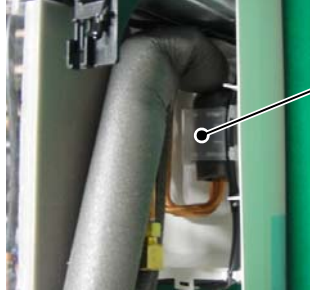
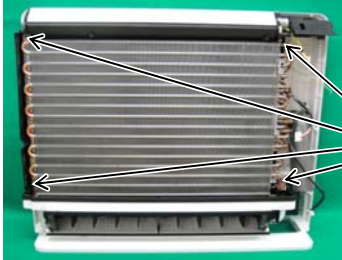
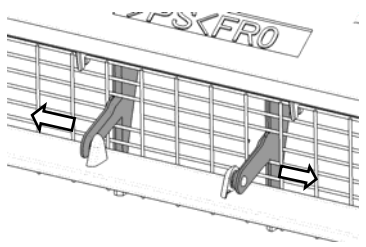

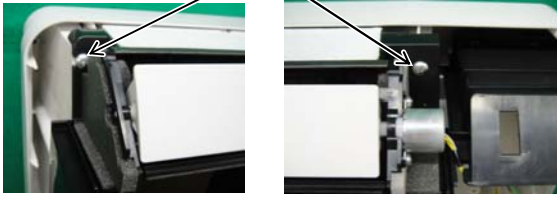
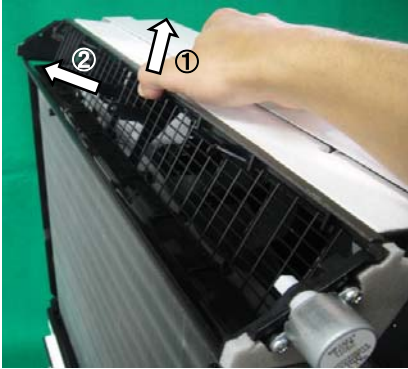

Proceed very carefully when conducting checks since directly touching the parts on the control circuit board may result in electric shocks.

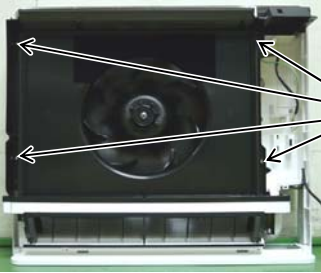
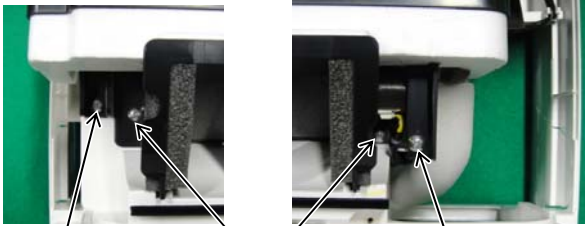

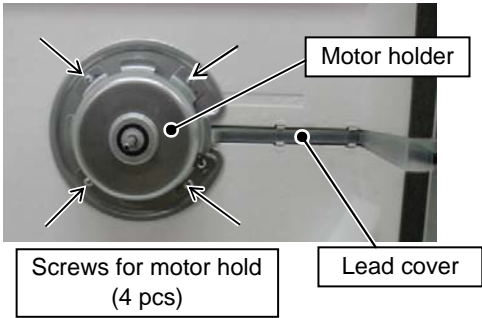
No.	Part name	Procedure	Remarks
①	Front panel	<p>1) Stop operation of the air conditioner and turn off the main power supply.</p> <p>2) Grip the air inlet grille by two hands at the handle positions.</p> <p>3) Pull the air inlet grille as the arrow direction and remove the rope from the hook of front panel.</p> <p>4) Remove screws for front panel. (4 pcs)</p>	<p>Air inlet grille</p> <p>Hook of front panel</p> <p>Rope</p> <p>4) Screws of front panel (4 pcs)</p>

No.	Part name	Procedure	Remarks
②	Electrical parts Box assembly (E-box)	<p>1) Remove screw for E-box cover.</p> <p>2) Remove screw for drain guide. (4 pcs)</p> <p>3) Remove screw for earth-lead.</p> <p>4) Remove screw for display base.</p> <p>5) Pull off the TC, TCJ sensor.</p> <p>6) Take off fan motor connector.</p> <p>7) Take off louver motor connector.</p> <p>8) Take off damper motor connector.</p> <p>9) Remove screw for earth-lead from fan motor base.</p> <p>10) Remove screw for E-box</p> <p>11) - ① Pull the upper part of the E-box.</p> <p>11) - ② Lift a E-box in the upward for take off from the hook.</p>	  <p>1) Screw for E-box cover</p> <p>4) The screw for display base</p>  <p>2) Screws for drain guide (4 pcs)</p> <p>3) Screw for earth-lead</p> <p>5) TCJ sensor</p> <p>5) TC sensor</p>  <p>7) Louver motor connector</p> <p>9) Screw for earth-lead from fan motor base</p> <p>10) Screw for E-box</p> <p>8) Damper motor connector</p> <p>6) Fan motor connector</p>   <p>Hook for locking E-box</p>

No.	Part name	Procedure	Remarks
②	Electrical parts Box assembly (E-box)	<How to arrange the lead> Shown in the picture.	 <p>Display unit lead</p> <p>Louver motor lead</p> <p>Fan motor lead</p> <p>Earth-lead from fan motor base</p> <p>Damper motor lead</p>
③	Heat exchanger (Refrigerant cycle assembly)	<p>1) Take off the pipe holder.</p> <p>2) Remove screws for heat exchanger. (4 pcs)</p>	 <p>Pipe holder</p>  <p>Screws for heat exchanger (4 pcs)</p>
④	Horizontal 1) louver	Open a horizontal louver outward and stretch the arm of louver base same as the direction in the picture.	 

No.	Part name	Procedure	Remarks
⑤	Louver base assembly	<p>1) Remove screws for louver base. (2 pcs)</p> <p>2) - ① Pull the upper part of the louver base to upward.</p> <p>2) - ② Take off the louver base by pull out in the front direction.</p> <p><Attention for louver base assemble> Insert the rib of the louver base into the slot of back body same as the picture.</p>	<p>Screws for louver base (2 pcs)</p>    <p>Back body slot</p> <p>Louver base rib</p>
⑥	Bell mouth	1) Remove screws for bell mouth. (4 pcs)	 <p>Screws for bell mouth (4 pcs)</p>
⑦	Drain pan and damper base	<p>1) Remove screws for drain pan. (2 pcs)</p> <p>2) Remove screws for damper base. (2 pcs)</p>	 <p>Screws for damper base (2 pcs)</p> <p>Screw for drain pan</p> <p>Screw for drain pan</p>

No.	Part name	Procedure	Remarks
⑧	Turbo fan	<p>1) Turn the flange nut (M10) in the counter-clockwise direction and take it off.</p> <p>2) Pull out the turbo fan from the fan motor shaft.</p> <p><Attention for turbo fan assemble> The tightening torque of the flange nut is 5N·m.</p>	
⑨	Fan motor	<p>1) Remove screws for motor holder, and take off the motor holder.</p> <p>2) Take off the lead cover.</p> <p><Attention for motor holder assemble> 1. Arrange the earth lead and fan motor lead. 2. Adjust the motor axis to the center of the motor holder then fix screws 4 pcs.</p>	   
⑩	Fan motor	<p>A method to take off a fan motor in a condition taking on a heat exchanger.</p> <p>1) Take off pipe holder and remove screws for heat exchanger. (refer to ③)</p> <p>2) Remove screws for the bell mouth. (refer to ⑥)</p>	 

No.	Part name	Procedure	Remarks
⑩	Fan motor	<p>3) Remove the flange nut and turbo fan. (refer to ⑧)</p> <p>4) Remove screws for motor holder and lead cover. (refer to ⑨)</p>	  

12-2. Microcomputer

No.	Part name	Procedure	Remarks
①	Common procedure	1) Turn the power supply off to stop the operation of air-conditioner. 2) Remove the front panel. <ul style="list-style-type: none"> • Remove the 2 fixing screws. 3) Remove the electrical part base.	Replace terminal block, microcomputer ass'y and the P.C. board ass'y.

<P.C. board layout>

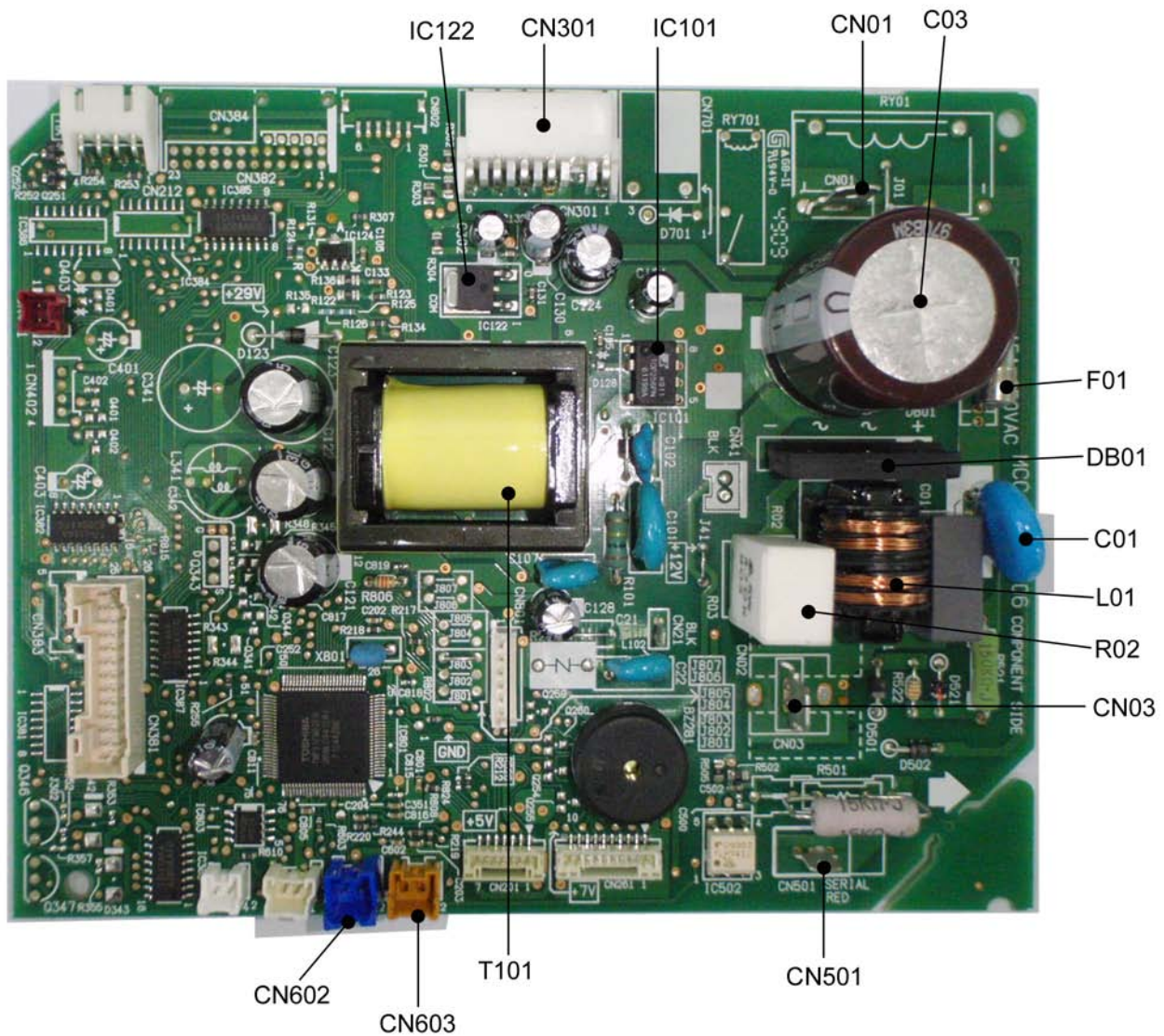

12-3. Outdoor Unit (RAS-10SAV2-E, RAS-13SAV2-E)

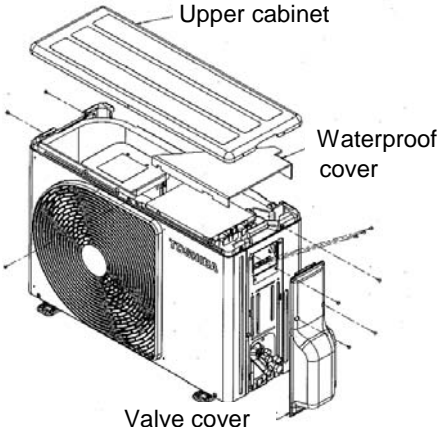
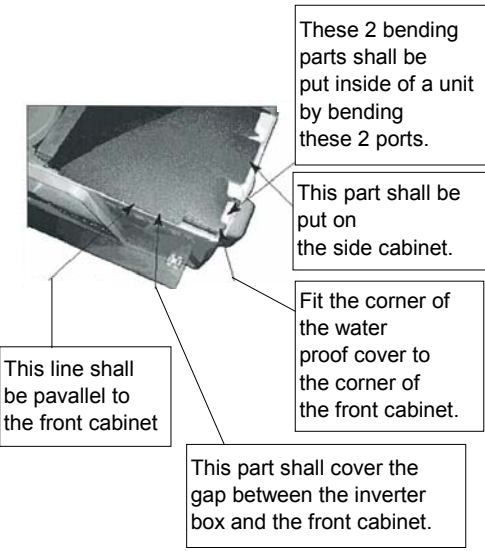
No.	Part name	Procedure	Remarks
①	Common procedure	<p>1. Detachment</p> <div style="border: 1px solid black; padding: 5px; margin: 10px 0;"> <p style="text-align: center;">NOTE</p> <p>Wear gloves for this job. Otherwise, you may injure your hands on the parts, etc.</p> </div> <ol style="list-style-type: none"> 1) Stop operation of the air conditioner, and turn off the main switch of the breaker for air conditioner. 2) Remove the valve cover. (ST1TØ4 × 10L 2 pcs.) <ul style="list-style-type: none"> • After removing screw, remove the valve cover pulling it downward. 3) Remove cord clamp (ST2TØ4 × 14L 3 pcs.), and then remove connecting cable. 4) Remove the upper cabinet. (ST1TØ4 × 10L 5 pcs.) <ul style="list-style-type: none"> • After removing screws, remove the upper cabinet pulling it upward. <p>2. Attachment</p> <ol style="list-style-type: none"> 1) Attach the water-proof cover. <div style="border: 1px solid black; padding: 5px; margin: 10px 0;"> <p style="text-align: center;">NOTE</p> <p>The water-proof cover must be attached without fail in order to prevent rain water, etc. from entering inside the indoor unit.</p> </div> <ol style="list-style-type: none"> 2) Attach the upper cabinet. (ST1TØ4 × 10L 5 pcs.) 3) Perform cabling of connecting cable, and attach the cord clamp. <ul style="list-style-type: none"> • Fix the cord clamp by tightening the screws (ST2TØ 4 x 14L 3 pcs.), fitting 2 concave parts of the cord clamp to each connecting cables. 4) Attach the valve cover. (ST1TØ 4 x 10L 2 pcs.) <ul style="list-style-type: none"> • Insert the upper part into the square hole of the side cabinet, set hook claws of the valve cover to square holes (at three positions) of the main unit, and attach it pushing upward, 	 <p style="text-align: center;">Upper cabinet Waterproof cover Valve cover</p>  <div style="border: 1px solid black; padding: 2px; margin: 5px 0;"> <p>These 2 bending parts shall be put inside of a unit by bending these 2 ports.</p> </div> <div style="border: 1px solid black; padding: 2px; margin: 5px 0;"> <p>This part shall be put on the side cabinet.</p> </div> <div style="border: 1px solid black; padding: 2px; margin: 5px 0;"> <p>Fit the corner of the water proof cover to the corner of the front cabinet.</p> </div> <div style="border: 1px solid black; padding: 2px; margin: 5px 0;"> <p>This part shall cover the gap between the inverter box and the front cabinet.</p> </div> <div style="border: 1px solid black; padding: 2px; margin: 5px 0;"> <p>This line shall be pavalal to the front cabinet</p> </div> <div style="border: 1px solid black; padding: 5px; margin: 10px 0; text-align: center;"> <p>How to mount the water-proof cover</p> </div>

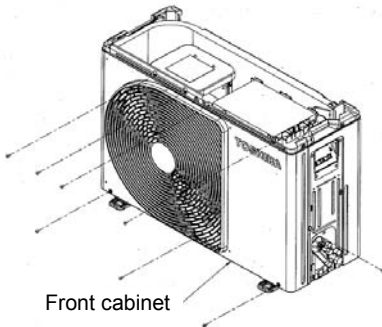
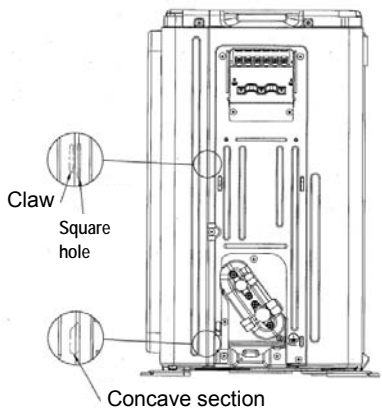
No.	Part name	Procedure	Remarks
②	Front cabinet	<p>1. Detachment</p> <ol style="list-style-type: none"> 1) Perform step 1 in ①. 2) Remove the fixing screws (ST1TØ4 × 10L 2 pcs.) used to secure the front cabinet and inverter cover, the screws (ST1TØ4 × 10L 4 pcs.) used to secure the front cabinet at the bottom, and the fixing screws (ST1TØ4 × 10L 2 pcs.) used to secure the motor base. <ul style="list-style-type: none"> • The front cabinet is fitted into the side cabinet (left) at the front left side so pull up the top of the front cabinet to remove it. <p>2. Attachment</p> <ol style="list-style-type: none"> 1) Insert the claw on the front left side into the side cabinet (left). 2) Hook the bottom part of the front right side onto the concave section of the bottom plate. Insert the claw of the side cabinet (right) into the square hole in the front cabinet. 3) Return the screws that were removed above to their original positions and attach them. 	 <p>Front cabinet</p>  <p>Claw Square hole Concave section</p>

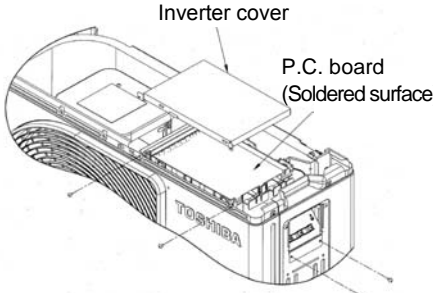
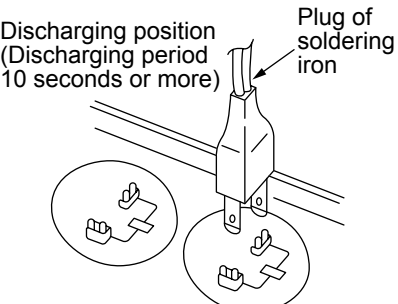
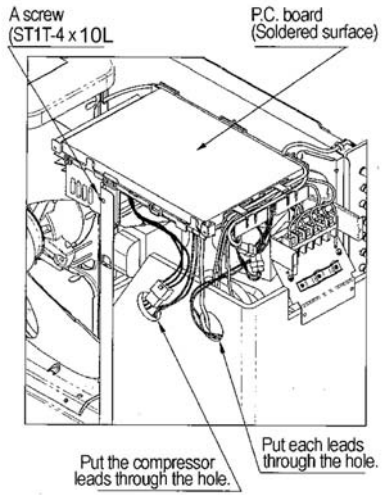
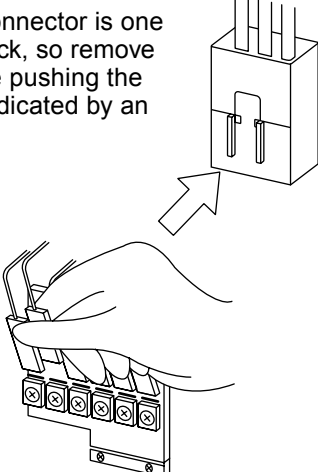
No.	Part name	Procedure	Remarks
③	Inverter assembly	<p>1) Perform work of item 1 in ①.</p> <p>2) Remove screw (ST1TØ4 × 10L 2 pcs.) of the upper part of the front cabinet.</p> <ul style="list-style-type: none"> • If removing the inverter cover in this condition, P.C. board can be checked. • If there is no space above the unit, perform work of 1 in ②. <div style="border: 1px solid black; padding: 5px; margin: 10px 0;"> <p>Be careful to check the inverter because high-voltage circuit is incorporated in it.</p> </div> <p>3) Perform discharging by connecting ⊕, ⊖ polarity by discharging resistance (approx. 100. 40W) or plug of soldering iron to ⊕, ⊖ terminals a of the C14 (printed “CAUTION HIGH VOLTAGE” is attached.) electrolytic capacitor (760µF or 500µF) on P.C. board.</p> <div style="border: 1px solid black; padding: 5px; margin: 10px 0;"> <p>Be careful to discharge the capacitor because the electrolytic capacitor cannot naturally discharge and voltage remains according to trouble type in some cases.</p> </div> <div style="text-align: center; margin: 10px 0;"> <p>NOTE</p> <p>This capacitor is one with mass capacity. Therefore, it is dangerous that a large spark generates if short-circuiting between ⊕, ⊖</p> </div> <p>4) Remove screw (ST1TØ4 x 10L 4pcs.) fixing the terminal part of inverter box to the main body.</p> <p>5) Remove the front cabinet by performing step 1 in ② , and remove the fixing screws (ST1TØ4 x 10L) for securing the main body and inverter box.</p> <p>6) Remove various lead wires from the holder at upper part of the inverter box.</p> <p>7) Pull the inverter box upward.</p> <p>8) Disconnect connectors of various lead wires.</p> <div style="border: 1px solid black; padding: 5px; margin: 10px 0;"> <p style="text-align: center;">Requirement</p> <p>As each connector has a lock mechanism, avoid to remove the connector by holding the lead wire, but by holding the connector.</p> </div>	 <p>Inverter cover P.C. board (Soldered surface)</p>  <p>Discharging position (Discharging period 10 seconds or more) Plug of soldering iron</p>  <p>A screw (ST1T-4 x 10L) P.C. board (Soldered surface)</p> <p>Put the compressor leads through the hole. Put each leads through the hole.</p>  <p>The connector is one with lock, so remove it while pushing the part indicated by an arrow.</p> <p>Be sure to remove the connector by holding the connector, not by pulling the lead wire.</p>

No.	Part name	Procedure	Remarks
④	Control board assembly	<p>1. Disconnect the leads and connectors connected to the other parts from the control board assembly.</p> <p>1) Leads</p> <ul style="list-style-type: none"> • 3 leads (black, white, orange) connected to terminal block. • Lead connected to compressor : Disconnect the connector (3P). • Lead connected to reactor : Disconnect the connector (2P). <p>2) Connectors (×7)</p> <p>CN300 : Outdoor fan motor (3P: white)* (* : See Note)</p> <p>CN701 : 4-way valve (2P: yellow)*</p> <p>CN600 : TE sensor (2P: white)*</p> <p>CN700 : PMV (6P: white)</p> <p>CN603 : TS sensor (3P: white)*</p> <p>CN601 : TD sensor (3P: white)*</p> <p>CN602 : TO sensor (2P: white)</p> <div data-bbox="424 898 1054 1043" style="border: 1px solid black; padding: 5px; margin: 10px 0;"> <p style="text-align: center;">NOTE</p> <p>These connectors have a disconnect prevention mechanism: as such, the lock on their housing must be released before they are disconnected.</p> </div> <p>2. Remove the control board assembly from the P.C. board base. (Remove the heat sink and control board assembly while keeping them screwed together.)</p> <div data-bbox="424 1211 1054 1335" style="border: 1px solid black; padding: 5px; margin: 10px 0;"> <p style="text-align: center;">NOTE</p> <p>Disengage the four claws of the P.C. board base, hold the heat sink, and lift to remove it.</p> </div> <p>3. Remove the two fixing screws used to secure the heat sink and control board assembly.</p> <p>4. Mount the new control board assembly.</p> <div data-bbox="424 1491 1054 1637" style="border: 1px solid black; padding: 5px; margin: 10px 0;"> <p style="text-align: center;">NOTE</p> <p>When mounting the new control board assembly, ensure that the P.C. board is inserted properly into the P.C. board support groove.</p> </div>	<div data-bbox="1106 315 1433 521" style="border: 1px solid black; padding: 5px; margin-bottom: 20px;"> </div> <p>CN300, CN701, CN600 and CN603 are connectors with locking mechanisms: as such, to disconnect them, they must be pressed in the direction of the arrow while pulling them out.</p> <div data-bbox="1198 891 1313 1081" style="text-align: center;"> </div> <div data-bbox="1219 1104 1278 1182" style="text-align: center;"> </div> <div data-bbox="1106 1223 1377 1346" style="text-align: center;"> <p>P.C. board base P.C. board</p> </div>

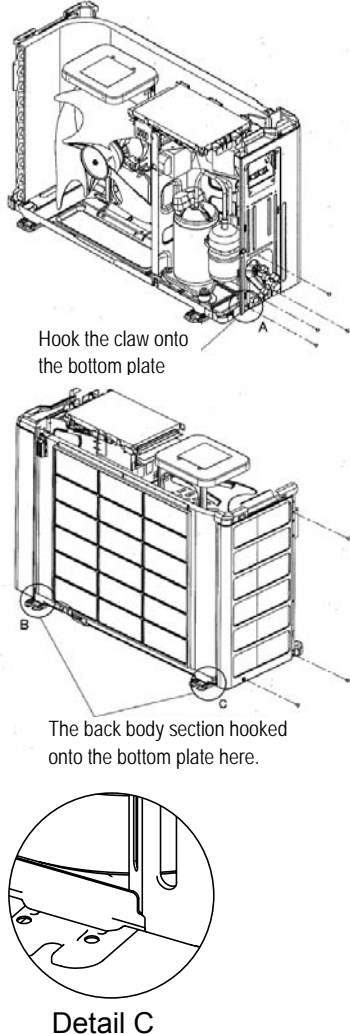
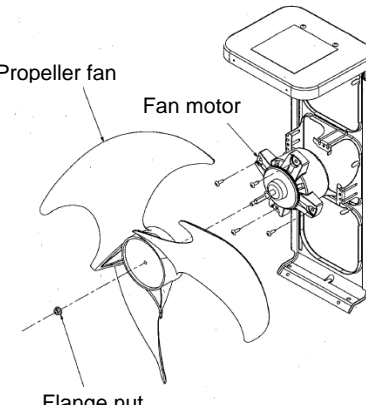
No.	Part name	Procedure	Remarks
⑤	Side cabinet	<p>1. Side cabinet (right)</p> <ol style="list-style-type: none"> 1) Perform step 1 in ② and all the steps in ③. 2) Remove the fixing screw (ST1TØ4 × 10L 4 pcs.) used for securing the side cabinet to the bottom plate and valve fixing panel. <p>2. Side cabinet (left)</p> <ol style="list-style-type: none"> 1) Perform step 1 in ②. 2) Remove the fixing screw (ST1TØ4 × 10L 1 pc.) used to secure the side cabinet (left) onto the heat exchanger. 3) Remove the fixing screw (ST1TØ4 × 10L 2 pcs.) used for securing the side cabinet to the bottom plate and heat exchanger. 	 <p>Hook the claw onto the bottom plate</p> <p>The back body section hooked onto the bottom plate here.</p> <p>Detail A Detail B Detail C</p>
⑥	Fan motor	<ol style="list-style-type: none"> 1) Perform work of item 1 of ① and ②. 2) Remove the flange nut fixing the fan motor and the propeller. <ul style="list-style-type: none"> • Flange nut is loosened by turning clockwise. (To tighten the flange nut, turn counterclockwise.) 3) Remove the propeller fan. 4) Disconnect the connector for fan motor from the inverter. 5) Remove the fixing screws (4 pcs.) holding by hands so that the fan motor does not fall. <p>* Precautions when assembling the fan motor Tighten the flange nut using a tightening torque of 4.9 N•m.</p>	 <p>Propeller fan</p> <p>Fan motor</p> <p>Flange nut</p>

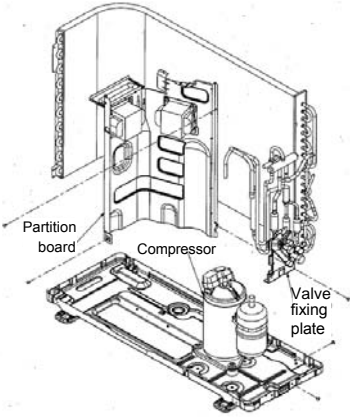
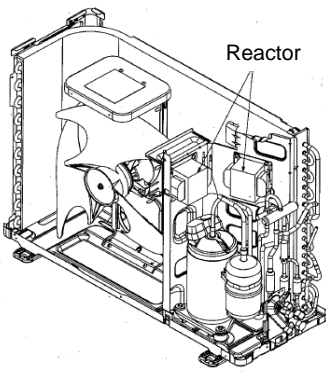
No.	Part name	Procedure	Remarks
⑦	Compressor	<ol style="list-style-type: none"> 1) Perform work of item 1 of ① and ②, ③, ④, ⑤. 2) Extract refrigerant gas. 3) Remove the partition board. (ST1TØ4 × 10L 3 pcs.) 4) Remove the sound-insulation material. 5) Remove terminal cover of the compressor, and disconnect lead wire of the compressor from the terminal. 6) Remove pipe connected to the compressor with a burner. <ul style="list-style-type: none"> • Take care to keep the 4-way valve away from naked flames. (Otherwise, it may malfunction.) 7) Remove the fixing screw of the bottom plate and heat exchanger. (ST1TØ4 × 10L 1 pc.) 8) Remove the fixing screw of the bottom plate and valve fixing plate. (ST1TØ4 × 10L 1 pc.) 9) Pull upward the refrigeration cycle. 10) Remove NUT (3 pcs.) fixing the compressor to the bottom plate. 	
⑧	Reactor	<ol style="list-style-type: none"> 1) Perform work of item 1 of ②, and ③. 2) Remove screws fixing the reactor. (ST1TØ4 × 10L 2 pcs.) 	

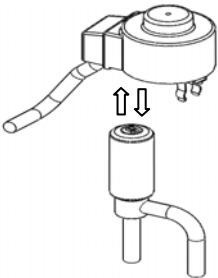
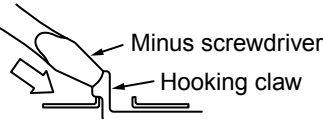
No.	Part name	Procedure	Remarks
⑨	Electronic expansion valve coil	<p>1. Detachment</p> <p>1) Perform step 1 in ②, all the steps in ③ and 1 in ⑤.</p> <p>2) Remove the coil by pull it upward.</p> <p>2. Attachment</p> <p>1) Insert a valve coil to value body by push it downward. And confirm to fix it surely.</p>	
⑩	Fan guard	<p>1. Detachment</p> <p>1) Perform work of item 1 of ②.</p> <p>2) Remove the front cabinet, and put it down so that fan guard side directs downward.</p> <div data-bbox="453 1093 1023 1189" style="border: 1px solid black; padding: 5px; margin: 10px 0;"> <p>Perform work on a corrugated cardboard, cloth, etc. to prevent flaw to the product.</p> </div> <p>3) Remove the hooking claws by pushing minus screwdriver according to the arrow mark in the right figure, and remove the fan guard.</p> <p>2. Attachment</p> <p>1) Insert claws of the fan guard in the holes of the front cabinet. Push the hooking claws (9 positions) by hands and fix the claws.</p> <div data-bbox="453 1547 1023 1644" style="border: 1px solid black; padding: 5px; margin: 10px 0;"> <p>Check that all the hooking claws are fixed to the specified positions.</p> </div>	

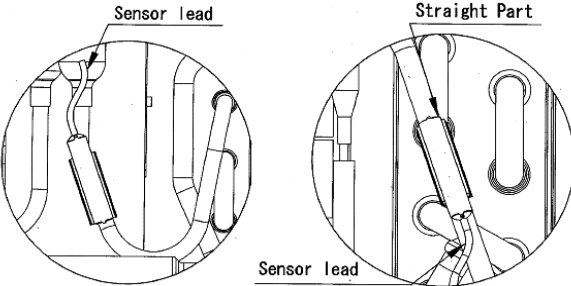
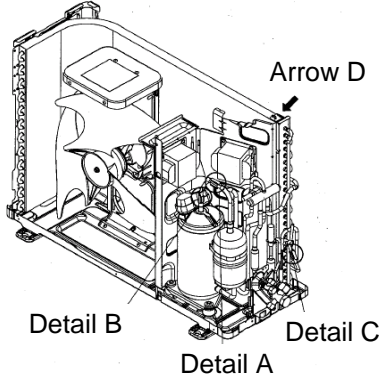
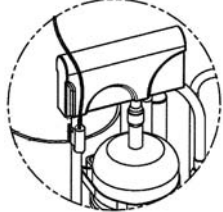
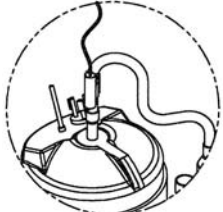
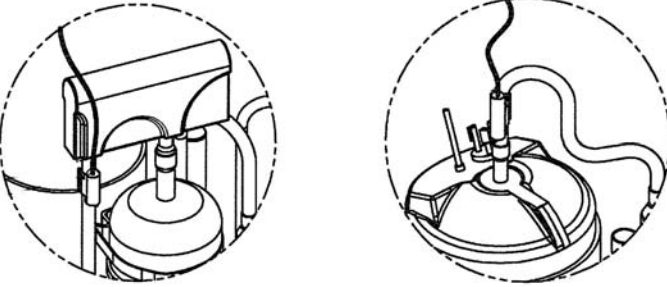
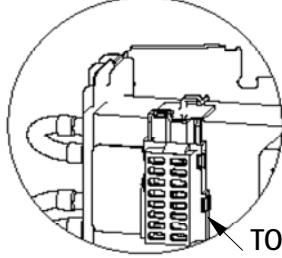
No.	Part name	Procedure	Remarks
⑪	TE sensor (outdoor heat exchanging temperature sensor) • Attachment Install the sensor onto the straight pipe part of the condenser output pipe.	 <p style="text-align: center;">Detail C for 10k Detail C for 13k</p>	 <p style="text-align: center;">Detail B Detail A Detail C</p>
⑫	TS sensor (Suction pipe temperature sensor) • Attachment Install the sensor onto the straight pipe part of the suction pipe. Be careful for the lead direction of the sensor.		 <p style="text-align: center;">Detail A TS sensor for 10k</p>
⑬	TD sensor (Discharge pipe temperature sensor) • Attachment With its leads pointed upward, install the sensor onto the vertical straight pipe part of the discharge pipe.		 <p style="text-align: center;">Detail B TD sensor for 10k</p>
⑭	TO sensor (Outside air temperature sensor) • Attachment Insert the outdoor air temperature sensor into the holder, and install the holder onto the heat exchanger.	 <p style="text-align: center;">Detail A Detail B TS sensor for 13k TD sensor for 13k</p>	 <p style="text-align: center;">Detail B TO sensor holder</p> <p style="text-align: center;">Arrow D TO sensor</p>
<p>CAUTION</p> <p>During the installation work (and on its completion), take care not to damage the coverings of the sensor leads on the edges of the metal plates or other parts. It is dangerous for these coverings to be damaged since damage may cause electric shocks and/or a fire.</p>			
<p>CAUTION</p> <p>After replacing the parts, check whether the positions where the sensors were installed are the proper positions as instructed. The product will not be controlled properly and trouble will result if the sensors have not been installed in their proper positions.</p>			

No.	Part name	Procedure	Remarks																												
⑮	<p>Replacement of temperature sensor for servicing only</p> <p>Common service parts of sensor TO, TS, TE, TD</p> <p>These are parts for servicing sensors. Please check that the accessories shown in the right table are packed.</p>	<ol style="list-style-type: none"> 1) Cut the sensor 100 mm longer than old one. 2) Cut the protective tube after pulling out it (200 mm). 3) Move the protective tube toward the thermal sensor side and tear the tip of lead wire in two then strip the covering part. 4) Pass the stripped part through the thermal constrictive tube. 5) Cut the old sensor 100 mm length on the connector side, and recycle that connector. 6) Tear the lead wire in two on the connector side and strip the covering part. 7) Twist the leads on the connector and sensor sides, and solder them. 8) Move the thermal constrictive tubes toward the soldered parts and heat them with the dryer and constricting them. 9) Wind the attached color tape round the both terminals of the protective tube when colored protective tube is used. 10) Fix the sensor again. 																													
		<p>NOTE</p> <ol style="list-style-type: none"> 1) Store the joint part of the sensor and the connector in the electric parts box. 2) Never joint them near the thermal sensor part. Otherwise it would cause insulation inferiority because of dew drops. 3) When replacing the sensor using the colored protective tube, wind the color tape matching the color of that tube. 																													
		<table border="1"> <thead> <tr> <th></th> <th>Parts name</th> <th>Q'ty</th> <th>Remarks</th> </tr> </thead> <tbody> <tr> <td>1</td> <td>Sensor</td> <td>1</td> <td>Length : 3m</td> </tr> <tr> <td>2</td> <td>Sensor Spring (A)</td> <td>1</td> <td>For spare</td> </tr> <tr> <td>3</td> <td>Sensor Spring (B)</td> <td>1</td> <td>For spare</td> </tr> <tr> <td>4</td> <td>Thermal constrictive tube</td> <td>3</td> <td>Including one spare</td> </tr> <tr> <td>5</td> <td>Color tape</td> <td>1</td> <td>9 colors</td> </tr> <tr> <td>6</td> <td>Terminal</td> <td>3</td> <td></td> </tr> </tbody> </table>		Parts name	Q'ty	Remarks	1	Sensor	1	Length : 3m	2	Sensor Spring (A)	1	For spare	3	Sensor Spring (B)	1	For spare	4	Thermal constrictive tube	3	Including one spare	5	Color tape	1	9 colors	6	Terminal	3		
	Parts name	Q'ty	Remarks																												
1	Sensor	1	Length : 3m																												
2	Sensor Spring (A)	1	For spare																												
3	Sensor Spring (B)	1	For spare																												
4	Thermal constrictive tube	3	Including one spare																												
5	Color tape	1	9 colors																												
6	Terminal	3																													

12-3. Outdoor Unit (RAS-18SAV-E)

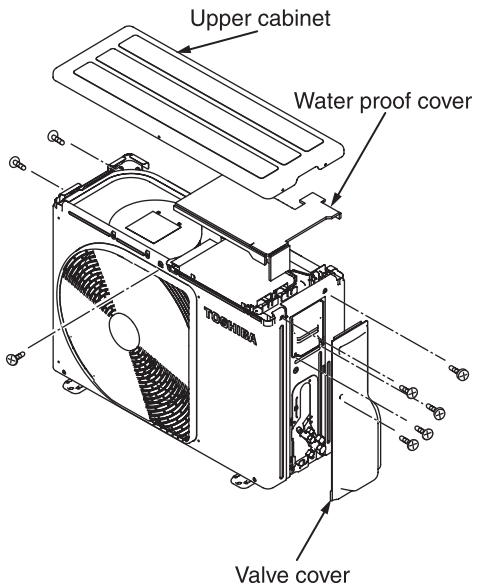
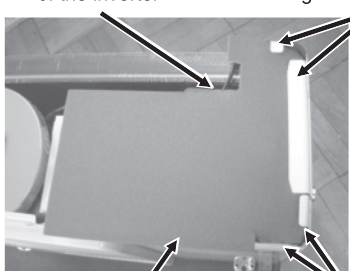
No.	Part name	Procedure	Remarks
①	Common procedure	<p>1. Detachment</p> <div style="border: 1px solid black; padding: 5px; margin: 10px 0;"> <p style="text-align: center;">NOTE</p> <p>Wear gloves for this job. Otherwise, you may injure your hands on the parts, etc.</p> </div> <ol style="list-style-type: none"> 1) Stop operation of the air conditioner, and turn off the main switch of the breaker for air conditioner. 2) Remove the valve cover. (ST1TØ4 × 8L 1 pc.) <ul style="list-style-type: none"> • After removing screw, remove the valve cover pulling it downward. 3) Remove wiring cover (ST1TØ4 × 8L 2 pcs.), and then remove connecting cable. 4) Remove the upper cabinet. (ST1TØ4 × 8L 5 pcs.) <ul style="list-style-type: none"> • After removing screws, remove the upper cabinet pulling it upward. <p>2. Attachment</p> <ol style="list-style-type: none"> 1) Attach the water-proof cover. <div style="border: 1px solid black; padding: 5px; margin: 10px 0;"> <p style="text-align: center;">NOTE</p> <p>The water-proof cover must be attached without fail in order to prevent rain water, etc. from entering inside the indoor unit.</p> </div> <ol style="list-style-type: none"> 2) Attach the upper cabinet. (ST1TØ4 × 8L 5 pcs.) 3) Perform cabling of connecting cable, and attach the wiring cover. <ul style="list-style-type: none"> • Place the wiring cover over the opening used to work on the connecting wires of the side cabinet, and secure it using the 2 fixing screws (ST1TØ4 × 8L 2 pcs.). At this point, the top cushion of the wiring cover must be on the inside of the opening. 4) Attach the valve cover. (ST1TØ4 × 8L 1 pc.) <ul style="list-style-type: none"> • Insert the upper part into the square hole of the side cabinet, set hook claws of the valve cover to square holes (at three positions) of the main unit, and attach it pushing upward. 	 <p style="text-align: center;">Insert the bent part into the rear panel of the inverter Bring into contact against these parts</p>  <p style="text-align: center;">Align the stitch line with the top edge of the front cabinet Bend downward, and align with the inside surface of the front cabinet</p> <div style="border: 1px solid black; padding: 5px; text-align: center; margin-top: 10px;"> <p>How to mount the water-proof cover</p> </div>

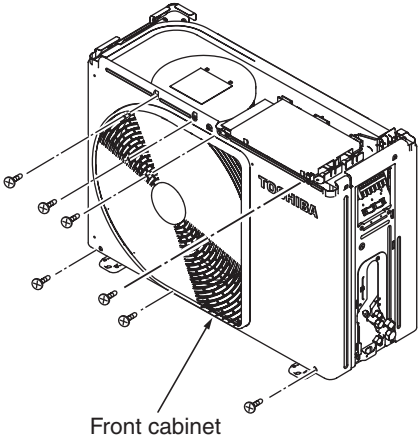
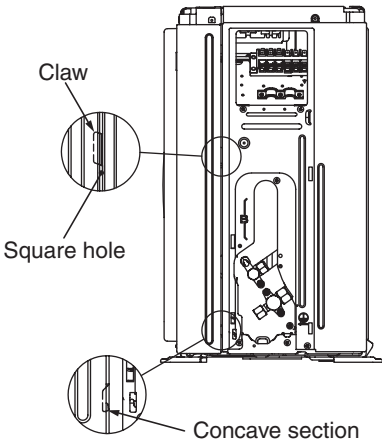
No.	Part name	Procedure	Remarks
②	Front cabinet	<p>1. Detachment</p> <ol style="list-style-type: none"> 1) Perform step 1 in ① . 2) Remove the fixing screws (ST1TØ4 × 8L 2 pcs.) used to secure the front cabinet and inverter cover, the screws (ST1TØ4 × 8L 3 pcs.) used to secure the front cabinet at the bottom, and the fixing screws (ST1TØ4 × 8L 2 pcs.) used to secure the motor base. <ul style="list-style-type: none"> • The front cabinet is fitted into the side cabinet (left) at the front left side so pull up the top of the front cabinet to remove it. <p>2. Attachment</p> <ol style="list-style-type: none"> 1) Insert the claw on the front left side into the side cabinet (left). 2) Hook the bottom part of the front right side onto the concave section of the bottom plate. Insert the claw of the side cabinet (right) into the square hole in the front cabinet. 3) Return the screws that were removed above to their original positions. 	 <p>Front cabinet</p>  <p>Claw</p> <p>Square hole</p> <p>Concave section</p>

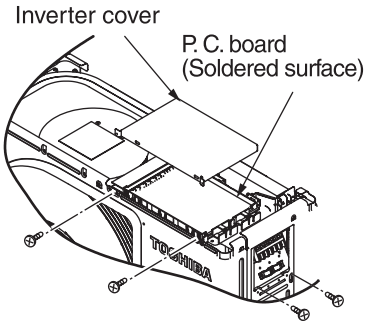
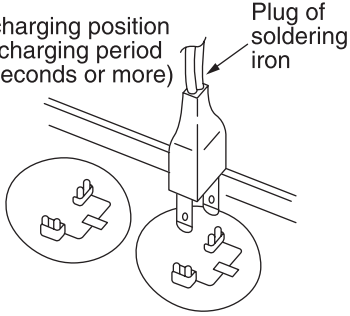
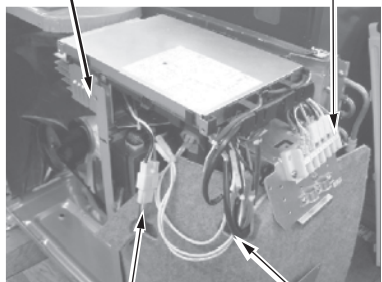
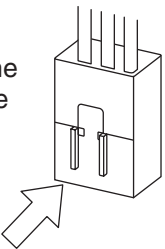
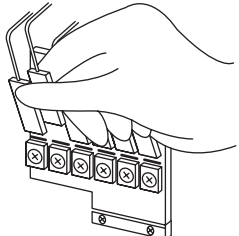
No.	Part name	Procedure	Remarks
③	Inverter assembly	<p>1) Perform work of item 1 in ① .</p> <p>2) Remove screw (ST1TØ4 × 8L 2 pcs.) of the upper part of the front cabinet.</p> <ul style="list-style-type: none"> • If removing the inverter cover in this condition, P.C. board can be checked. • If there is no space above the unit, perform work of 1 in ② . <div style="border: 1px solid black; padding: 5px; margin: 10px 0;"> <p>Be careful to check the inverter because high-voltage circuit is incorporated in it.</p> </div> <p>3) Perform discharging by connecting ⊕, ⊖ polarity by discharging resistance (approx. 100Ω40W) or plug of soldering iron to ⊕, ⊖ terminals of the C14 (printed “CAUTION HIGH VOLTAGE” is attached.) electrolytic capacitor (18SAV = 500μF, 22SAV: 760μF) on P.C. board.</p> <div style="border: 1px solid black; padding: 5px; margin: 10px 0;"> <p>Be careful to discharge the capacitor because the electrolytic capacitor cannot naturally discharge and voltage remains according to trouble type in some cases.</p> </div> <div style="text-align: center; margin: 10px 0;"> <p>NOTE</p> <p>This capacitor is one with mass capacity. Therefore, it is dangerous that a large spark generates if short-circuiting between ⊕, ⊖ polarity with screwdriver, etc. for discharging.</p> </div> <p>4) Remove screws (ST1TØ4 × 8L 2 pcs.) fixing the main body and the inverter box.</p> <p>5) Remove the front cabinet by performing step 1 in ②, and remove the fixing screws (ST1TØ4 × 8L) for securing the main body and inverter box.</p> <p>6) Remove various lead wires from the holder at upper part of the inverter box.</p> <p>7) Pull the inverter box upward.</p> <p>8) Disconnect connectors of various lead wires.</p> <div style="border: 1px solid black; padding: 5px; margin: 10px 0;"> <p>Requirement</p> <p>As each connector has a lock mechanism, avoid to remove the connector by holding the lead wire, but by holding the connector.</p> </div>	 <p>Inverter cover P.C. board (Soldered surface)</p>  <p>Discharging position (Discharging period 10 seconds or more) Plug of soldering iron</p> <p>A screw (STIT-4X8MSZN) Terminal block</p>  <p>Put the compressor leads through the hole Put each leads through the hole</p>  <p>The connector is one with lock, so remove it while pushing the part indicated by an arrow.</p>  <p>Be sure to remove the connector by holding the connector, not by pulling the lead wire.</p>

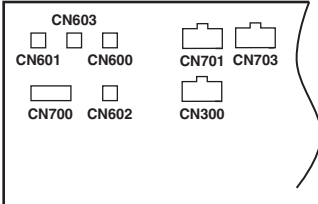
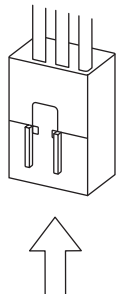
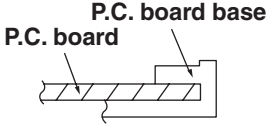
No.	Part name	Procedure	Remarks
④	Control board assembly	<p>1. Disconnect the leads and connectors connected to the other parts from the control board assembly.</p> <p>1) Leads</p> <ul style="list-style-type: none"> • 3 leads (black, white, orange) connected to terminal block. • Lead connected to compressor : Disconnect the connector (3P). • Lead connected to reactor : Disconnect the 2 connectors (2P). <p>2) Connectors (×7)</p> <p>CN300 : Outdoor fan motor (3P: white)* (See NOTE)</p> <p>CN701 : 4-way valve (2P: yellow)*</p> <p>CN600 : TE sensor (2P: white)*</p> <p>CN700 : PMV (6P: white)</p> <p>CN603 : TS sensor (3P: white)*</p> <p>CN601 :TD sensor (3P: white)*</p> <p>CN602 : TO sensor (2P: white)</p> <div style="border: 1px solid black; padding: 5px; margin: 10px 0; text-align: center;"> <p>NOTE</p> <p>These connectors have a disconnect prevention mechanism: as such, the lock on their housing must be released before they are disconnected.</p> </div> <p>2. Remove the control board assembly from the P.C. board base. (Remove the heat sink and control board assembly while keeping them screwed together.)</p> <div style="border: 1px solid black; padding: 5px; margin: 10px 0; text-align: center;"> <p>NOTE</p> <p>Disengage the 4 claws of the P.C. board base, hold the heat sink, and lift to remove it.</p> </div> <p>3. Remove the 2 fixing screws used to secure the heat sink and control board assembly.</p> <p>4. Mount the new control board assembly.</p> <div style="border: 1px solid black; padding: 5px; margin: 10px 0; text-align: center;"> <p>NOTE</p> <p>When mounting the new control board assembly, ensure that the P.C. board is inserted properly into the P.C. board support groove.</p> </div>	 <p>CN300, CN701, CN703, CN600 and CN603 are connectors with locking mechanisms: as such, to disconnect them, they must be pushed in the direction of the arrow while pulling them out.</p>  <p style="text-align: center;">↑</p>  <p style="text-align: center;">P.C. board base P.C. board</p>

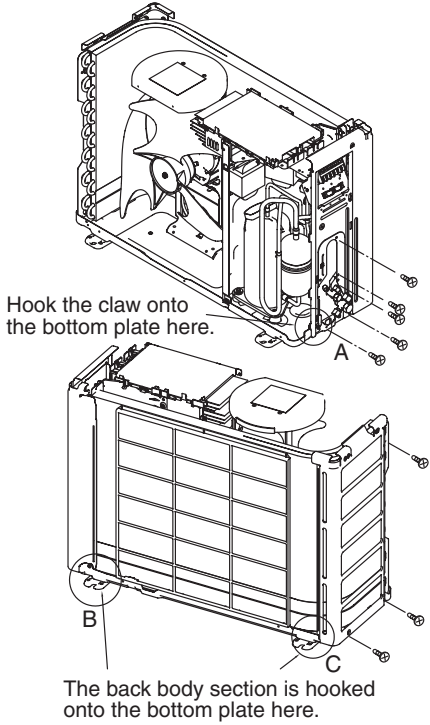
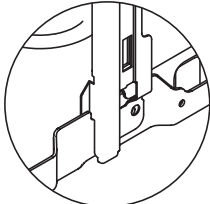
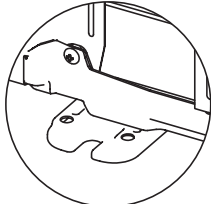
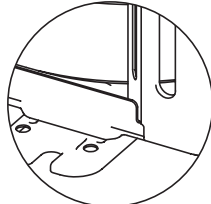
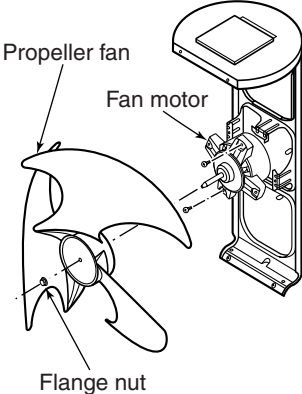
No.	Part name	Procedure	Remarks
⑤	Side cabinet	<p>1. Side cabinet (right)</p> <ol style="list-style-type: none"> 1) Perform step 1 in ② and all the steps in ③ . 2) Remove the fixing screw (ST1TØ4 × 8L 5 pcs.) used for securing the side cabinet to the bottom plate and valve fixing panel. <p>2. Side cabinet (left)</p> <ol style="list-style-type: none"> 1) Perform step 1 in ② . 2) Remove the fixing screw (ST1TØ4 × 8L 1 pcs.) used to secure the side cabinet (left) onto the heat exchanger. 3) Remove the fixing screw (ST1TØ4 × 8L 2 pc.) used for securing the side cabinet to the bottom plate and heat exchanger. 	 <p>Hook the claw onto the bottom plate here.</p> <p>The back body section is hooked onto the bottom plate here.</p> <div style="display: flex; justify-content: space-around; margin-top: 20px;"> <div style="text-align: center;">  <p>Detail A</p> </div> <div style="text-align: center;">  <p>Detail B</p> </div> <div style="text-align: center;">  <p>Detail C</p> </div> </div>
⑥	Fan motor	<ol style="list-style-type: none"> 1) Perform work of item 1 of ① and ② . 2) Remove the flange nut fixing the fan motor and the propeller. <ul style="list-style-type: none"> • Flange nut is loosened by turning clockwise. (To tighten the flange nut, turn counterclockwise.) 3) Remove the propeller fan. 4) Disconnect the connector for fan motor from the inverter. 5) Remove the fixing screws (2 pc.) holding by hands so that the fan motor does not fall. <p>* Precautions when assembling the fan motor.</p> <p>Tighten the flange nut using a tightening torque of 4.9 N•m.</p>	 <p>Propeller fan</p> <p>Fan motor</p> <p>Flange nut</p>

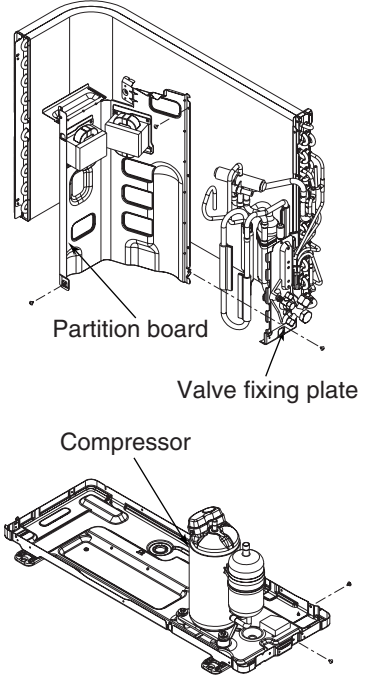
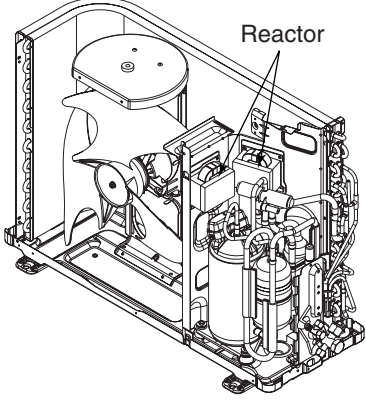
No.	Part name	Procedure	Remarks
⑦	Compressor	<ol style="list-style-type: none"> 1) Perform work of item 1 of ① and ②, ③, ④, ⑤. 2) Extract refrigerant gas. 3) Remove the partition board. (ST1T04 × 8L 3 pcs.) 4) Remove the sound-insulation material. 5) Remove terminal cover of the compressor, and disconnect lead wire of the compressor from the terminal. 6) Remove pipe connected to the compressor with a burner. <ul style="list-style-type: none"> • Take care to keep the 4-way valve away from naked flames. (Otherwise, it may malfunction.) 7) Remove the fixing screw of the bottom plate and heat exchanger. (ST1T04 × 8L 1 pc.) 8) Remove the fixing screw of the bottom plate and valve fixing plate. (ST1T04 × 8L 1 pc.) 9) Pull upward the refrigeration cycle. 10) Remove bolt (3 pcs.) fixing the compressor to the bottom plate. <ul style="list-style-type: none"> * <u>Precautions when assembling the compressor.</u> Tighten the compressor bolts using a tightening torque of 4.9 N•m. 	 <p>Partition board</p> <p>Valve fixing plate</p> <p>Compressor</p>
⑧	Reactor	<ol style="list-style-type: none"> 1) Perform work of item 1 of ②, and ③. 2) Remove screws fixing the reactor. (ST1T04 × 8L 4 pcs.) 	 <p>Reactor</p>

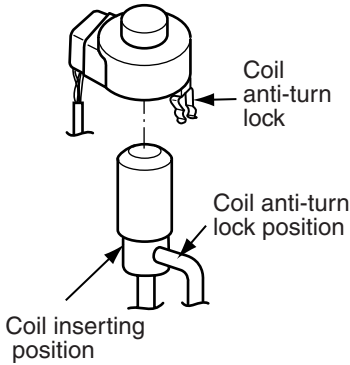
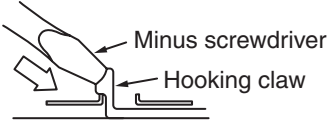
No.	Part name	Procedure	Remarks
⑨	Electronic expansion valve coil	<p>1. Detachment</p> <ol style="list-style-type: none"> 1) Perform step 1 in ②, all the steps in ③ and 1 in ⑤. 2) Remove the coil by pulling it up from the electronic control valve body. <p>2. Attachment</p> <ol style="list-style-type: none"> 1) When assembling the coil into the valve body, ensure that the coil anti-turn lock is installed properly in the pipe. <p><Handling precaution> When handling the parts, do not pull the leads. When removing the coil from the valve body, use your hand to secure the body in order to prevent the pipe from being bent out of shape.</p>	
⑩	Fan guard	<p>1. Detachment</p> <ol style="list-style-type: none"> 1) Perform work of item 1 of ②. 2) Remove the front cabinet, and put it down so that fan guard side directs downward. <div style="border: 1px solid black; padding: 5px; margin: 10px 0;"> <p>Perform work on a corrugated cardboard, cloth, etc. to prevent flaw to the product.</p> </div> <ol style="list-style-type: none"> 3) Remove the hooking claws by pushing minus screwdriver according to the arrow mark in the right figure, and remove the fan guard. <p>2. Attachment</p> <ol style="list-style-type: none"> 1) Insert claws of the fan guard in the holes of the front cabinet. Push the hooking claws (9 positions) by hands and fix the claws. <div style="border: 1px solid black; padding: 5px; margin: 10px 0;"> <p>All the attaching works have completed. Check that all the hooking claws are fixed to the specified positions.</p> </div>	

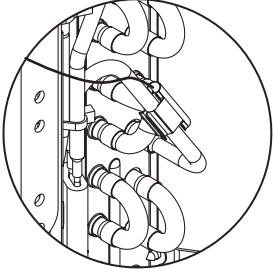
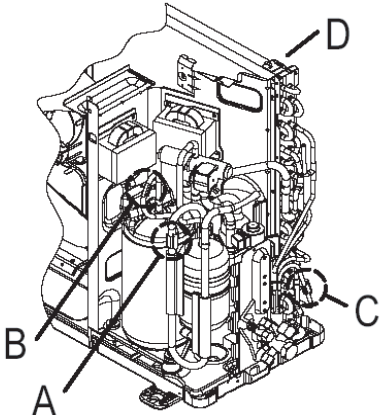
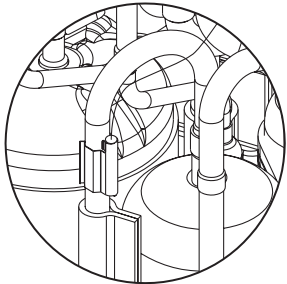
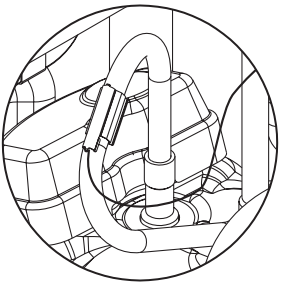
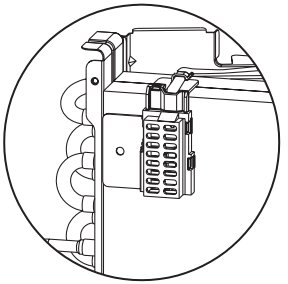
No.	Part name	Procedure	Remarks
⑪	TE sensor (Outdoor heat exchanging temperature sensor) • Attachment With the leads pointing downward and the sensor leads pointing in the direction shown in the figure, install the sensor onto the straight pipe part of the condenser output pipe.	 <p style="text-align: center;">Detail C for RAS-18SAV-E</p>	
⑫	TS sensor (Suction pipe temperature sensor) • Attachment With its leads pointing downward, point the sensor in the direction of the packed valve, and install it onto the straight pipe part of the suction pipe.		
⑬	TD sensor (Discharge pipe temperature sensor) • Attachment With its leads pointed downward, install the sensor onto the vertical straight pipe part of the discharge pipe.		
⑭	TO sensor (Outside air temperature sensor) • Attachment Insert the outdoor air temperature sensor into the holder, and install the holder onto the heat exchanger.	 <p style="text-align: center;">Detail A TS sensor</p>  <p style="text-align: center;">Detail B TD sensor</p>  <p style="text-align: center;">Arrow D TO sensor</p>	
<p>CAUTION</p> <p>During the installation work (and on its completion), take care not to damage the coverings of the sensor leads on the edges of the metal plates or other parts. It is dangerous for these coverings to be damaged since damage may cause electric shocks and/or a fire.</p>			
<p>CAUTION</p> <p>After replacing the parts, check whether the positions where the sensors were installed are the proper positions as instructed. The product will not be controlled properly and trouble will result if the sensors have not been installed in their proper positions.</p>			

13. EXPLODED VIEWS AND PARTS LIST

13-1. Indoor Unit (1)

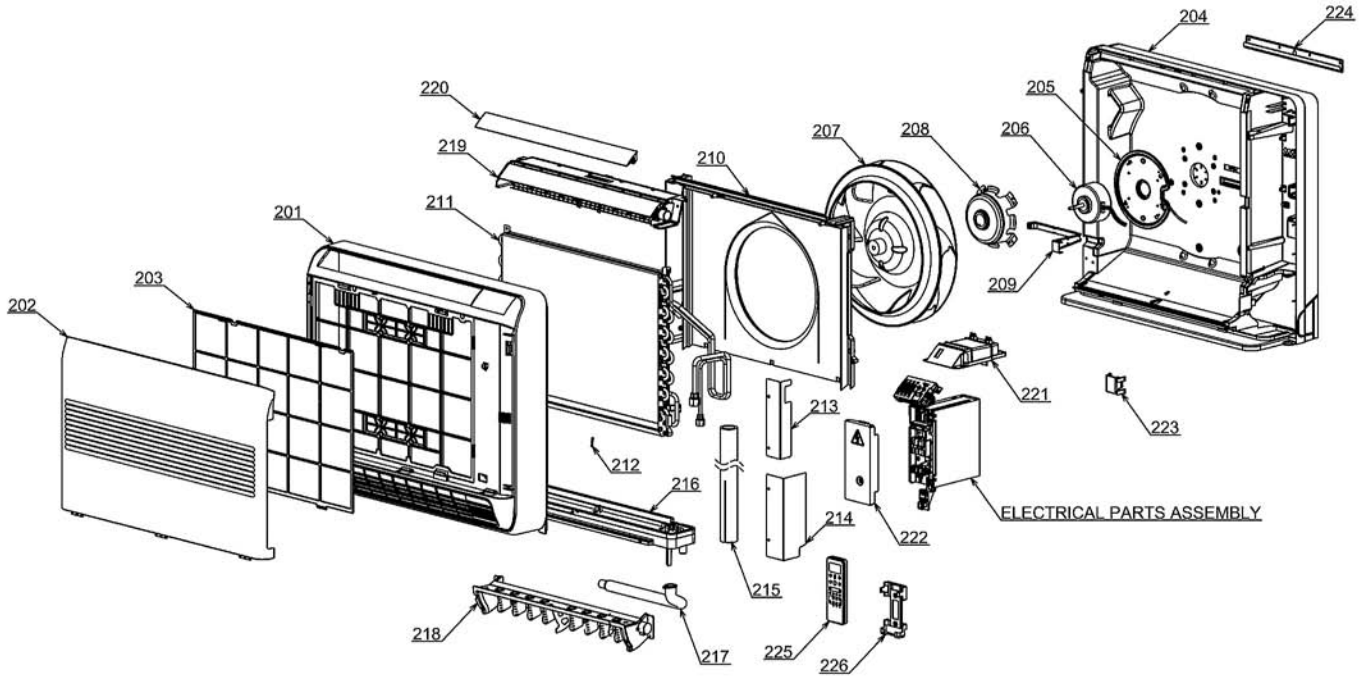

Location No.	Part No.	Description	Location No.	Part No.	Description
201	43T00553	FRONT PANEL ASSY	212	43T19333	HOLDER, SENSOR (Made in Japan)
202	43T09460	INLET GRILLE ASSY	213	43T79314	DRAIN GUIDE (UP)
203	43T80325	AIR FILTER	214	43T79315	DRAIN GUIDE (DOWN)
204	43T03379	BACK BODY ASSY	215	43T49341	SHIELD PIPE
205	43T39340	MOTOR BASE ASSY	216	43T72310	DRAIN PAN ASSY
206	43T21424	FAN MOTOR ASSY	217	43T70313	HOSE, DRAIN (Made in Thailand)
207	43T20330	TURBO FAN ASSY	218	43T22317	DAMPER ASSY
208	43T60408	MOTOR HOLDER	219	43T22316	UPPER LOUVER ASSY
209	43T63331	LEAD COVER	220	43T22315	HORIZONTAL LOUVER
210	43T22314	BELL MOUTH ASSY	221	43T63333	DISPLAY BASE
211	43T44455	REFRIGERANT CYCLE ASSY (FOR RAS-B10UFV-E)	222	43T62339	TERMINAL COVER ASSY
211	43T44456	REFRIGERANT CYCLE ASSY (FOR RAS-B13UFV-E)	223	43T49340	PIPE HOLDER
211	43T44457	REFRIGERANT CYCLE ASSY (FOR RAS-B18UFV-E)	224	43T82316	PLATE MOUNTING
			225	43T66309	WIRELESS REMOTE CONTROLLER
			226	43T83003	HOLDER, REMOTE CONTROL (Made in Thailand)

13-2. Indoor Unit (E-Part)

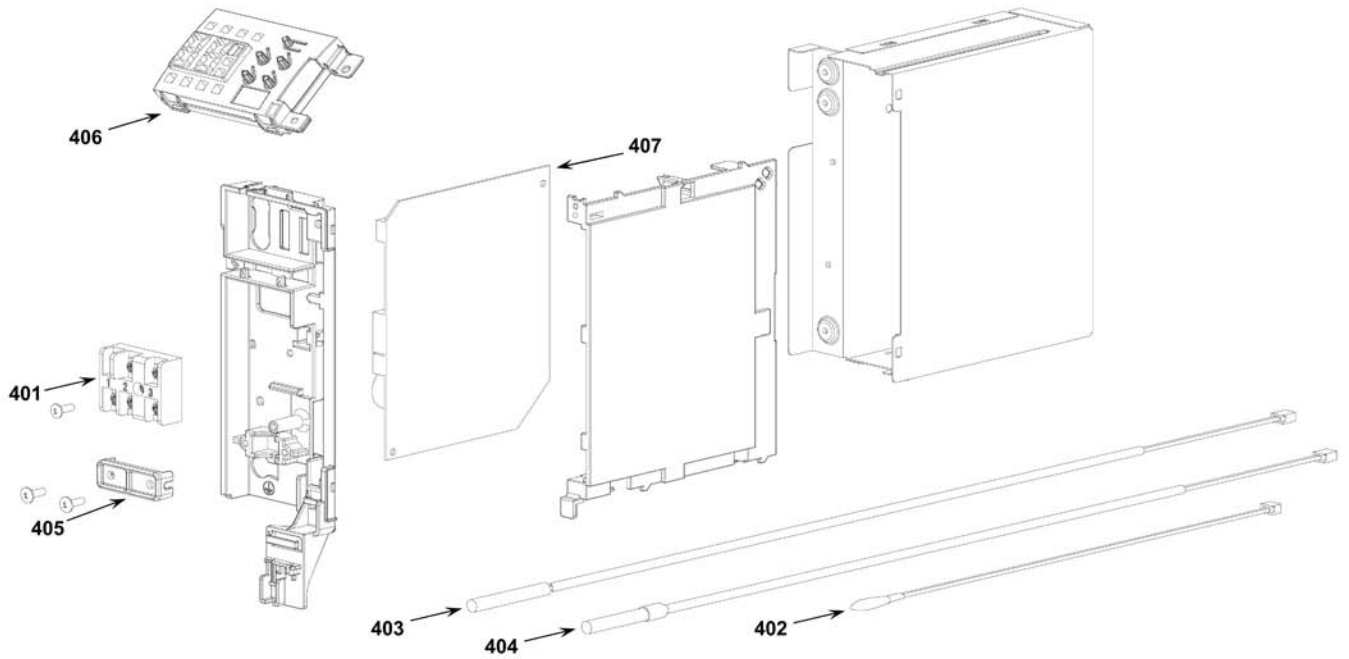

Location No.	Part No.	Description	Location No.	Part No.	Description
401	43T60406	TERMINAL 3P	406	43T69865	PC BOARD ASSY,WRS-LED
402	43T50321	SENSOR;THERMOSTAT	407	43T69866	PC BOARD (FOR RAS-B10UFV-E)
403	43T50332	SENSOR:HEAT EXCHANGER	407	43T69867	PC BOARD (FOR RAS-B13UFV-E)
404	43T50333	SENSOR:HEAT EXCHANGER	407	43T69868	PC BOARD (FOR RAS-B18UFV-E)
405	43T62003	CORD CLAMP (Made in Thailand)			

13-3. Outdoor Unit (RAS-10,13SAV2-E)

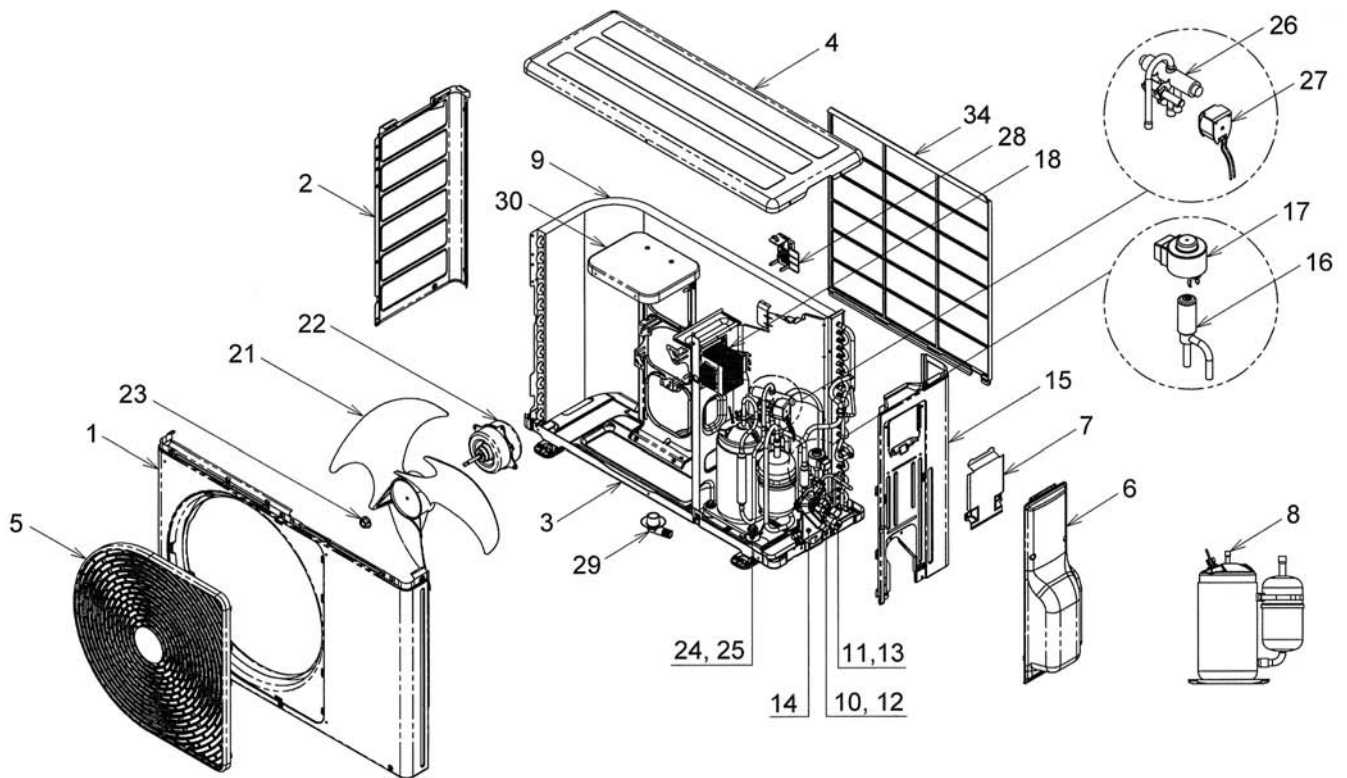

31 HOLDER SENSOR (TE) ; For PIPE OD 6.35 mm.
 32 HOLDER SENSOR (TD) ; For PIPE OD 8.00 mm.
 33 HOLDER SENSOR (TS) ; For PIPE OD 9.52 mm.

Location No.	Part No.	Description	Location No.	Part No.	Description
1	43T00468	FRONT CABINET	14	43T00448	FIXING PLATE VALVE
2	43T00459	LEFT CABINET (Made in Thailand)	15	43T00451	RIGHT CABINET ASSEMBLY
3	43T42327	BASE PLATE ASSEMBLY (Made in Thailand)	16	43T46347	BODY-PMV
4	43T00452	UPPER CABINET (Made in Thailand)	17	43T63332	COIL-PMV
5	43T19329	FAN GUARD	18	43T46351	REACTOR (Made in Thailand)
6	43T19330	PACKED VALVE COVER	21	43T20319	PROPELLER FAN (Made in Thailand)
7	43T62325	ELECTRIC PART COVER	22	43T21375	FAN-MOTOR
8	43T41420	COMPRESSOR (Made in China)	23	43T47001	NUT FLANGE (Made in Japan)
9	43T43410	CONDENSER ASSEMBLY (FOR RAS-10SAV2-E)	24	43T97001	NUT
9	43T43434	CONDENSER ASSEMBLY (FOR RAS-13SAV2-E)	25	43T49335	RUBBER CUSHION (Made in Malaysia)
10	43T46332	VALVE;PACKED 6.35 DIA (Made in Thailand)	26	43T46343	4 WAY VALVE
11	43T46331	VALVE;PACKED 9.52 DIA (Made in Thailand)	27	43T63320	4 WAY VALVE COIL ASSEMBLY
12	43T47331	BONNET, 6.35 DIA (Made in Thailand)	28	43T63319	HOLDER,SENSOR (Made in Thailand)
13	43T47332	BONNET, 9.52 DIA (Made in Thailand)	29	43T79305	DRAIN NIPPLE
			30	43T39333	MOTOR BASE CONNECTION PLATE
			31	43T63318	HOLDER,SENSOR (Made in Japan)
			32	43T63317	HOLDER,SENSOR (Made in Japan)
			33	43T63316	HOLDER,SENSOR (Made in Japan)
			34	43T19331	FIN GUARD (Made in Thailand)

13-4. Outdoor Unit (RAS-18SAV2-E)

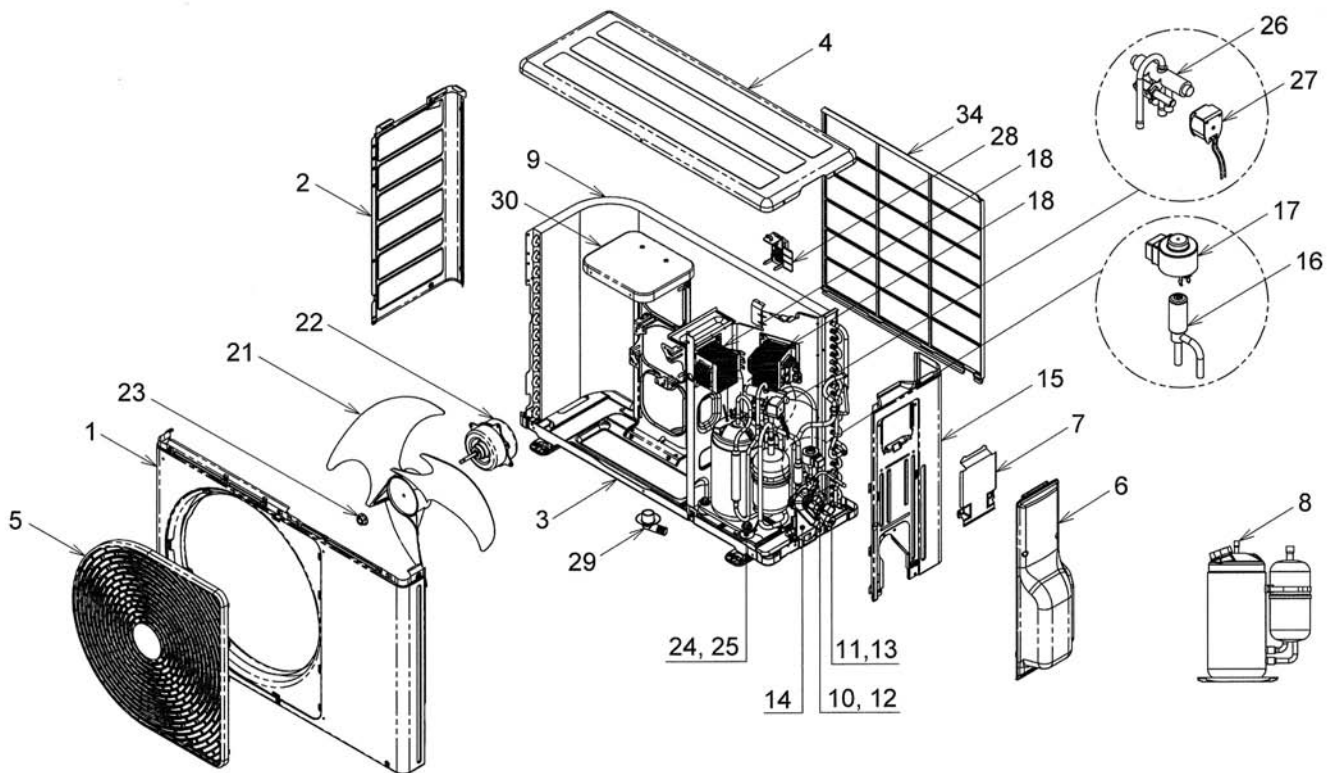

31 HOLDER SENSOR (TE) ; For PIPE OD 6.35 mm.
 32 HOLDER SENSOR (TD) ; For PIPE OD 8.00 mm.
 33 HOLDER SENSOR (TS) ; For PIPE OD 12.7 mm.

Location No.	Part No.	Description	Location No.	Part No.	Description
1	43T00468	FRONT CABINET	17	43T63332	COIL-PMV
2	43T00459	LEFT CABINET (Made in Thailand)	18	43T58306	REACTOR (Made in Thailand)
3	43T42327	BASE PLATE ASSEMBLY (Made in Thailand)	21	43T20319	PROPELLER FAN (Made in Thailand)
4	43T00452	UPPER CABINET (Made in Thailand)	22	43T21375	FAN-MOTOR
5	43T19329	FAN GUARD	23	43T47001	NUT FLANGE (Made in Japan)
6	43T19330	PACKED VALVE COVER	24	43T97001	NUT
7	43T62325	ELECTRIC PART COVER	25	43T49335	RUBBER CUSHION (Made in Malaysia)
8	43T41430	COMPRESSOR	26	43T46343	4 WAY VALVE
9	43T43451	CONDENSER ASSEMBLY	27	43T63320	4 WAY VALVE COIL ASSEMBLY
10	43T46358	VALVE;PACKED 6.35 DIA	28	43T63319	HOLDER,SENSOR (Made in Thailand)
11	43T46355	VALVE;PACKED 12.7 DIA (H4)	29	43T79305	DRAIN NIPPLE
12	43T47331	BONNET, 6.35 DIA (Made in Thailand)	30	43T39333	MOTOR BASE CONNECTION PLATE
13	43T47333	BONNET, 12.70 DIA (Made in Thailand)	31	43T63318	HOLDER,SENSOR (Made in Japan)
14	43T00448	FIXING PLATE VALVE	32	43T63317	HOLDER,SENSOR (Made in Japan)
15	43T00451	RIGHT CABINET ASSEMBLY	33	43T63323	HOLDER,SENSOR (Made in Japan)
16	43T46347	BODY-PMV	34	43T19331	FIN GUARD (Made in Thailand)

13-5. P.C. Board Layout (RAS-10, 13SAV2-E)

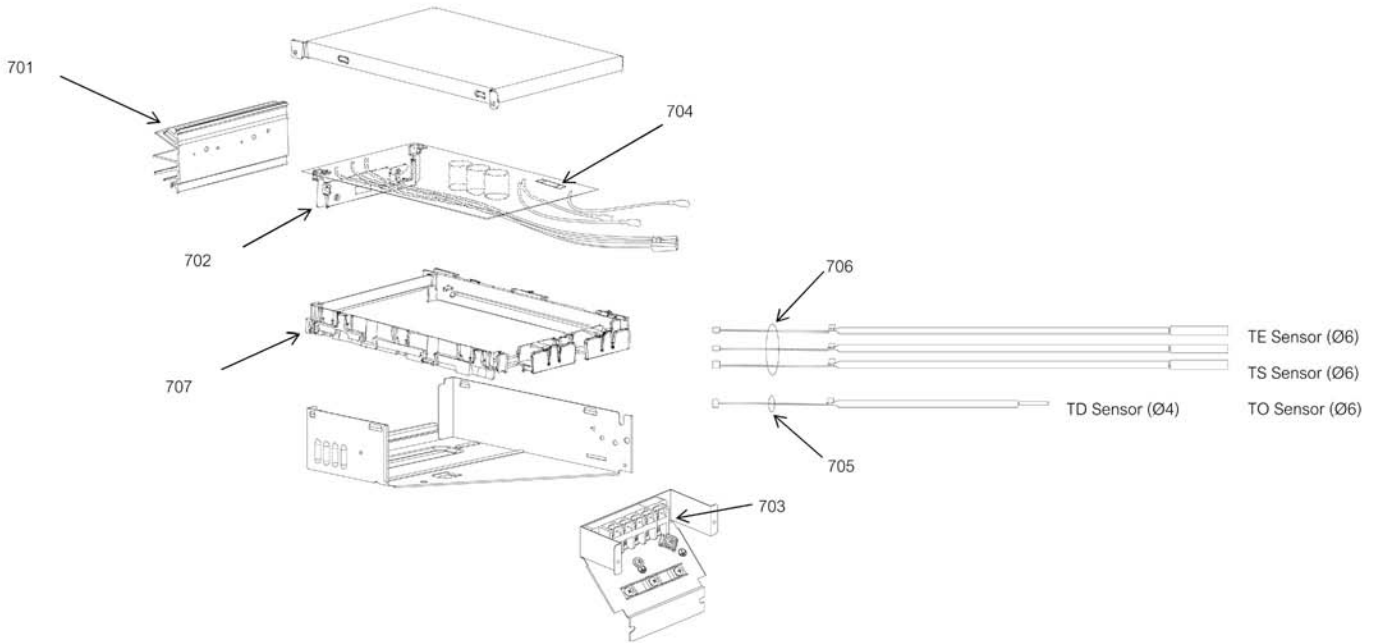

Location No.	Part No.	Description	Location No.	Part No.	Description
701	43T62320	HEATSINK (Made in Thailand)	705	43T60377	TEMPERATURE SENSOR
702	43T69780	PC BOARD (FOR RAS-10SAV2-E)	706	43T50304	SENSOR;HEAT EXCHANGER
702	43T69815	PC BOARD (FOR RAS-13SAV2-E)			(Made in Thailand)
703	43T60392	TERMINAL-5P	707	43T62313	BASE-PLATE-PC
704	43T60326	FUSE			(Made in Thailand)

13-6. P.C. Board Layout (RAS-18SAV2-E)

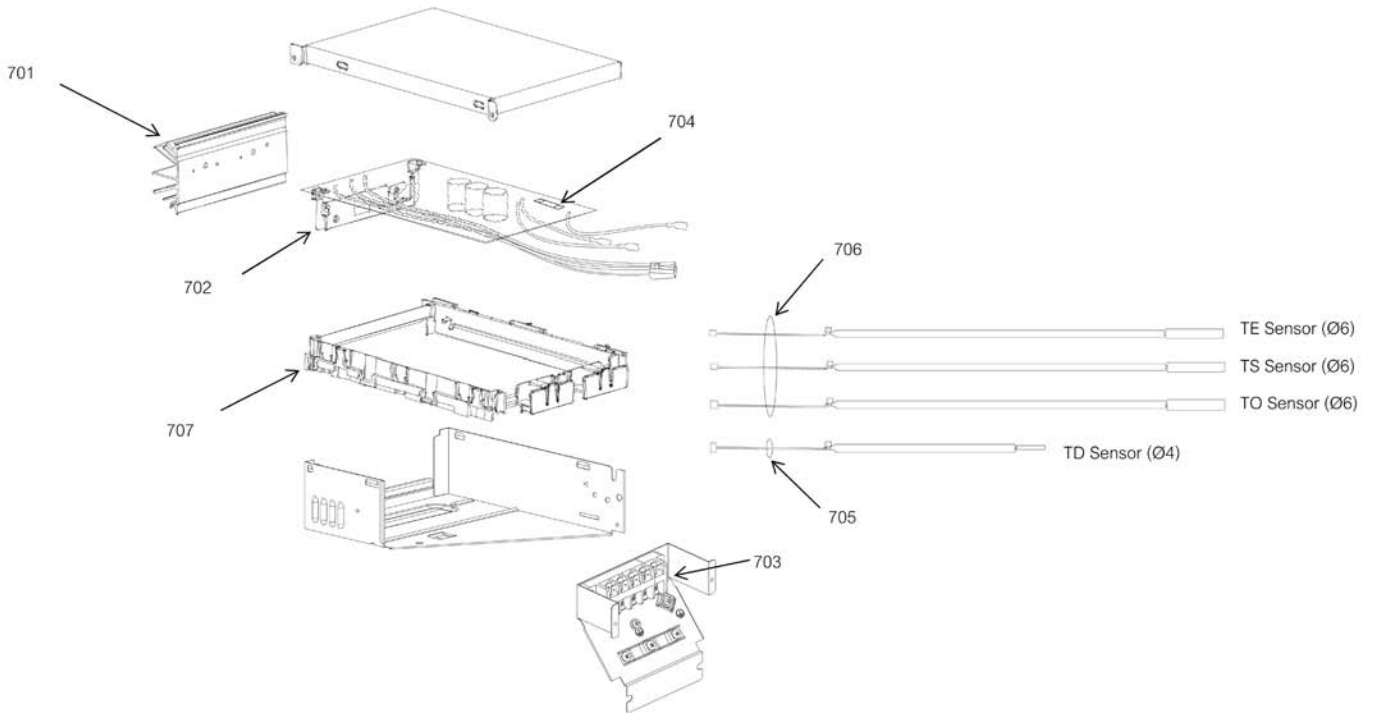

Location No.	Part No.	Description	Location No.	Part No.	Description
701	43T62320	HEATSINK (Made in Thailand)	705	43T60377	TEMPERATURE SENSOR
702	43T69880	PC BOARD (Made in Thailand)	706	43T50304	SENSOR;HEAT EXCHANGER (Made in Thailand)
703	43T60392	TERMINAL-5P	707	43T62313	BASE-PLATE-PC (Made in Thailand)
704	43T60326	FUSE			

13-7. P.C. Board Layout (RAS-18SAV-E)

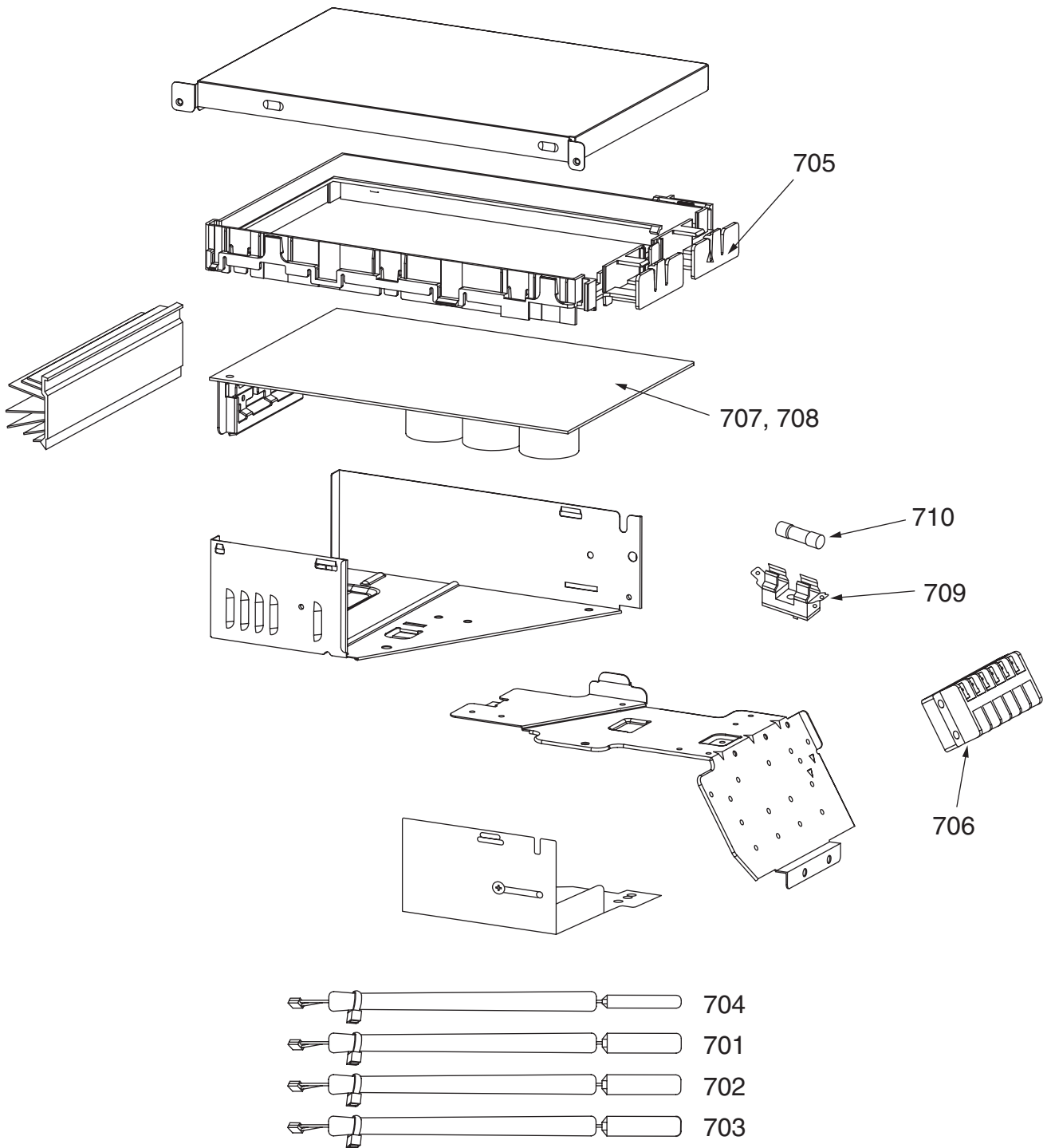

Location No.	Part No.	Description
701	43050422	Sensor, TE
702	43050423	Sensor, TS
703	43050427	Sensor, TO
704	43050430	Sensor, TD
705	43062228	Base, P.C. board
706	43160566	Terminal block, 6P, 20A

Location No.	Part No.	Description
707	4306V029	P.C. board Ass'y, MCC5009
709	43160571	Fuse, Holder, 15A, 250V
710	43160590	Fuse

TOSHIBA CARRIER (THAILAND) CO., LTD.

144/9 MOO 5, BANGKADI INDUSTRIAL PARK, TIVANON ROAD, TAMBOL BANGKADI,
AMPHUR MUANG, PATHUMTHANI 12000, THAILAND.