



CIAT - MAMBO Console air conditioner

MAMBO Console 12HV Console air conditioner

Features

- Infra-red controller as standard (wired available).
- Full Wi-Fi compatibility.
- Optional 'follow me' function.
- Compact design.
- Optimised air distribution.
- Stylish and lightweight.



Technical Data

Model reference			MAMBO - Console 12HV
Indoor unit			42HC12VSC
Outdoor unit			38HU12VSC
Cooling capacity	Min./nom./max.	kW	1.00/3.52/3.50
Heating capacity*	Min./nom./max.	kW	1.00/3.70/4.00
	@ -7 °C	kW	2.80
	@ -10 °C	kW	2.60
	@ -15 °C	kW	2.40
SEER		W/W	5.9
SCOP	Warmer/average	W/W	4.0/4.9
Energy label	SEER		A+
	SCOP warmer/average		A+/A++
Rated current		A	10
Rated input		kW	2.30
Power supply		V/ph/Hz	220-240/1/50
Power to			Outdoor
Interconnecting			5
Refrigerant amount	R410A	kg	1.05
Liquid side - gas side		inch	1/4 - 3/8
Standard piping length	Min./max. piping length	m	3/25
	Max. height difference	m	10
	Additional charge	g/m	15
Indoor unit			42HC12VSC
Sound power level**		dB(A)	60
Sound pressure level**	High/med./low	dB(A)	45/43/38
Air flow	High/med./low	m ³ /h	530/480/360
Weight		kg	15.0/19.5
Dimension	W x D x H	mm	700 x 600 x 210

* -7 °C/-10 °C/-15 °C heating at free frequency

** Sound data in cooling mode

Dimensional Drawings

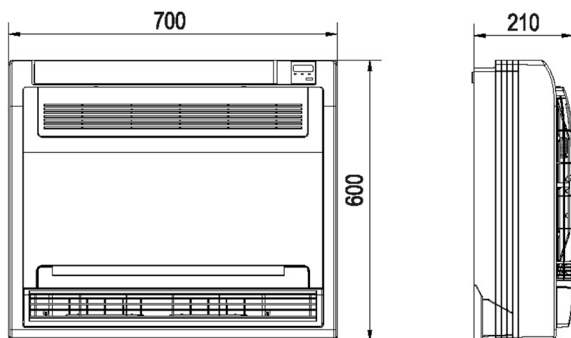

Cool Designs Ltd

Raising the Standards in Air Conditioning Distribution

www.cdlweb.info





CIAT - MAMBO Console air conditioner

MAMBO Console 12HV
Console air conditioner



Outdoor unit			38HU12VSC
Sound power level**		dB(A)	65
Sound pressure level**		dB(A)	56
Air flow		m ³ /h	2100
Weight		kg	28.5/31.5
Dimension	W x D x H	mm	800 x 333 x 554

** Sound data in cooling mode

Dimensional Drawings

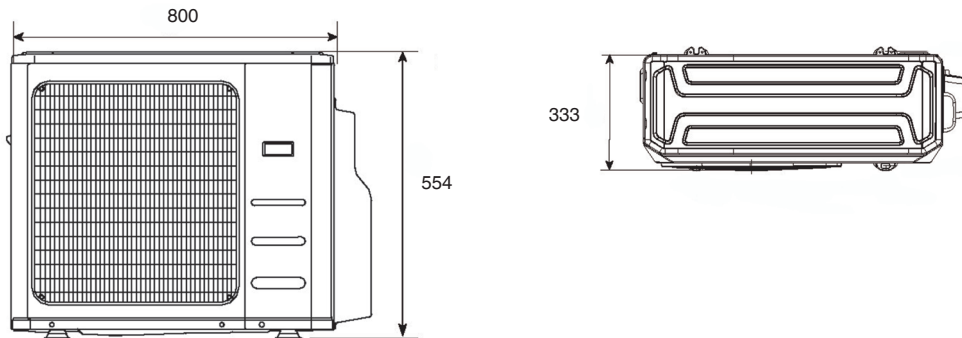

Accessories

Description	Part Number
Wired remote control for LC range - KJR-12- G2	7511630
Centralised wired remote control for LC range connectable up to 64 units - CCM-30	7511631

Split-system unit ratings are based on the following conditions:

Cooling capacities: Indoor air temperature 27°C (DB)/19°C (WB) - Outdoor air temperature 35°C (DB)/24°C (WB)

Heating capacities: Indoor air temperature 20°C (DB)/15°C (WB) - Outdoor air temperature 7°C (DB)/6°C (WB)

Cool Designs Ltd

Raising the Standards in Air Conditioning Distribution

www.cdlweb.info

