



CIAT - MAMBO Universal air conditioner

MAMBO Ceiling 36HV Universal air conditioner

Features

- Infra-red controller as standard (wired available).
- Full Wi-Fi compatibility.
- Can be installed vertically or horizontally.
- Fresh air connection.
- Easy access from inside the grille.
- 3D air flow meaning air intake from bottom or rear.



Technical Data

Model reference		MAMBO - Ceiling 36HV	
Indoor unit		42HU36VSC	
Outdoor unit		38HU36VSC	
Cooling capacity	Min./nom./max.	kW	4.40/10.40/11.00
Heating capacity*	Min./nom./max.	kW	3.70/11.90/13.80
	@ -7 °C	kW	9.80
	@ -10 °C	kW	8.40
	@ -15 °C	kW	8.20
SEER		W/W	6.3
SCOP	Warmer/average	W/W	4.0/5.1
Energy label	SEER		A++
	SCOP warmer/average		A+/A+++
Rated current		A	23
Rated input		kW	4.80
Power supply		V/ph/Hz	220-240/1/50
Power to			Both
Interconnecting			2
Refrigerant amount	R410A	kg	3.65
Liquid side - gas side		inch	3/8 - 5/8
Standard piping length	Min./max. piping length	m	3/50
	Max. height difference	m	25
	Additional charge	g/m	30
Indoor unit			42HU36VSC
Sound power level**		dB(A)	65
Sound pressure level**	High/med./low	dB(A)	55/51/46
Air flow	High/med./low	m ³ /h	2000/1700/1350
Weight		kg	38.0/44.0
Dimension	W x D x H	mm	1650 x 675 x 235

* -7 °C/-10 °C/-15 °C heating at free frequency

** Sound data in cooling mode

Dimensional Drawings

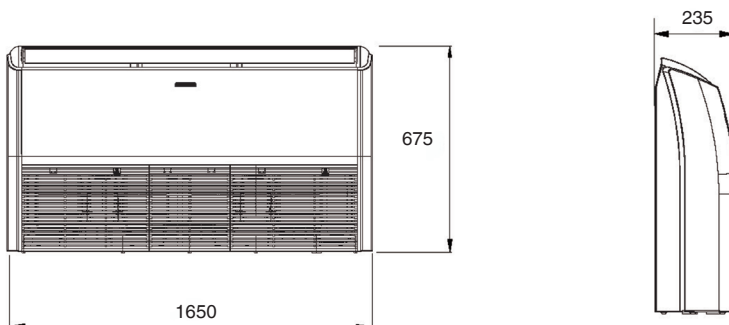

Cool Designs Ltd

Raising the Standards in Air Conditioning Distribution

www.cdlweb.info





CIAT - MAMBO Universal air conditioner

**MAMBO Ceiling 36HV
Universal air conditioner**



Outdoor unit			38HU36VSC
Sound power level**		dB(A)	70
Sound pressure level**		dB(A)	64
Air flow		m ³ /h	4150
Weight		kg	70.5/76.1
Dimension	W x D x H	mm	946 x 410 x 810

** Sound data in cooling mode

Dimensional Drawings

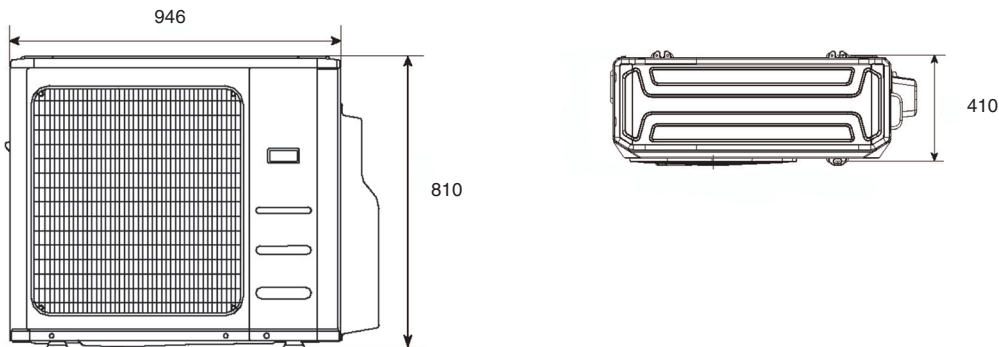

Accessories

Description	Part Number
Wired remote control for LC range - KJR-12- G2	7511630
Centralised wired remote control for LC range connectable up to 64 units - CCM-30	7511631

Split-system unit ratings are based on the following conditions:

Cooling capacities: Indoor air temperature 27°C (DB)/19°C (WB) - Outdoor air temperature 35°C (DB)/24°C (WB)

Heating capacities: Indoor air temperature 20°C (DB)/15°C (WB) - Outdoor air temperature 7°C (DB)/6°C (WB)

Cool Designs Ltd

Raising the Standards in Air Conditioning Distribution

www.cdlweb.info

