

TOSHIBA

INSTALLATION MANUAL

AIR CONDITIONER (SPLIT TYPE)

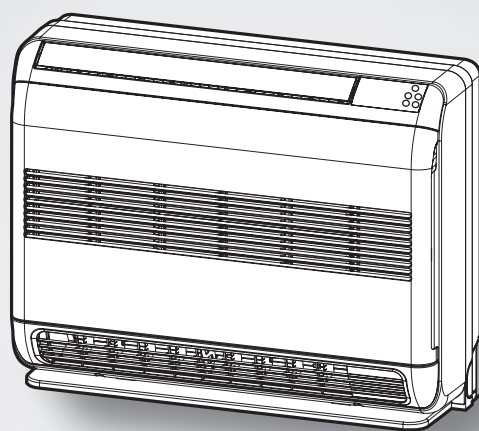

Indoor unit
RAS-(B) 10, 13, 18UFV Series

Outdoor unit
RAS-10, 13, 18SAV Series
RAS-M14GAV-E
RAS-M18GAV-E
RAS-3M18SAV-E
RAS-3M26GAV-E1
RAS-4M23SAV-E
RAS-4M27GAV-E1
RAS-5M34UAV-E

ENGLISH

ESPAÑOL

FRANÇAIS

ITALIANO

DEUTSCH

PORTUGUÊS

POLSKI

ČESKY

РУССКИЙ

HRVATSKI

MAGYAR

TÜRKÇE

NEDERLANDS

ΕΛΛΗΝΙΚΑ

SVENSKA

SUOMI

NORSK

DANSK

ROMÂNĂ

БЪЛГАРСКИ

EESTI

LATVISKI

SLOVENČINA

SLOVENŠČINA

EN CONTENTS

PRECAUTIONS FOR SAFETY 1
INSTALLATION DIAGRAM OF INDOOR AND OUTDOOR UNITS 3
INDOOR UNIT 4
OUTDOOR UNIT 7
OTHERS 9

IT INDICE

PRECAUZIONI PER LA SICUREZZA 1
SCHEMA DI INSTALLAZIONE DELL' UNITA' INTERNA E DELL' UNITA' ESTERNA 3
UNITA' INTERNA 4
UNITA' ESTERNA 7
ALTRI 9

PL SPIS TREŚCI

ZASADY BEZPIECZEŃSTWA 1
SCHEMAT INSTALACYJNY URZĄDZENIA WEWNĘTRZNEGO I ZEWNĘTRZNEGO 3
URZĄDZENIE WEWNĘTRZNE 4
URZĄDZENIE ZEWNĘTRZNE 7
INNE 9

CR SADRŽAJ

MJERE SIGURNOSTI 1
SHEMA UGRADNJE UNUTARNJIH I VANJSKIH JEDINICA 3
UNUTARNJA JEDINICA 4
VANJSKA JEDINICA 7
OSTALO 9

ES CONTENIDOS

PRECAUCIONES SOBRE SEGURIDAD 1
DIAGRAMA DE INSTALACIÓN DE LA UNIDAD INTERIOR Y EXTERIOR 3
UNIDAD INTERIOR 4
UNIDAD EXTERIOR 7
OTROS 9

DE INHALT

SICHERHEITSVORKEHRUNGEN 1
EINBAUZEICHNUNGEN FÜR INNEN- UND AUSSEGERÄT 3
INNEGERÄT 4
AUSSEGERÄT 7
SONSTIGES 9

CZ OBSAH

BEZPEČNOSTNÍ OPATŘENÍ 1
SCHÉMA INSTALACE VNITŘNÍ A VENKOVNÍ JEDNOTKY 3
VNITŘNÍ JEDNOTKA 4
VENKOVNÍ JEDNOTKA 7
OSTATNÍ 9

HU TARTALOMJEGYZÉK

BIZTONSÁGI ELŐÍRÁSOK 1
BELTÉRI ÉS KÜLTÉRI EGYSSÉGEK ÜZEMBE HELYEZÉSE 3
BELTÉRI EGYSSÉG 4
KÜLTÉRI EGYSSÉG 7
EGYBEK 9

FR SOMMAIRE

MESURES DE SÉCURITÉ 1
PLAN D'INSTALLATION DES UNITÉS INTÉRIEURE ET EXTÉRIEURE 3
UNITÉ INTÉRIEURE 4
UNITÉ EXTÉRIEURE 7
AUTRES 9

PT ÍNDICE

PRECAUÇÕES RELATIVAS A SEGURANÇA 1
ESQUEMA DE INSTALAÇÃO DAS UNIDADES INTERIOR E EXTERIOR 3
UNIDADE INTERIOR 4
UNIDADE EXTERIOR 7
OUTROS 9

RU СОДЕРЖАНИЕ

МЕРЫ БЕЗОПАСНОСТИ 1
СХЕМА УСТАНОВКИ ВНУТРЕННЕГО И НАРУЖНОГО БЛОКОВ 3
ВНУТРЕННИЙ БЛОК 4
НАРУЖНЫЙ БЛОК 7
ДРУГИЕ 9

TR İÇİNDEKİLER

GÜVENLİK ÖNEMLERİ 1
İÇ VE DIŞ ÜNİTENİN MONTAJ ŞEMASI 3
İÇ ÜNİTE 4
DIŞ ÜNİTE 7
DİĞERLERİ 9

PRECAUTIONS FOR SAFETY

Be sure to read this installation manual carefully before installing.

Recommend to the owner to perform maintenance periodically when using over long periods of time.

Be sure to follow the precautions provided here to avoid safety risks. The symbols and their meanings are shown below.

DANGER : It indicates that incorrect use of this unit can result in a high possibility of severe injury (*1) or death.

WARNING : It indicates that incorrect use of this unit may cause severe injury or death.

CAUTION : It indicates that incorrect use of this unit may cause personal injury (*2), or property damage (*3).

*1 : A severe injury refers to blindness, injury, burns (hot or cold), electrical shock, bone fracture, or poisoning that leaves aftereffects and requires hospitalization or extended out-patient treatment.

*2 : Personal injury means a slight accident, burn, or electrical shock which does not require admission or repeated hospital treatment.

*3 : Property damage means greater damage which affects assets or resources.

For general public use

Power supply cord of parts of appliance for outdoor use shall be at least polychloroprene sheathed flexible cord (design H07RN-F) or cord designation 60245 IEC66 (1.5 mm² or more) (Shall be installed in accordance with national wiring regulations).

CAUTION

New refrigerant air conditioner installation

• **THIS AIR CONDITIONER USES THE NEW HFC REFRIGERANT (R410A), WHICH DOES NOT DESTROY THE OZONE LAYER.**

R410A refrigerant is apt to be affected by impurities such as water, oxidizing membranes, and oils because the pressure of R410A refrigerant is approx. 1.6 times of refrigerant R22. As well as the adoption of this new refrigerant, refrigerating machine oil has also been changed. Therefore, during installation work, be sure that water, dust, former refrigerant, or refrigerating machine oil does not enter the refrigeration cycle of a new-refrigerant air conditioner.

To avoid mixing refrigerant and refrigerating machine oil, the sizes of charging port connecting sections on the main unit are different from those for the conventional refrigerant, and different size tools are also required. For connecting pipes, use new and clean piping materials with highpressure withstand capabilities, designed for R410A only, and ensure that water or dust does not enter. Moreover, do not use any existing piping as its pressure withstand may be insufficient and may contain impurities.

DANGER

- FOR USE BY QUALIFIED PERSONS ONLY.
- MEANS FOR DISCONNECTION FROM THE SUPPLY HAVING A CONTACT SEPERATION OF AT LEAST 3 mm IN ALL POLES MUST BE INCORPORATED IN THE FIXED WIRING.
- TURN OFF MAIN POWER SUPPLY BEFORE ATTEMPTING ANY ELECTRICAL WORK. MAKE SURE ALL POWER SWITCHES ARE OFF. FAILURE TO DO SO MAY CAUSE ELECTRIC SHOCK.
- CONNECT THE CONNECTING CABLE CORRECTLY. IF THE CONNECTING CABLE IS CONNECTED WRONGLY, ELECTRIC PARTS MAY BE DAMAGED.
- CHECK THE EARTH WIRE THAT IT IS NOT BROKEN OR DISCONNECTED BEFORE INSTALLATION.
- DO NOT INSTALL NEAR CONCENTRATIONS OF COMBUSTIBLE GAS OR GAS VAPORS. FAILURE TO FOLLOW THIS INSTRUCTION CAN RESULT IN FIRE OR EXPLOSION.
- TO PREVENT OVERHEATING THE INDOOR UNIT AND CAUSING A FIRE HAZARD, PLACE THE UNIT WELL AWAY (MORE THAN 2 M) FROM HEAT SOURCES SUCH AS RADIATORS, HEATERS, FURNACE, STOVES, ETC.
- WHEN MOVING THE AIR CONDITIONER FOR INSTALLING IT IN ANOTHER PLACE AGAIN, BE VERY CAREFUL NOT TO GET THE SPECIFIED REFRIGERANT (R410A) WITH ANY OTHER GASEOUS BODY INTO THE REFRIGERATION CYCLE. IF AIR OR ANY OTHER GAS IS MIXED IN THE REFRIGERANT, THE GAS PRESSURE IN THE REFRIGERATION CYCLE BECOMES ABNORMALLY HIGH AND IT RESULTINGLY CAUSES BURST OF THE PIPE AND INJURIES ON PERSONS.
- IN THE EVENT THAT THE REFRIGERANT GAS LEAKS OUT OF THE PIPE DURING THE INSTALLATION WORK, IMMEDIATELY LET FRESH AIR INTO THE ROOM. IF THE REFRIGERANT GAS IS HEATED BY FIRE OR SOMETHING ELSE, IT CAUSES GENERATION OF POISONOUS GAS.
- WHEN INTALLING OR RE-INSTALLING THE AIR CONDITIONER, DO NOT INJECT AIR OR OTHER SUBSTANCES BESIDES THE DESIGNATED REFRIGERANT "R410A" INTO THE REFRIGERATING CYCLE. IF AIR OR OTHER SUBSTANCES ARE MIXED, AN ABNORMAL PRESSURE CAN OCCUR IN THE REFRIGERATING CYCLE, AND THIS CAN CAUSE AN INJURY DUE TO A PIPE RUPTURE.

WARNING

- Installation work must be requested from the supplying retail dealership or professional vendors. Self-installation may cause water leakage, electrical shock, or fire as a result of improper installation.
- Specified tools and pipe parts for model R410A are required, and installation work must be done in accordance with the manual. HFC type refrigerant R410A has 1.6 times more pressure than that of conventional refrigerant (R22). Use the specified pipe parts, and ensure correct installation, otherwise damage and/or injury may be caused. At the same time, water leakage, electrical shock, and fire may occur.
- Be sure to install the unit in a place which can sufficiently bear its weight. If the load bearing of the unit is not enough, or installation of the unit is improper, the unit may fall and result in injury.
- Electrical work must be performed by a qualified electrical engineer in accordance with the code governing such installation work, internal wiring regulations, and the manual. A dedicated circuit and the rated voltage must be used. Insufficient power supply or improper installation may cause electrical shock or fire.
- Use a cable tie to connect wires in the indoor/outdoor units. Midway connection, stranded wire, and single-wire connections are not allowed. Improper connection or fixing may cause a fire.
- Wiring between the indoor unit and outdoor units must be well shaped so that the cover can be firmly placed. Improper cover installation may cause increased heat, fire, or electrical shock at the terminal area.
- Be sure to use only approved accessories or the specified parts. Failure to do so may cause the unit to fall, water leakage, fire or electrical shock.
- After the installation work, ensure that there is no leakage of refrigerant gas. If the refrigerant gas leaks out of the pipe into the room and is heated by fire or something else from a fanheater, stove or gas range, it causes generation of poisonous gas.
- Make sure the equipment is properly earthed. Do not connect the earth wire to a gas pipe, water pipe, lightning conductor, or telephone earth wire. Improper earth work may be the cause of electrical shock.
- Do not install the unit where flammable gas may leak. If there is any gas leakage or accumulation around the unit, it can cause a fire.
- Do not select a location for installation where there may be excessive water or humidity, such as a bathroom. Deterioration of insulation may cause electrical shock or fire.
- Installation work must be performed following the instructions in this installation manual. Improper installation may cause water leakage, electrical shock or fire. Check the following items before operating the unit.
 - Be sure that the pipe connection is well placed and there are no leaks.
 - Check that the service valve is open. If the service valve is closed, it may cause overpressure and result in compressor damage. At the same time, if there is a leak in the connection part, it may cause air suction and overpressure, resulting burst or injury.
- In pump down operations, ensure to perform the following procedures.
 - Do not inject air into the refrigeration cycle.
 - Be sure to close both service valves and stop the compressor before removing the refrigerant pipe. If removing the refrigerant pipe while the compressor is operating with the service valves opened, it may cause to air absorbed and abnormal high pressure inside the refrigeration cycle and resulting burst or injury.
- Do not modify the power cable, connect the cable midway, or use a multiple outlet extension cable. Doing so may cause contact failure, insulation failure, or excess current, resulting in fire or electrical shock.
- If you detect any damage, do not install the unit. Contact your supplying dealer immediately.
- Never modify this unit by removing any of the safety guards or bypassing any of the safety interlock switches.

CAUTION

- Please read this installation manual carefully before installing the unit. It contains further important instructions for proper installation.
- Exposure of unit to water or other moisture before installation could result in electric shock. Do not store it in a wet basement or expose to rain or water.
- After unpacking the unit, examine it carefully for possible damage.
- Do not install in a place that can increase the vibration of the unit. Do not install in a place that can amplify the noise level of the unit or where noise and discharged air might disturb neighbors.
- This appliance must be connected to the main power supply by means of a circuit breaker depending on the place where the unit is installed. Failure to do so may cause electrical shock.
- Follow the instructions in this installation manual to arrange the drain pipe for proper drainage from the unit. Ensure that drained water is discharged. Improper drainage can result in water leakage, causing water damage to furniture.
- Tighten the flare nut with a torque wrench using the prescribed method. Do not apply excess torque. Otherwise, the nut may crack after a long period of usage and it may cause the leakage of refrigerant.
- Wear gloves (heavy gloves such as cotton gloves) for installation work. Failure to do so may cause personal injury when handling parts with sharp edges.
- Do not touch the air intake section or the aluminum fins of the outdoor unit. It may cause injury.
- Do not install the outdoor unit in a place which can be a nest for small animals. Small animals could enter and contact internal electrical parts, causing a failure or fire.
- Request the user to keep the place around the unit tidy and clean.
- Make sure to conduct a trial operation after the installation work, and explain how to use and maintain the unit to the customer in accordance with the manual. Ask the customer to keep the operation manual along with the installation manual.

REQUIREMENT OF REPORT TO THE LOCAL POWER SUPPLIER

Please make absolutely sure that the installation of this appliance is reported to the local power supplier before installation. If you experience any problems or if the installation is not accepted by the supplier, the service agency will take adequate countermeasures.

INSTALLATION DIAGRAM OF INDOOR AND OUTDOOR UNITS

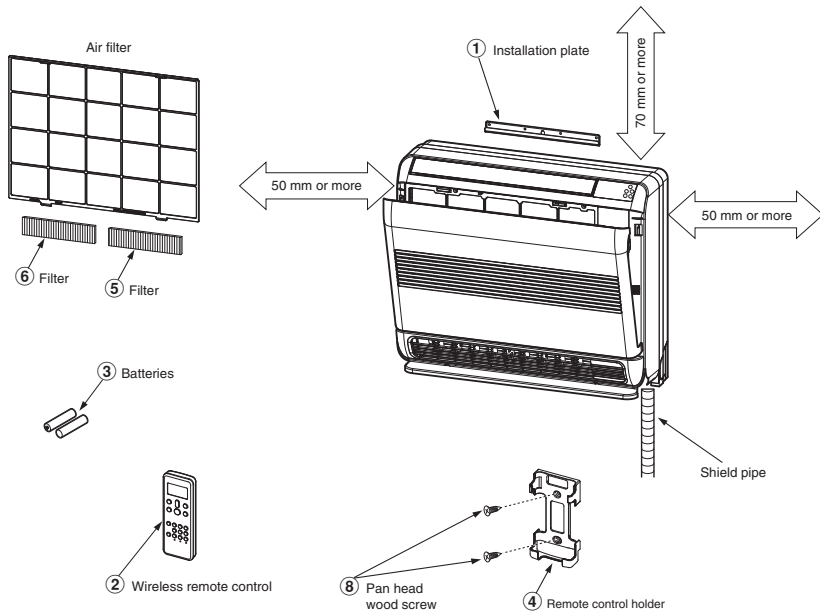

When installing the outdoor unit, leave open in at least two of direction (A), (B), (C) and (D) shown in the figure on the right.

Remark :

- Detail of accessory and installation parts can see in the accessory sheet.

CAUTION

Install in rooms that are 13 m³ or larger. If a leak of refrigerator gas occurs inside the room, an oxygen deficiency can occur.

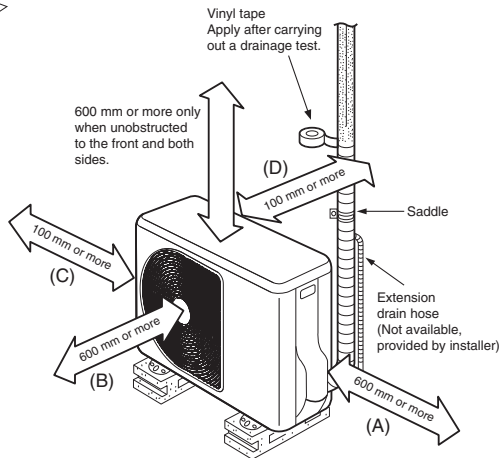

Do not allow the drain hose to get slack.



Make sure to run the drain hose sloped downward.

The auxiliary piping can be connected to the left, rear left, rear right, right, bottom right or bottom left.

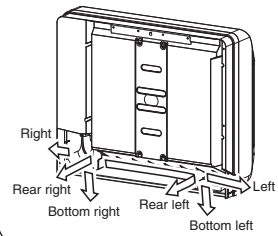

Insulate the refrigerant pipes separately with insulation, not together.

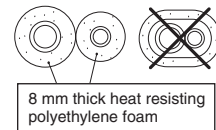

In case of right or left piping

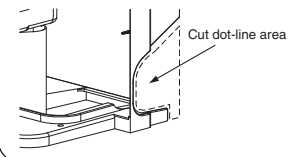

Optional Installation Parts

Part code	Parts name	Q'ty
(A)	Refrigerant piping Liquid side : $\varnothing 6.35$ mm Gas side : $\varnothing 9.52$ mm (RAS-(B) 10, 13UFV Series) : $\varnothing 12.7$ mm (RAS-(B) 18UFV Series)	One each
(B)	Pipe insulating material (polyethylene foam, 8 mm thick)	1
(C)	Putty, PVC tapes	One each

Fixing bolt arrangement of outdoor unit RAS-10, 13, 18SAV Series

- Secure the outdoor unit with fixing bolts and nuts if the unit is likely to be exposed to a strong wind.
- Use $\varnothing 8$ mm or $\varnothing 10$ mm anchor bolts and nuts.
- If it is necessary to drain the defrost water, attach drain nipple and cap water proof to the bottom plate of the outdoor unit before installing it.

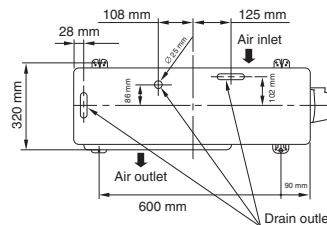

* Drain nipple and cap water proof are packed in outdoor unit.

※ When using a multi-system outdoor unit is used, refer to the installation manual provided with the model concerned.

INDOOR UNIT

Installation Place

- A place which provides the spaces around the indoor unit as shown in the diagram.
- A place where there are no obstacles near the air inlet and outlet.
- A place which allows easy installation of the piping to the outdoor unit.
- A place which allows the front panel to be opened.

CAUTION

- Direct sunlight to the indoor unit's wireless receiver should be avoided.
- The microprocessor in the indoor unit should not be too close to RF noise sources.
(For details, see the owner's manual)

Remote control

- A place where there are no obstacles such as a curtain that may block the signal from the remote control.
- Do not install the remote control in a place exposed to direct sunlight or close to a heating source such as a stove.
- Keep the remote control at least 1 m apart from the nearest TV set or stereo equipment (This is necessary to prevent image disturbances or noise interference).
- The location of the remote control should be determined as shown below.

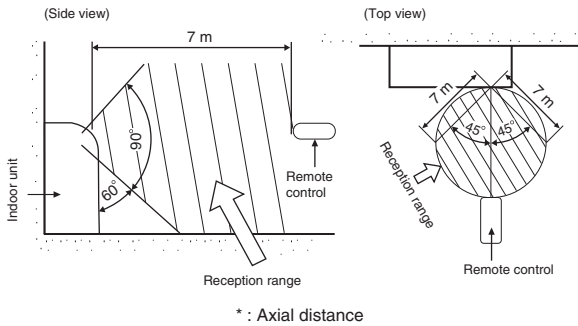

Cutting a Hole and Mounting Installation Plate

Cutting a hole

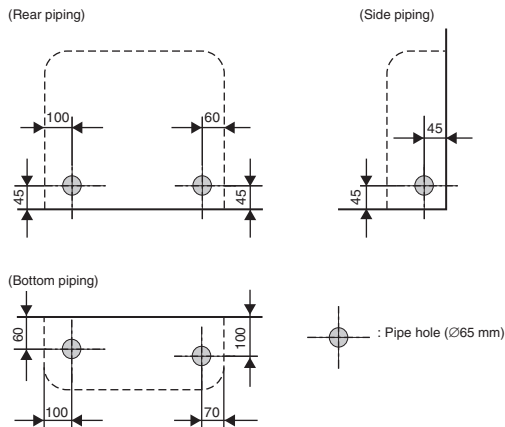

1. After determining the pipe hole position, drill the pipe hole (Ø65 mm) at a slight downward slant to the outdoor side.

NOTE

- When drilling a wall that contains a metal lath, wire lath or metal plate, be sure to use a pipe hole brim ring sold separately.

Mounting the installation plate and screw position

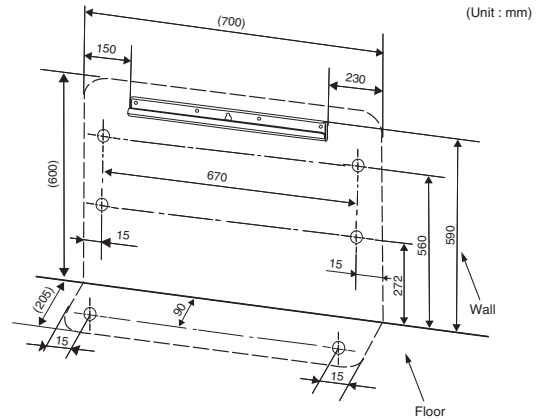

When the installation plate is directly mounted on the wall

1. Securely fit the installation plate onto the wall by screwing it in the upper and lower parts to hook up the indoor unit.
2. To mount the installation plate on a concrete wall with anchor bolts, use the anchor bolt holes as illustrated in the below figure.
3. Install the installation plate horizontally in the wall.

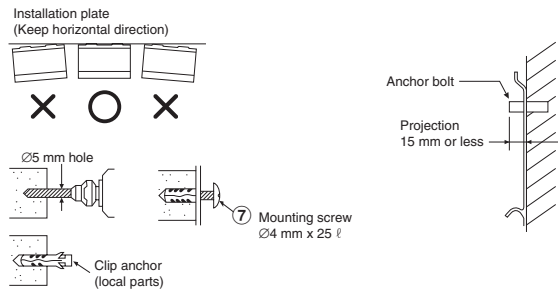

CAUTION

Failure to firmly install the unit may result in personal injury and property damage if the unit falls.

- In case of block, brick, concrete or similar type walls, make Ø5 mm holes in the wall.
- Insert clip anchors for appropriate mounting screws (7).

How to Install Indoor Unit

1. Remove the air inlet grille. Open the air inlet grille and remove the strap.
2. Remove the front panel (Remove the 4 screws).

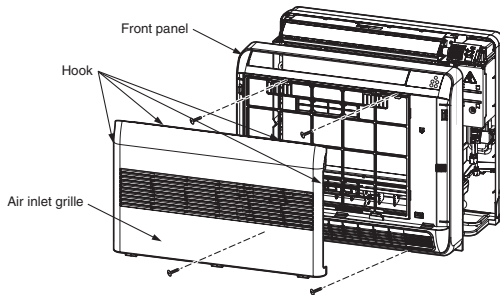

Layout of connection piping

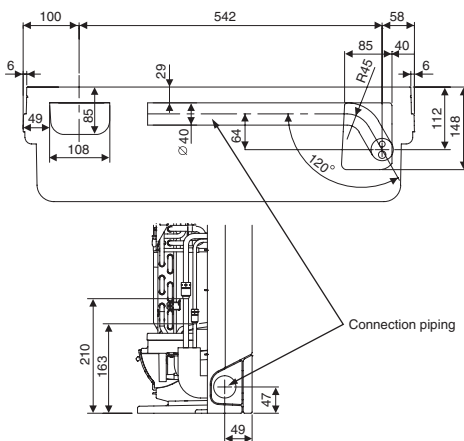

Treatment of piping connection

- 1) Check the flare nut connections for the gas leak with a gas leak detector or soap water.
- 2) To prevent gap in slit, fasten top and bottom with tape.
- 3) Slit is covered with tape.
- 4) Fasten with supplied Insulate sheet to prevent gap on the top of slit.

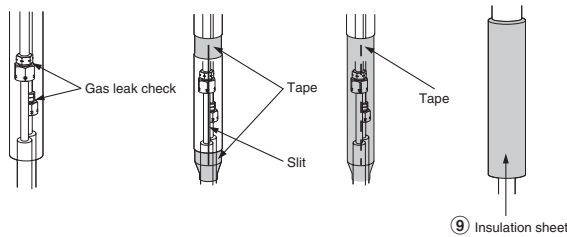

Drainage

1. Run the drain hose sloped downwards.

NOTE

- The hole should be made at a slight downward slant on the outdoor side.

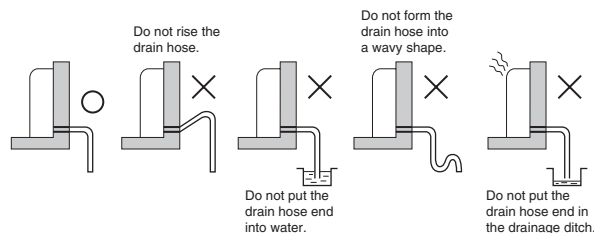

2. Put water in the drain pan and make sure that the water is drained out of doors.
3. When connecting extension drain hose, insulate the connecting part of extension drain hose with shield pipe.

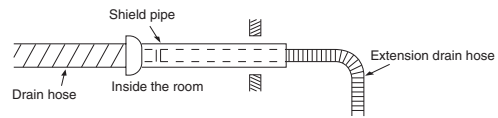

CAUTION

Arrange the drain pipe for proper drainage from the unit. Improper drainage can result in dew-dropping.

Wiring connection

Wiring of the connection cable is necessary to remove the front panel.

1. Remove the terminal cover and cord clamp.
2. Insert the connecting cable (according to the local rule) into the pipe hole on the wall.
3. Take out the connecting cable through the cable slot on the rear panel so that it protrudes about 50 cm from the front.
4. Insert the connecting cable fully into the terminal block and secure it tightly with screws.
5. Tightening torque : 1.2 N·m (0.12 kgf·m)
6. Secure the connecting cable with the cord clamp.
7. Fix the terminal cover, install the front panel and grille inlet.

CAUTION

- Be sure to refer to the wiring system diagram labeled inside the front panel.
- Check local electrical cords and also any specific wiring instructions or limitations.

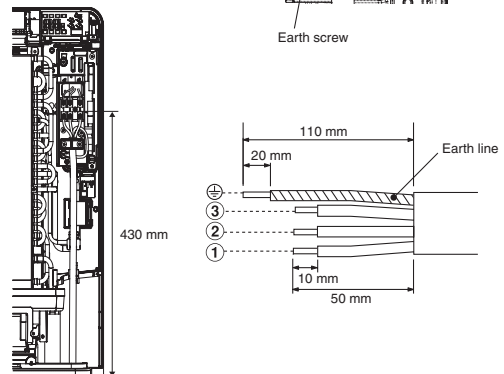
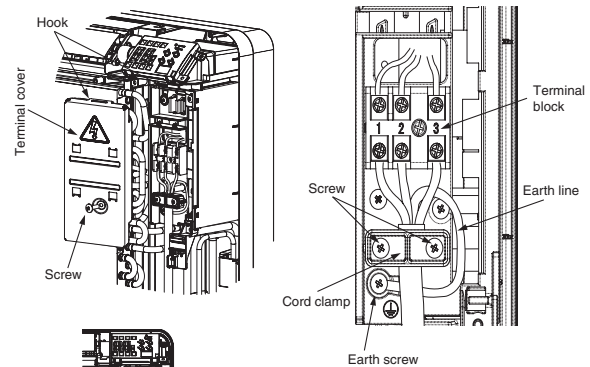

Stripping length of the connecting cable

NOTE

- Use stranded wire only.
- Wire type : H07RN-F or 60245 IEC66 (1.0 mm² or more)

Mounting directly on the floor.

- 1) Fix the leg of indoor unit on the floor with 2 mounting screws.
- 2) Fix the upper part of indoor unit on the wall with 4 mounting screws.

(Floor installation)

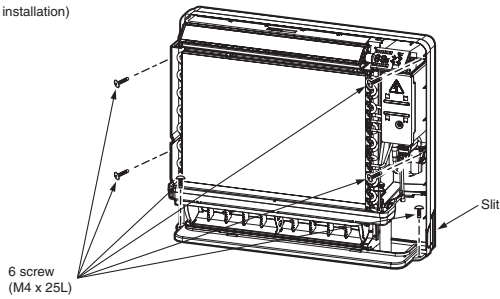

NOTE

- In case the plinth is fixed to the wall, please make sure to cut out the slit on the left and right side of the main part.

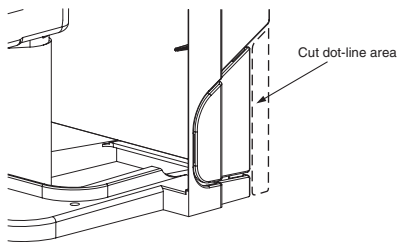

Installation on the wall

- 1) Fix the installation plate on the wall with 4 mounting screws.
- 2) Hook the indoor unit on the installation plate.
- 3) Fix the upper part of indoor unit on the wall with 4 mounting screws.

(Wall installation)

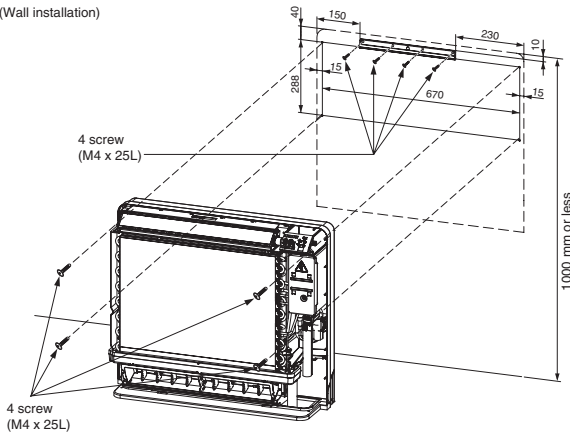

CAUTION

Make sure to fix it at a designated position with the screws.
Failure may result the damage of piping by the turning over of a set.

Concealed Installation

The special method to install the indoor unit bury in the wall is shown here. Please make sure to change to wall burying mode.

1. To switch to the wall burying mode
 - To switch to the wall burying mode, press and hold AIR OUTLET SELECT button for 20 seconds.
 - When the operation set up and 5 beep sounds. Then indication at Temperature indicator will light up for 5 seconds.
 - To cancel, press AIR OUTLET SELECT button for 20 seconds then, 5 beep sounds. Then indication at Temperature indicator will blinks for 5 seconds.
 - To prevent dewfall, above plate angle should be narrow.

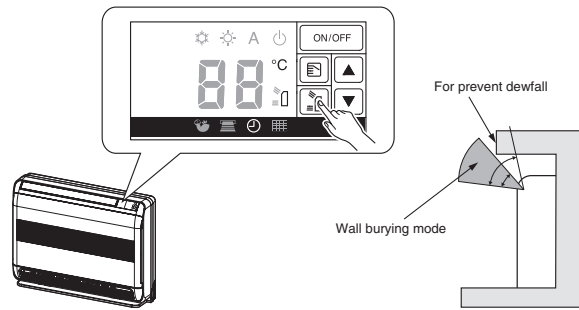

2. Wall hole size

Wall hole size should be enough to keep the distance with indoor unit as shown in the following figure.

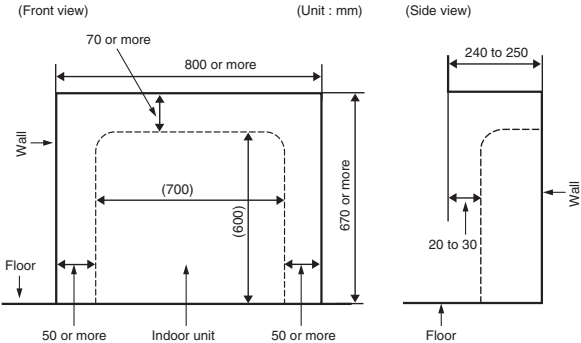

3. Installation using the supporting plate

- To install into the existing wall hole, if it is impossible to keep 20-30 mm of depth, use the supporting plate for securing the distance.
- Arrange the screw positions and supporting plate as shown in the figure.
- Be sure to switch to wall burying mode.

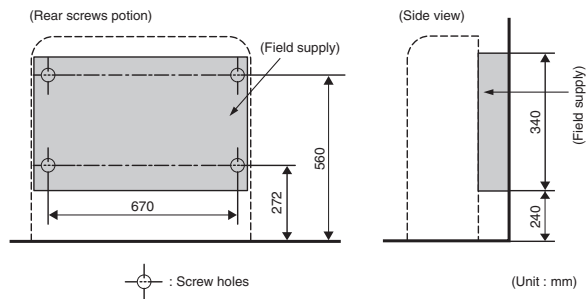

4. In case of lattice establishment

- Follow the following figure, make sure to keep enough distance between lattice, frame and wall.
- Be sure to switch to wall burying mode.
- The lattice should be make of wood.
- Between the air inlet and outlet, should be divided with partition board.
- Be sure to establish the open part for RECEIVER.
- The open part of lattice must be opens 70 % or more of the wall hole.
- The open part of lattice must be arranged uniformly.

(Top view)

(Unit : mm)

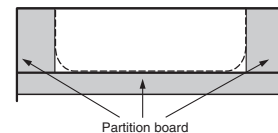

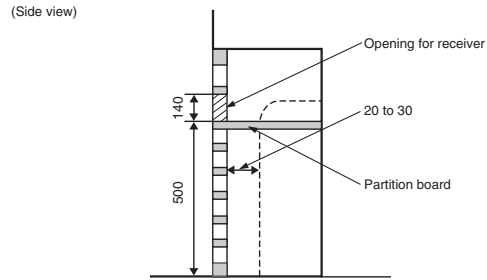
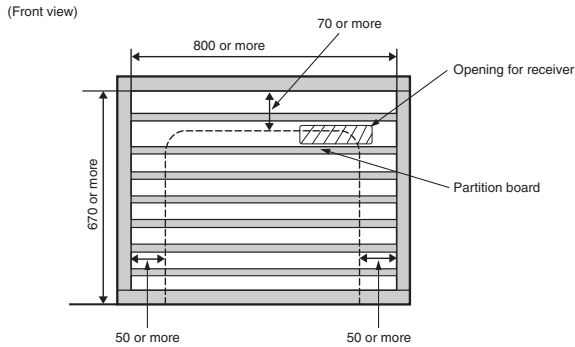

OUTDOOR UNIT

- When using a multi-system outdoor unit refer to the installation manual provided with the model concerned.

Installation Place

- A place which provides enough spaces around the outdoor unit as shown in the diagram.
- A place which can bear the weight of the outdoor unit and does not allow an increase in noise level and vibration.
- A place where the operation noise and discharged air do not disturb your neighbors.
- A place which is not exposed to a strong wind.
- A place free of a leakage of combustible gases.
- A place which does not block a passage.
- When the outdoor unit is to be installed in an elevated position, be sure to secure its feet.
- This air conditioner accepts a connection piping length from 2 m to 20 m.
- There is no need to add refrigerant as long as the length of the connection piping is 15 m or less.
- You will need to add 20 g of refrigerant per meter of added connection piping for installation requiring connection piping to be between 16 m to 20 m.
- An allowable height level is up to 10 m.
- A place where the drain water does not cause any problems.

Precautions about Installation in Regions with Snowfall and Cold Temperatures

- Do not use the supplied drain nipple for draining water. Drain the water from all the drain holes directly.
- To protect the outdoor unit from snow accumulation, install a holding frame, and attach a snow protection hood and plate.
- Do not use a double-stacked design.

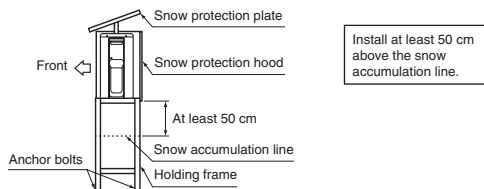

CAUTION

- Install the outdoor unit in a location where there are no obstructions near its air intake or air outlet.
- When the outdoor unit is installed in a place that is always exposed to strong winds like on the coast or on a high story of a building, secure the normal fan operation using a duct or a wind shield.
- Especially in windy areas, install the unit to prevent the admission of wind.
- Installation in the following places may result in trouble. Do not install the unit in such places.
 - A place full of machine oil.
 - A saline-place such as the coast.
 - A place full of sulfide gas.
 - A place where high-frequency waves are likely to be generated, such as from audio equipment, welders, and medical equipment.

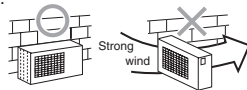

Draining off the Water from the Outdoor Unit

- If it is necessary to drain off the water from the outdoor unit, install two water-proofing rubber caps and a drain nipple.

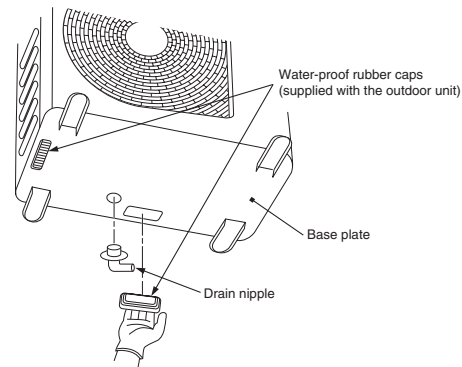

Refrigerant Piping Connection

Flaring

- Cut the pipe with a pipe cutter.
- Deburr the inside of the pipe at its end. Take steps to ensure that the removed burrs will not enter the pipe.
- Remove the flare nuts provided with the indoor and outdoor units, and insert them into the pipe.
- Flare the pipe. The projection margin of the pipe must be checked.
- Check that the flare has the appropriate shape.

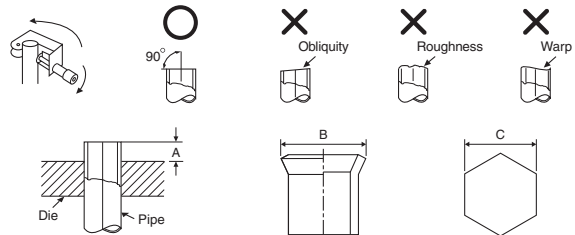

Pipe		A		B		Flare Nut	
Outside diameter	Thickness	Rigid (clutch type) R410A tool	Imperial (wing nut type) R410A tool	C		Tighten torque	
mm	mm	mm	mm	mm	mm	N-m	kgf-m
6.35	0.8	0 to 0.5	1.5 to 2.0	9.1	17	14 to 18	1.4 to 1.8
9.52	0.8	0 to 0.5	1.5 to 2.0	13.2	22	33 to 42	3.3 to 4.2
12.7	0.8	0 to 0.5	2.0 to 2.5	16.6	26	50 to 62	5.0 to 6.2

• **Tightening torque for connection of flare pipe**

The pressure of R410A is higher than R22 (Approx. 1.6 times). Therefore securely tighten the flare pipes which connect the outdoor unit and the indoor unit with the specified tightening torque using a torque wrench. If any flare pipe is incorrectly connected, it may cause not only a gas leakage but also trouble in the refrigeration cycle.

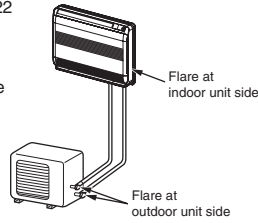

Gas side (Ø12.70 mm)	50 to 62 N·m (5.0 to 6.2 kgf·m)
Gas side (Ø9.52 mm)	33 to 42 N·m (3.3 to 4.2 kgf·m)
Liquid side (Ø6.35 mm)	14 to 18 N·m (1.4 to 1.8 kgf·m)
Service port	14 to 18 N·m (1.4 to 1.8 kgf·m)

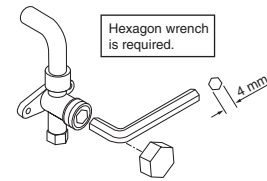

Evacuating

After the piping has been connected to the indoor unit, you can perform vacuuming together at once.

VACUUMING

Evacuate the air in the connecting pipes and in the indoor unit using a vacuum pump. Do not use the refrigerant in the outdoor unit. For details, see the manual of the vacuum pump.

Using a vacuum pump

Be sure to use a vacuum pump with counter-flow prevention function so that inside oil of the pump does not flow backward into pipes of the air conditioner when the pump stops. (If oil inside of the vacuum pump enters the air conditioner, which use R410A, refrigeration cycle trouble may happen.)

1. Connect the charge hose from the manifold valve to the service port of the packed valve at gas side.
2. Connect the charge hose to the port of the vacuum pump.
3. Open fully the low pressure side handle of the gauge manifold valve.
4. Operate the vacuum pump to start evacuating. Perform evacuating for about 15 minutes if the piping length is 20 meters (15 minutes for 20 meters) (assuming a pump capacity of 27 liters per minute). Then confirm that the compound pressure gauge reading is -101 kPa (-76 cmHg).
5. Close the low pressure side valve handle of the gauge manifold valve.
6. Open fully the valve stem of the packed valves (both gas and liquid sides).
7. Remove the charging hose from the service port.
8. Securely tighten the caps on the packed valves.

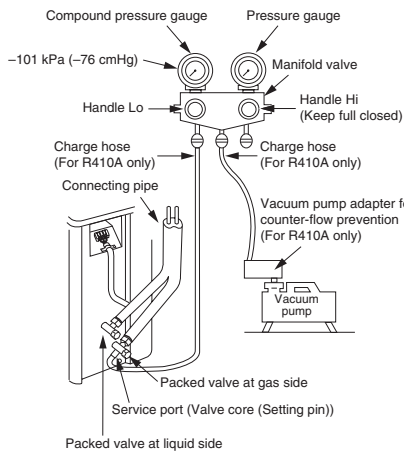

CAUTION

• **KEEP IMPORTANT 5 POINTS FOR PIPING WORK.**

- (1) Take away dust and moisture (inside of the connecting pipes).
- (2) Tighten the connections (between pipes and unit).
- (3) Evacuate the air in the connecting pipes using a VACUUM PUMP.
- (4) Check gas leak (connected points).
- (5) Be sure to fully open the packed valves before operation.

Packed valve handling precautions

- Open the valve stem until it touches the stopper. Once it is in contact with the stopper, refrain from applying any more force than is necessary.
- Securely tighten the valve stem cap with torque in the following table:

Wiring Connection

1. Remove the valve cover, the electric parts cover and the cord clamp from the outdoor unit.
2. Connect the connecting cable to the terminal as identified by the matching numbers on the terminal block of indoor and outdoor unit.
3. Insert the power cord and the connecting cable fully into the terminal block and secure it tightly with screws.
4. Use vinyl tape, etc. to insulate the cords which are not going to be used. Locate them so that they do not touch any electrical or metal parts.
5. Secure the power cord and the connecting cable with the cord clamp.
6. Attach the electric parts cover and the valve cover on the outdoor unit.

EN

Electrical Work

1. The supply voltage must be the same as the rated voltage of the air conditioner.
2. Prepare the power source for exclusive use with the air conditioner.

Model	RAS-(B)10UFV series	RAS-(B)13UFV series	RAS-(B)18UFV series
Power source	220-240V ~ 50Hz 220-230V ~ 60Hz	220-240V ~ 50Hz 220-230V ~ 60Hz	220-240V ~ 50Hz 220-230V ~ 60Hz
Maximum running current	8.5A	11.0A	12.0A
Plug socket & fuse rating	16A		
Power cord	H07RN-F or 60245 IEC66 (1.5 mm ² or more)		
Connecting cable	H07RN-F or 60245 IEC66 (1.0 mm ² or more)		

※ When using a multi-system outdoor unit is used, refer to the installation manual provided with the model concerned.

Stripping length of the connecting cable

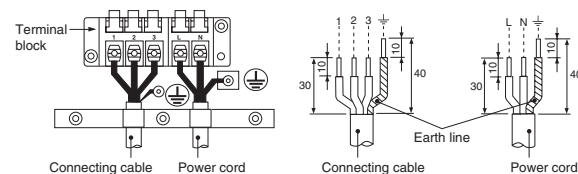

RAS-10SAVR-A, RAS-18SAV-E

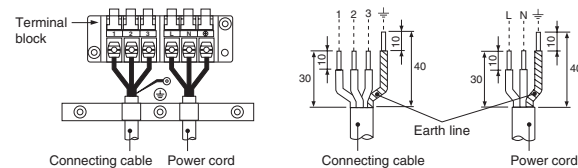

CAUTION

- Wrong wiring connection may cause some electrical parts burn out.
- Be sure to comply with local rule on running the wire from indoor unit to outdoor unit (size of wire and wiring method, etc.).
- Every wire must be connected firmly.
- If incorrect or incomplete wiring is carried out, it will cause an ignition or smoke.
- Prepare the power supply for exclusive use with the air conditioner.
- This product can be connected to the mains.
Connection to fixed wiring : A switch which disconnects all poles and has a contact separation of at least 3 mm must be incorporated in the fixed wiring.

OTHERS

Gas Leak Test

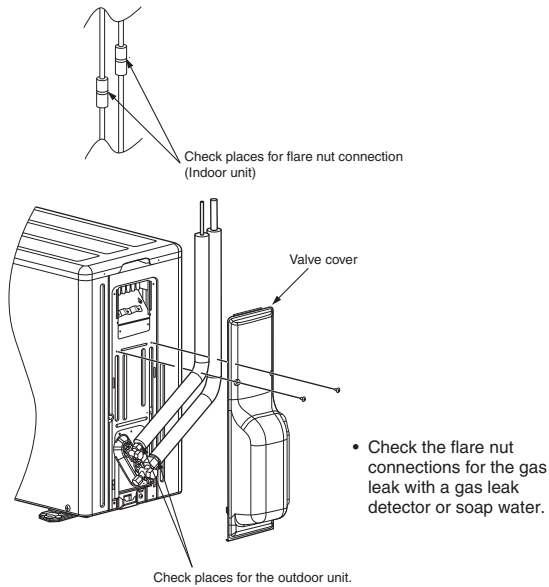

Setting of Remote Control Selector Switch

When two indoor units are installed in the separated rooms, it is not necessary to change the selector switches.

Remote control selector switch

- When two indoor units are installed in the same room or adjacent two rooms, if operating a unit, two units may receive the remote control signal simultaneously and operate. In this case, the operation can be preserved by setting either one indoor unit or remote control to B setting (Both are set to A setting in factory shipment).
- The remote control signal is not received when the settings of indoor unit and remote control are different.
- There is no relation between A setting/B setting and A room/B room when connecting the piping and cables.

Remote Control A-B Selection

To separate using of remote control for each indoor unit in case of 2 air conditioners are installed nearby.

Remote Control B Setup.

1. Push and hold **CHK** button on the Remote Control by the tip of the pencil. "00" will be shown on the display.
2. Press **MODE** during pushing **CHK**. "B" will show on the display and "00" will disappear and the air conditioner will turn OFF. The Remote Control B is memorized.

Note : 1. Repeat above step to reset Remote Control to be A.
2. Remote Control A has not "A" display.
3. Default setting of Remote Control from factory is A.

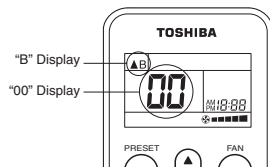

Unit B setup.

Press and hold **MODE** button for more than 20 seconds.
When A setup changed to B setup : 5 beeps will sound and operation lamp blinks for 5 seconds.
When B setup changed to A setup : 5 beep will sound.

Test Operation

To switch the **TEST RUN (COOL)** mode, press **OPERATION** button for 10 seconds (The beeper will make a short beep).

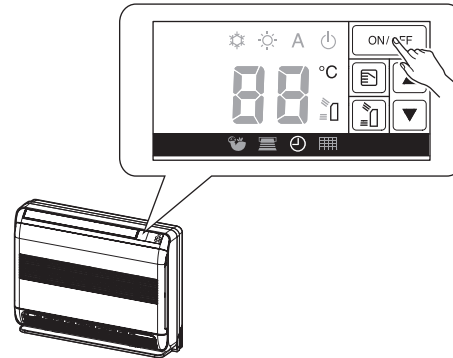

Auto Restart Setting

This product is designed so that, after a power failure, it can restart automatically in the same operating mode as before the power failure.

Information

The product are shipped with Auto Restart function in the off position. Turn it on as required.

How to set the Auto Restart

1. Press and hold **OPERATION** button on the indoor unit for 3 seconds to set the operation (3 beep sound and **OPERATION** lamp blink 5 time/sec for 5 seconds).
2. Press and hold **OPERATION** button on the indoor unit for 3 seconds to cancel the operation (3 beep sound but **OPERATION** lamp does not blink).
 - In case of ON timer or OFF timer are set, it dose not activate.