

Toshiba Air Conditioning - RAS Data Sheet

RAS-13G2KVP-E Daiseikai High-Wall Inverter

Features

- Class-leading energy saving
- Extremely low sound levels
- Plasma air purifier
- Power change button to reduce power consumption by up to 50%
- Self-cleaning function



Technical Data

Model reference indoor unit		RAS-13G2KVP-E
Nominal cooling	kW	3.50
Nominal heating	kW	4.00
UK cooling	kW	3.42
UK sensible cooling	kW	2.89
UK heating	kW	2.56
Annual power consumption	kWh	410
Air flow (cool/heat - high)	m ³ /h	672/726
Sound pressure (cool/heat - high)	dB(A)	43/44
Dimensions (H x W x D)	mm	293 x 831 x 270
Unit weight	kg	14
Model reference outdoor unit		RAS-13G2AVP-E
System starting current	A	1
Suggested fuse size	A	10
Power supply	V-ph-Hz	220/240-1-50
Interconnecting cable		3-core + earth
Sound pressure (cool/heat)	dB(A)	48/49
Air flow (cool/heat - high)	m ³ /h	2160/2160
Dimensions (H x W x D)	mm	630 x 799 x 299
Unit weight	kg	42
Pipe sizes (liquid-suction)	inch	1/4-3/8
Maximum pipe length/height difference	m	25/10
Pre-charge pipe length	m	15
Additional refrigerant - factory charge	g/m - kg	20 - 1.05
EER/COP		4.27/5.00
SEER/SCOP		8.90/5.10

Dimensional Drawings

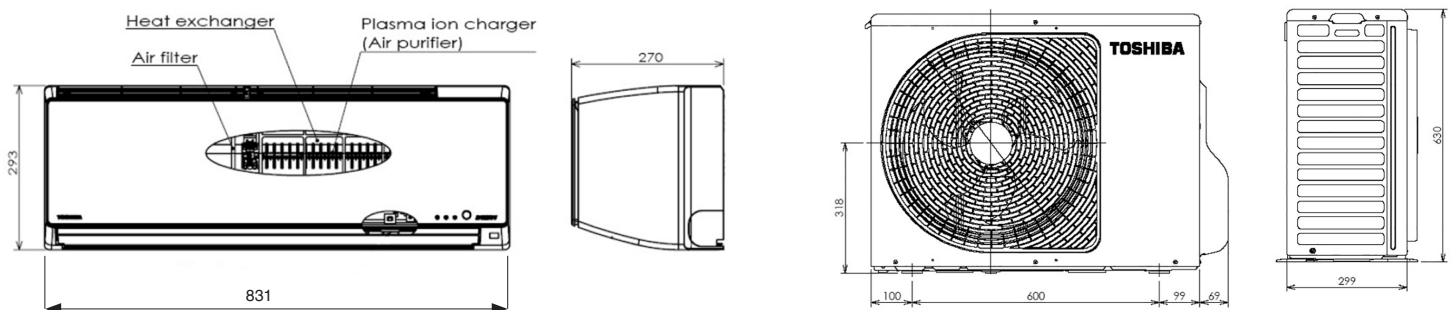

Cool Designs Ltd

Raising the Standards in Air Conditioning Distribution

www.cdlweb.info

