



CIAT - COADIS LINE 900 Cassette fan coil unit

COADIS LINE 900 Cassette fan coil unit

Features

- Suction/discharge through 180° or 360° FLEXIWAY grille.
- Installation in reduced ceilings with modern styling.
- Air supply with Coanda effect for guaranteed comfort.
- Epure filter for excellent air quality.
- Manufactured according to eco-concept, 87% recyclable.
- Quiet, standard or energy-efficient HEE motor.



Technical Data

For cooling or heating (2-pipe)						
Unit		Cooling	Heating	Dimensions - W x D x H	Weight	Part Number
Coadis Line	Motor	W	W	mm	kg	
922	Standard	6100	7730	900 x 900 x 357	45.0	7344009
932	Standard	7640	9000	900 x 900 x 357	50.0	7344010
922	HEE	6060	7770	900 x 900 x 357	45.0	7344015
932	HEE	7600	9040	900 x 900 x 357	50.0	7344016
932SP	HEE	9350	11200	900 x 900 x 357	50.0	7351393
For cooling or heating (4-pipe)						
Unit		Cooling	Heating	Dimensions - W x D x H	Weight	Part Number
Coadis Line	Motor	W	W	mm	kg	
924	Standard	6100	4100	900 x 900 x 357	45.0	7344011
934	Standard	7640	5070	900 x 900 x 357	50.0	7344012
924	HEE	6060	4110	900 x 900 x 357	45.0	7344017
934	HEE	7600	5090	900 x 900 x 357	50.0	7344018
934SP	HEE	9350	5720	900 x 900 x 357	50.0	7351394
4-way grille						
Description						Part Number
360° suction/discharge grille with Epure filter						7335537

All units are supplied with an Epure air filter as standard. These Epure filters need to be replaced periodically. Replacement filters can be found at the back of this price list.

The above capabilities are based on Eurovent conditions. For 2-pipe unit, cooling with an air inlet temperature of 27°C/WB 19°C and a water range of 7-12°C, heating with an air inlet temperature of 20°C/50% RH and a water inlet of 50°C at high fan speed. For 4-pipe unit, cooling with an air inlet temperature of 27°C/WB 19°C and a water range of 7-12°C, heating with an air inlet temperature of 20°C/50% RH and a water range of 70-60°C at high fan speed. Alternative 2-pipe units are available with electric heating. CIAT participates in the Eurovent certification program. For a list of products and certified characteristics, please refer to www.eurovent-certification.com.

Dimensional Drawings

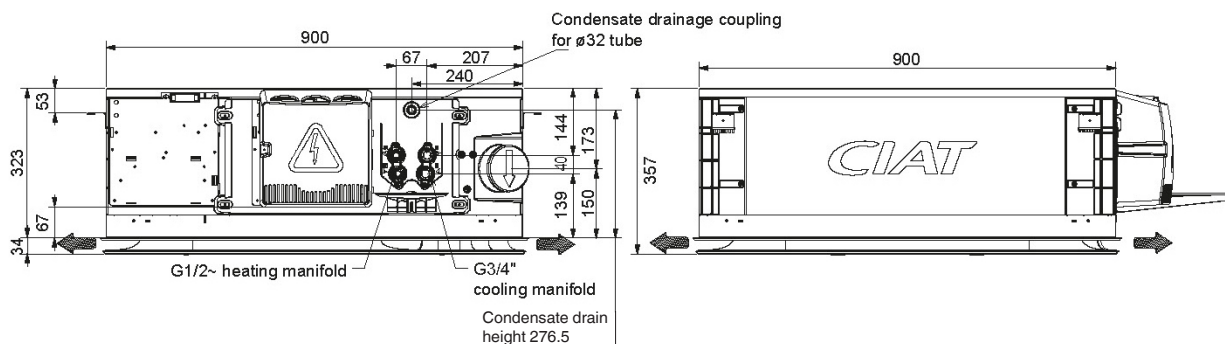

Cool Designs Ltd

Raising the Standards in Air Conditioning Distribution

www.cdlweb.info





CIAT - COADIS LINE 900 Cassette fan coil unit

COADIS LINE 900
Cassette fan coil unit



Available unit options

Description	Part Number
4-way water control valve* (2-pipe)	E037567
2-way water control valve* (2-pipe)	E037605
2-piece 4-way water control valve* (4-pipe)	E037583
2-piece 2-way water control valve* (4-pipe)	E037621
Condensate pump for 900 included	7301623
Wall-mounted thermostat RTR 7011/RTR 7203*	5201018/5201021
Set of mounting rubbers (per unit)*	Set = 4 x 0219453

* Options supplied separately. All water control valves, equipped with 230 V/1 ph/50 Hz thermal actuator (open/closed). Other arrangements on request.

Cool Designs Ltd

Raising the Standards in Air Conditioning Distribution

www.cdlweb.info

