



CIAT - AQUACIAT

Air-cooled heat pumps

AQUACIAT

Air-cooled heat pumps

Features

- Screwed connection sleeves as standard.
- Anti-vibration mounts as standard.
- Brazed heat exchanger to offer high efficiency and reduced refrigerant.
- Connect touch controller.
- Ice prevention frame coil heater.



Technical Data

AQUACIAT heat pump model		ILD0150A	ILD0180A	ILD0200A	ILD0240A	ILD0260A	ILD0300A
Nominal cooling capacity*	kW	38	43	50	59	64	74
EER/ESEER	kW/kW	2.84/3.80	2.70/3.77	2.65/3.81	2.77/3.61	2.70/3.61	2.58/3.57
Eurovent class	C1	C	C	D	C	C	D
Nominal heating capacity**	kW	42	47	53	61	70	78
COP/SCOP	kW/kW	3.08/3.07	3.05/3.10	3.03/3.21	3.03/3.07	3.06/3.10	2.87/2.96
Eurovent class	H1	B	B	B	B	B	C
Sound power***/Sound pressure at 10 m****	dB(A)	80/49	81/49	81/49	86/55	87/55	87/55
Sound power extra low noise option***	dB(A)	79	80	80	80	80	80
Sound pressure at 10 m extra low noise option†	dB(A)	48	48	48	48	48	48
Width x length	mm	2109 x 1090	2109 x 1090	2109 x 1090	2109 x 1090	2109 x 1090	2109 x 1090
Height (with buffer tank)	mm	1440 (2040)	1440 (2040)	1440 (2040)	1440 (2040)	1440 (2040)	1440 (2040)
Weight - standard unit	kg	497	506	543	549	559	564
Compressors	Scroll	2	2	2	2	2	2
Minimum output	%	50	50	50	50	50	50
Maximum total air flow	l/s	3692	3690	3910	5285	5284	5282
Part Number (heat pump only)		7490822	7490823	7490824	7490825	7490826	7490827
Part Number (heat pump with AquaPack)†		7490822-AP	7490823-AP	7490824-AP	7490825-AP	7490826-AP	7490827-AP

AQUACIAT heat pump model		ILD0302A	ILD0360A	ILD0390A	ILD0450A	ILD0520A	ILD0600A
Nominal cooling capacity*	kW	78	86	96	113	132	149
EER/ESEER	kW/kW	2.79/3.84	2.70/3.77	2.7/3.88	2.69/4.04	2.77/3.75	2.58/3.67
Eurovent class	C1	C	C	C	D	C	D
Nominal heating capacity**	kW	80	93	101	117	138	158
COP/SCOP	kW/kW	3.08/3.14	3.02/3.17	3.09/3.23	3.06/3.23	3.07/3.14	2.97/3.13
Eurovent class	H1	B	B	B	B	B	C
Sound power***/Sound pressure at 10 m****	dB(A)	84/52	84/52	84/52	84/52	90/58	90/58
Sound power extra low noise option***	dB(A)	83	83	83	83	83	83
Sound pressure at 10 m extra low noise option****	dB(A)	52	51	51	51	51	51
Width x length	mm	2123 x 2270	2123 x 2270	2123 x 2270	2123 x 2270	2123 x 2270	2123 x 2270
Height (with buffer tank)	mm	1440 (2040)	1440 (2040)	1440 (2040)	1440 (2040)	1440 (2040)	1440 (2040)
Weight - standard unit	kg	777	896	905	979	1053	1057
Compressors	Scroll	3	3	3	3	2 + 2	2 + 2
Minimum output	%	33	33	33	33	25	25
Maximum total air flow	l/s	7770	7380	7376	7818	10568	10568
Part Number (heat pump only)		7491009	7490828	7490829	7490830	7490831	7490832
Part Number (heat pump with AquaPack)†		7491009-AP	7490828-AP	7490829-AP	7490830-AP	7490831-AP	7490832-AP

* Cooling mode conditions: water inlet/outlet temperature 12°C/7°C, ambient 35°C.

** Heating mode conditions: water inlet/outlet temperature 30°C/35°C, ambient 7°C/6°C.

*** In dB ref = 10⁻¹² W, 'A' weighted. Measured in accordance with ISO 9614-1.

**** In dB ref 20 uPa, 'A' weighted. For information, calculated from the sound power level Lw(A). Declared dual number noise emission values in accordance with ISO 4871 (with an associated uncertainty of ±3 dB(A). Values are guidelines only. Refer to the unit name plate.

† AquaPack includes: hydronic module 116, expansion tank 293, water buffer tank module 307, exchanger water filter 310A).

Cool Designs Ltd

Raising the Standards in Air Conditioning Distribution

www.cdlweb.info





CIAT - AQUACIAT

Air-cooled heat pumps

AQUACIAT

Air-cooled heat pumps



Accessories

Description	Part Number
Pre-treatment corrosion protection	3A
Medium brine application	5B
Low brine application	6B
Extra fan (180 to 240 mmCE available)*	12_1
Extra low noise (1 to 6 dB(A) depending on model)*	15LS_1
Soft Start	25
All year -20°C operation*	28_1
Water exchanger frost protection*	42
Exchanger and hydraulic frost protection	42B
Master/slave operation	58
Hydraulic module (fixed-speed single pump) HP	116R
Hydraulic module (fixed-speed dual pump) HP	116S
Hydraulic module (fixed-speed single pump) LP	116T
Hydraulic module (fixed-speed dual pump) LP	116U
Hydraulic module (variable-speed single pump) HP	116V
Hydraulic module (variable-speed dual pump) HP	116W
BACnet over IP	149
External boiler management	156A
Electric heater management	156B
Reinforced ECM filtration for fan VFD	282A
Reinforced ECM filtration for pump VFD	282B
Expansion tank	293
Water buffer tank module	307
Exchanger flexible sleeve connections	309A
Exchanger water filter	310A
Set point adjustment by 4-20 mA signal	311

* Not available with some options.

Dimensional Drawings

AQUACIAT ILD150A - ILD300A

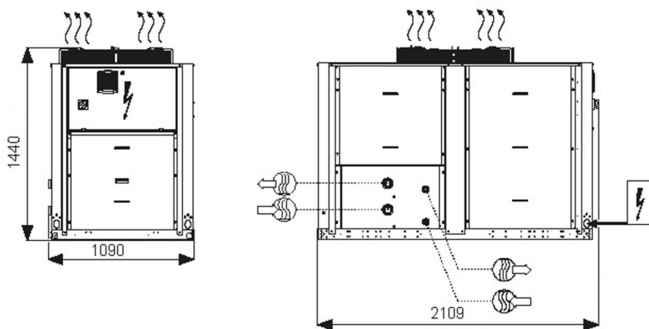

AQUACIAT ILD302A - ILD600A

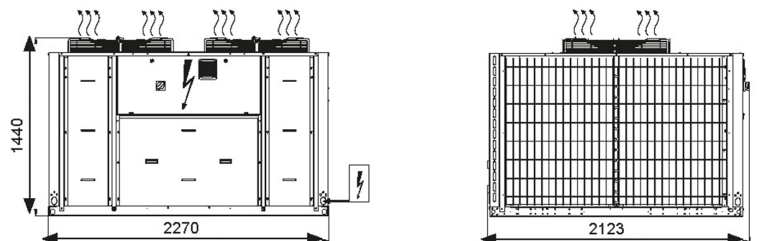

Cool Designs Ltd

Raising the Standards in Air Conditioning Distribution

www.cdlweb.info

